



Skill India
वीरम मरुत - कुरुम मरुत



भारत सरकार
GOVERNMENT OF INDIA
MINISTRY OF SKILL DEVELOPMENT
& ENTREPRENEURSHIP



N.S.D.C.
National
Skill Development
Corporation

Transforming the skill landscape



Facilitator Guide



Sector
Apparel / Made-Up's /
Home Furnishing

Sub-Sector
Apparel

Occupation
Self Employed Tailor

Reference ID: AMH/Q1947, Version 1.0
NSQF Level: 4

Self Employed Tailor

Published by



RACHNA SAGAR PVT. LTD.

4583/15, Daryaganj, New Delhi, 110002, PO Box 7226

Phone: 011 - 4358 5858, 2328 5568 Fax 011 - 2324 3519, 4311 5858

Email: info@rachnasagar.in

All Rights Reserved,
First Edition, March 2016
ISBN 978-1-111-22222-45-7
Printed in India

Copyright © 2017



Apparel Made-ups & Home Furnishing Sector Skill Council

Indian Buildings Congress, 1st Floor, Sector-6, R K Puram

Kama Koti marg, New Delhi - 110022

E-mail : info@sscamh.com

Website : www.sscamh.com

Disclaimer

The information contained herein has been obtained from sources reliable to AMHSSC. AMHSSC disclaims all warranties to the accuracy, completeness or adequacy of such information. AMHSSC shall have no liability for errors, omissions, or inadequacies, in the information contained herein, or for interpretations thereof. Every effort has been made to trace the owners of the copyright material included in the book. The publishers would be grateful for any omissions brought to their notice for acknowledgements in future editions of the book. No entity in AMHSSC Council shall be responsible for any loss whatsoever, sustained by any person who relies on this material. The material in this publication is copyrighted. No parts of this publication may be reproduced, stored or distributed in any form or by any means either on paper or electronic media, unless authorized by the AMHSSC.





Shri Narendra Modi
Prime Minister of India

“ Skilling is building a better India. If we have to move India towards development then Skill Development should be our mission. ”



Acknowledgement

We are thankful to all organisations and individuals who have helped us in preparation of this Facilitator Guide.

We are especially thankful to Dr. S.K Sharma (M/S The Assessors Guild) for their unequivocal support in the entire process.

We are also thankful to M/S Poppys Knitwears Private Limited, M/S Kanhaiyalal Kalyanmal, M/S Nirvana, M/S Poddar International, M/S Paper Moon , M/S Ocean Exim India Pvt. Ltd. and Savvy Corporation, for their kind support in development of this guide.

About this Guide

This Facilitator Guide is designed to enable training for the specific Qualification Pack (QP). Each National Occupational (NOS) is covered across Unit/s.

The Trainers will be able to get a clear insight regarding the purpose of the program and will be able to give the participants proper training regarding stitching or sewing fabrics, fur and synthetic materials.

The various requirements of team working, detecting quality defects, maintaining healthy workplace and so on can be provided by the trainers to the participants.

The rules and regulations for proving the training have been clearly given in the book and they should be holistically followed by the trainers to meet the purpose behind the framing of this course.

Key Learning Objectives for the specific NOS mark the beginning of the Unit/s for that NOS.

- Drafting and cutting the fabric
- Carry out the process of sewing for dress materials and common household items of textiles
- Carry out inspections and alterations to adjust corrections for fittings
- Maintain health, safety and security in the tailoring shop
- Maintain work area, tools and machines
- Comply with industry, regulatory and organizational requirements

The symbols used in this book are described below.

Symbols Used

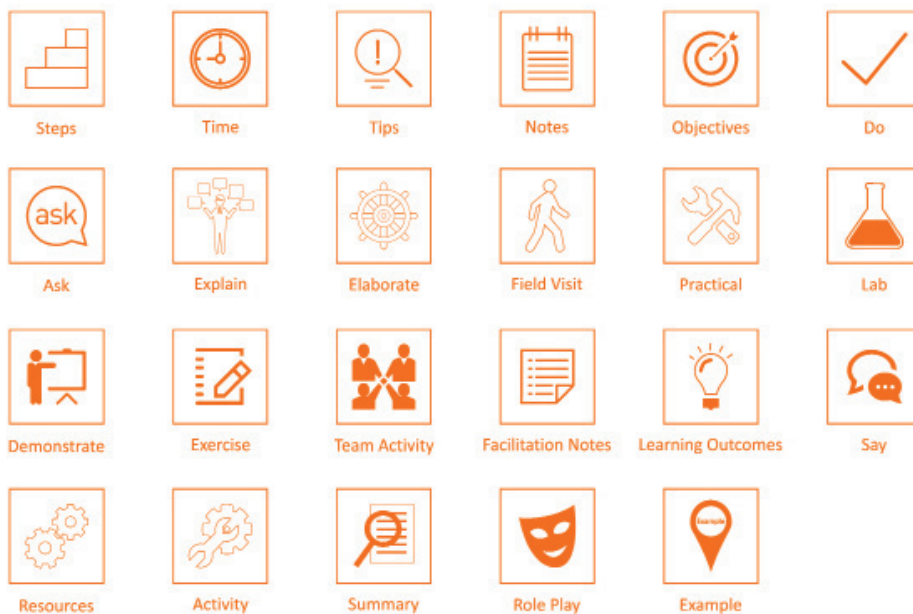

Table of Content

S. No.	Modules and Units	Page No.
1.	Introduction and Orientation	1
	Unit 1.1 - Apparel Industry	3
	Unit 1.2 - Role and Responsibilities of a Tailor	5
2.	Drafting and cutting the fabric (AMH/N1947)	7
	Unit 2.1 - Tools and Equipment Required for Tailoring	9
	Unit 2.2 - Types of Fabric	12
	Unit 2.3 - Trims and Accessories	15
	Unit 2.4 - Size Chart	18
	Unit 2.5 - Taking Measurements	22
	Unit 2.6 - Drafting and Cutting	26
	Unit 2.7 - Types of Fabric Defects	31
3.	The Sewing Process (AMH/N1948)	34
	Unit 3.1 - The Sewing Process	36
	Unit 3.2 - Stitching	41
	Unit 3.3 - Knowledge of Basic Embroidery Stitches	46
4.	Inspections and Alterations of Garments for Fittings (AMH/N1949)	52
	Unit 4.1 - Inspections and Alterations of Garments for Fittings	54
5.	Maintain Work-Area, Tools and Machines (AMH/N0102)	59
	Unit 5.1 - Maintain Work Area, Tools and Machines	61
6.	Comply with Industry, Regulatory and Organizational Requirements (AMH/N0104)	65
	Unit 6.1 - Comply with Industry, Regulatory and Organizational Requirements	67
	Unit 6.2 - Entrepreneurship	69
	Unit 6.3 - Documentation	71
7.	Soft Skills And Communication Skills	77
	Unit 7.1 - Introduction to the Soft Skills	79
	Unit 7.2 - Effective Communication	83
	Unit 7.3 - Grooming and Hygiene	88
	Unit 7.4 - Interpersonal Skill Development	94
	Unit 7.5 - Social Interaction	105
	Unit 7.6 - Group Interaction	109
	Unit 7.7 - Time Management	113
	Unit 7.8 - Resume Preparation	117
	Unit 7.9 - Interview Preparation	121

Table of Content

S. No.	Modules and Units	Page No.
8.	Maintain Health, Safety and Security in Tailoring Shop (AMH/N1950)	125
	Unit 8.1 – Maintain Health, Safety and Security in Tailoring Shop	127
	Unit 8.2 – First Aid and CPR	132
9.	Employability and Entrepreneurship Skills	135
	Unit 9.1 – Personal Strengths & Value Systems	138
	Unit 9.2 – Digital Literacy: A Recap	167
	Unit 9.3 – Money Matters	175
	Unit 9.4 – Preparing for Employment & Self Employment	191
	Unit 9.5 – Understanding Entrepreneurship	206
	Unit 9.6 – Preparing to be an Entrepreneur	228
10.	Annexures	245
	Annexure I: Training Delivery Plan	246
	Annexure II: Assessment Criteria	258





Skill India
शिक्षणं मरणं - कृषणं मरणं



GOVERNMENT OF INDIA
MINISTRY OF SKILL DEVELOPMENT
& ENTREPRENEURSHIP



N S D C
National
Skill Development
Corporation

Transforming the skill landscape



1. Introduction and Orientation

Unit 1.1 - Apparel Industry

Unit 1.2 - Role and Responsibilities of a Tailor



Key Learning Outcomes

At the end of this module, you will be able to:

1. Build rapport with fellow participants of the program
2. Discuss emerging trends in the sewing and apparel sector in India
3. Identify your roles and responsibilities
4. Familiarize the participants with the apparel industry
5. List the exact roles and responsibilities of a Self Employed Tailor and make the participants aware of the same.

UNIT 1.1: Apparel Industry

Unit Objectives

At the end of the unit, students will be able to:

1. Introduce each other
2. Build rapport with fellow students and the trainer
3. Introduce the students to the art of sewing
4. Make the students understand the large world of Apparels and introduce them to the the areas that they do not know.

Resources to be Used

- Available objects such as a duster, pen, notebook etc.

Activity

- Make the students stand in a circle, close enough to the person each side of them that they can pass the parcel quickly.
- Say 'Stop' when the when students least expect it. The person who has the parcel at that time should get out.
- Those who get out should introduce themselves by providing their names and a little additional information such as favourite hobbies, likes, dislikes etc.
- The winner of the game should stand and introduce himself/herself at the end of the game.
- Give the students the idea of how sewing can be seen as a new dimension of developing skill along with understanding their potentials when they introduce themselves.
- Make the students aware of the rising scope of the Apparel industry in India.

Say

- Thank the students for their participation.
- Ask them if they have any doubts
- Explain them the available scope in front of them.

Elaborate

Apparel Sector – Industry Overview

Indian Textile and Clothing (Apparel) industry is the second largest manufacturer in the world. The Indian textiles and clothing sector is expected to grow at 10.01 percent in the next 10 years from the current value of INR3.92 lakh crores in 2012–13 to INR7.54 lakh crores in 2021–22. Of these, the garments sector is estimated to grow at an average rate of 15.44 percent over the years, thereby accounting for about 70 percent of the total production

The Indian textile sub-sector has traditionally been contributing significantly to the economy and manpower as well as to the structural changes in the manufacturing sector. As of 2012, the sector contributed 4 percent of the GDP, 32 percent of the manufacturing sector and 9 percent of total exports

Trainer's Note:

- These are supporting content to the Participant Manual, please adhere to the Participant Manual and Explain the trainees' the concept

Notes for Facilitation

- You could ask the students who get out during the game to be the music keepers. They can start and stop the music as the game progresses.
- Encourage shy students to provide information about themselves by prompting them with questions such as 'what do you enjoy doing the most', 'what is your favorite movie or book' etc.
- Advise the students as to how can they enhance their skills and stand out off the crowd in the competitive world.

Suggestive Questions to ask students:

- Ask students to explain the employment scenario in the sector.
- Ask students to explain the actual & projected size of Indian Textile industry.

UNIT 1.2: Role and Responsibilities of a Tailor

Unit Objectives

At the end of the unit, students will be able to:

1. Paraphrase the job of SET
2. Familiarise with the roles and responsibilities of SET

Resources to be Used

- Available objects such as black or white Board, chalk pieces or white board marker pens, duster.
- PC with LCD Projector or Flip Chart
- Participant Manual
- Copies of Handouts

Do

- Greet and welcome the participants to the next session of the program.
- Before starting the session ask them do they have any doubts pertaining to the previous unit.
- Acknowledge their responses and clear their doubts if any.
- Tell them they will learn about the roles and responsibilities of Production Supervisor.

Say

- Tell them that they are going to learn about the Self Employed Tailor's job role. Self Employed Tailor is a role of a self employed professional tailor who can sew and repair garments, made ups and home-furnishing articles and manage livelihood out of it.
- Discuss with the participants about the Attributes of Self Employed Tailor. The tailor should have following attributes:
 - » Good eyesight, Eye-hand-leg coordination
 - » Motor skills
 - » Clear vision and free from colour vision.
 - » He/She should have good interpersonal skills, good listener and business acumen.
- Also tell them about the Duties and Responsibilities of a Production Supervisor.

Elaborate

Tailor's Duties and Responsibilities

- Refer to orders for sewing garments and select appropriate materials.
- Ensure that all materials and auxiliary supplies are available prior to beginning work.
- Start sewing machinery at the beginning of a shift and test it for proper functionality.
- Address any discrepancies or problems faced during the testing period.
- Draw threads through needles and adjust machine functions to meet the requirements of the sewing project.
- Position materials under needles to sew them together or make patterns.
- Replace and rethread needles for a subsequent project or in case of the existing one needing more thread.
- Sew missing stitches or replacement parts in accordance to repair instructions provided.
- Observe operations to detect any faults or defects in stitching.
- Notify supervisors of any problems or discrepancies during the sewing process.
- Attach button, grips, hooks and fasteners to finished garments.
- Attach elastic or tape to garments as specified in the work order.
- Ensure that the finished product conforms to the design and merchandising instructions provided in the work order.
- Ensure that excess material or threads are cut away from the finished product.
- Trim finished garments using scissors and cutters.
- Perform general and preventative maintenance tasks on sewing machines to ensure their longevity.
- Examine finished garments for compliance and ensure that appropriate tags are sewed on them.
- Count number of garments stitched during a shift and record this information in company provided logs.

Notes for Facilitation

- Summarize the main points.
- Ask participants if they have any doubts. Encourage them to ask questions.
- Answer their queries satisfactorily.
- Tell participants to complete the questions at the end of the unit.
- Ensure that every participant answer all the questions.

Suggestive Question to ask students:

- Ask students to explain the duties and responsibilities of Tailor.



Skill India
वीरता मर्यादा - कृपाया मर्यादा

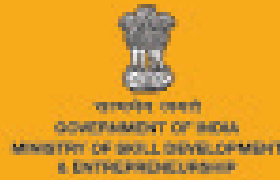

2. Drafting and Cutting the Fabric

Unit 2.1 - Tools and Equipment Required for Tailoring

Unit 2.2 - Types of Fabric

Unit 2.3 - Trims and Accessories

Unit 2.4 - Size Chart

Unit 2.5 - Taking Measurements

Unit 2.6 - Drafting and Cutting

Unit 2.7 - Types of Fabric Defects

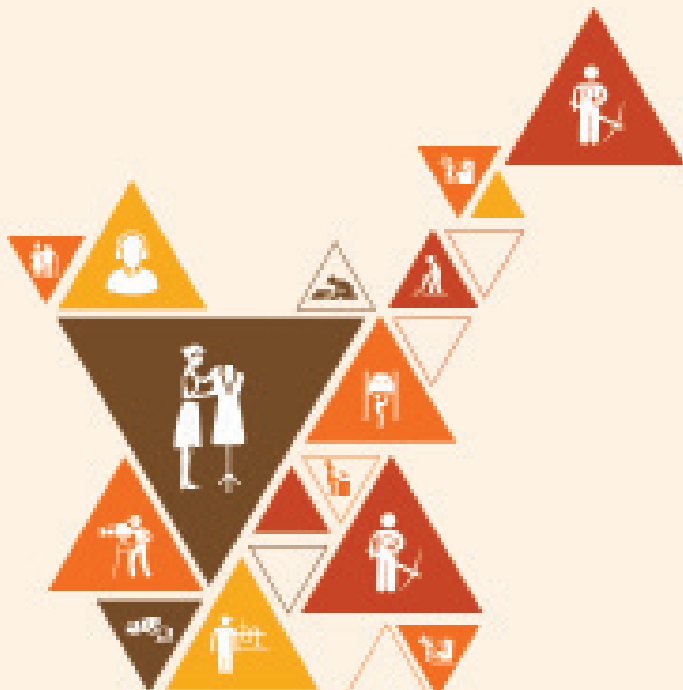

AMH/N1947

Key Learning Outcomes

1. Know and recognize the different types of material and tools used in stitching.
2. Understand the stitching terms.
3. Recognize the different types of fabric.
4. Recognize the trims and accessories
5. Understand the importance and use of trims and accessories
6. Understand the different size chart comparison tables
7. Know the different terms used in size charts
8. Know how to take measurements for different garments.
9. Understand different types of defects
10. Find and rectify the defects
11. Identify different types of faults

UNIT 2.1: Tools and Equipment Required for Tailoring

Unit Objectives

At the end of the unit, students will be able to:

1. Identify tools and equipment required in the job.

Resources to be Used

- Available objects such as a duster, pen, notebook etc.

Do

- Greet and welcome the participants to the next session of the program.
- Before starting the session ask them do they have any doubts pertaining to the previous unit.
- Capture their responses on board and share them wherever necessary.
- Tell them that they will learn about equipment readiness in this unit.

Say

- Tell the students about the basic tools and equipment like scissors, rotary cutter, thread, measuring tape, needles, fabric, pins, pincushion, iron and ironing board, seam ripper, pinking shears, cutting fig, sewing gauge, hem gauge, yardstick, hip curve, L-square, Tailor's Chalk, novelty yarns, masking tape, French curve, hand needle, punch needle, frame round, pattern making paper, tracing paper, hand held trimmer, bent neck, metallic tweezer, pencils, pick glass, needle threader, non-woven non-fusible backing paper, hand embroidery book, fabric glue, surface ornamentation materials, buttons, hooks, trims, lace, zipper, pant hooks, sewing mannequin, grayscale and thimble.
- Explain and demonstrate the sewing equipment to the students with the purpose for which each machine can be used Line Checker.

Demonstrate

Scissors: It's possible to use non-sewing scissors for sewing, but you will make your life much easier by using scissors that are specific to your project. General sewing scissors used for cutting fabric have a handle aligned with the blade so that you can keep the scissors even while cutting through the fabric, which prevents jagged cuts. Pinking shears are another type of scissors used in sewing because their edges prevent woven fabrics from fraying and give a finished look to fabric.



Fig.2.1.1: Scissors

Rotary cutter: Another kind of tool use to cut fabric is the rotary cutter.



Fig.2.1.2: Rotary cutter

The rotary cutter uses a blade to cut easily and smoothly through fabric. It is excellent to use in all projects, but especially for quilting. You need a rubber cutting mat and a rotary ruler for when you're using a rotary cutter to prevent the rotary cutter from cutting into the surface of the table and to keep the line you're cutting straight.



Fig.2.1.3: Threads

Thread: Thread is available in a rainbow of colors, including clear. For most sewing machines you'll need a spool of thread that looks like this (the cone shaped threads are for a different kind of machine called a serger). When picking out thread, if you're trying to match it exactly to the fabric color you should remember that thread looks lighter once it is sewn.



Fig.2.1.4: Measuring tape

Measuring tape and/or a ruler: The measuring tape used for the purpose of cutting and sewing is different than the one used in construction projects. This tape is supposed to be softer, so that it is easier for the operator to fit clothing to the body. A ruler can also helpful when doing specific seam lengths.

Needles: A sewing machine requires different needles than those used for hand-sewing; machine needles have a larger, blunter tip where they fit into the machine. Different types of needles are used on different kinds of projects, but all-purpose sewing needles are sold. For more information about the types of needles, this article takes an in-depth look at the structure of a needle and the different kinds that are produced.



Fig.2.1.5: Needles

Trainer's Note:

- These are supporting content to the Participant Manual, please adhere to the Participant Manual and Explain the trainees' the concept.

Say 

- Tell the participants about sewing equipment also.

Notes for Facilitation 

- Ask participants what are the key attributes and role of an inline checker.
- Tell participants to complete the questions at the end of the sub unit.
- Ask participants if they have any doubts. Encourage them to ask questions.
- Answer their queries satisfactorily.

Suggestive Questions to ask students:

- Ask students to list tools and equipments required for drafting and cutting of the fabric.
- Ask students to define basic tools and equipments required for drafting & cutting of the fabric.

UNIT 2.2: Types of Fabric

Unit Objectives

At the end of the unit, students will be able to:

1. Recognize the different types of fabric.

Resources to be Used

- Available objects such as a duster, pen, notebook etc.

Do

- Greet and welcome the participants to the next session of the program.
- Before starting the session ask them do they have any doubts pertaining to the previous unit.
- Capture their responses on board and share them wherever necessary.
- Tell them that they will learn about equipment readiness in this unit.

Say

- Tell the participants about different types of fabric used in Indian industry. Discuss the classification of the fabric with participants.

Elaborate

Fabric can be classified into two types:

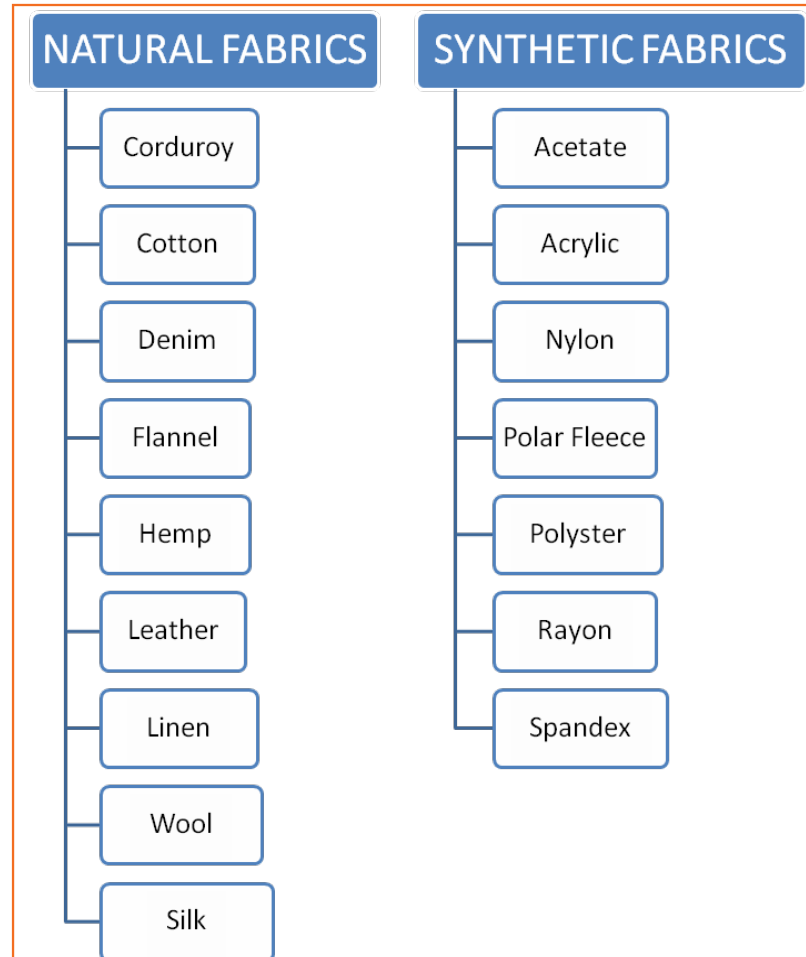

Fig.2.2.1: Types of fabric

Demonstrate

Silk

Silk is a natural protein fibre. It is a delicate fabric and is very light weight and due to these features it has a free flowing and smooth drape. It has a slightly shimmery appearance. It is a difficult fabric to work with as it is very slippery. Its elasticity is very moderate to poor. Apparels made of silk have to be Dry cleaned.



Fig.2.2.2: Silk

Trainer's Note:

- These are supporting content to the Participant Manual, please adhere to the Participant Manual and Explain the trainees' the concept.

Notes for Facilitation

- Ask participants what are the key attributes and role of an inline checker.
- Tell participants to complete the questions at the end of the sub unit.
- Ask participants if they have any doubts. Encourage them to ask questions.
- Answer their queries satisfactorily.

Suggestive Questions to ask students:

- Ask students to explain different types of fabric used in Indian industry.
- Ask students to classify fabrics into two types.

UNIT 2.3: Trims and Accessories

Unit Objectives

At the end of the unit, students will be able to:

1. Recognise the trims and accessories
2. Understand the importance and use of trims and accessories

Resources to be Used

- Available objects such as black or white Board, chalk pieces or white board marker pens, duster
- PC with LCD Projector or Flip Chart
- Copies of handouts, Participants Handbook

Do

- Greet and welcome the participants to the next session of the program.
- Before starting the session ask them do they have any doubts pertaining to the previous unit.
- Capture their responses on board and share them wherever necessary.
- Tell them that they will learn about Finishing Department Workflow

Say

- Recite to them the trims and accessories are a considered as an important part of any garment. Apart from enhancing the look of the garment it also increases the usability of the garment.

Elaborate

Sewing Thread

The sewing thread holds the garment together. It is a specially designed yarn which passes through a sewing machine easily and makes the sewing process smoother and easier.



Fig.2.3.2: Interlining

Lace

Is a delicate fabric which is made either of thread or yarn. It is used on garments for ornamental purpose.



Fig.2.3.4: Buttons

Label

It is used in every garment. More than one label can be found in every garment and each label provides different required information. Size label, Main label (Name of the company), Price tag label, Composition label, Fabric Care label etc. are some of the labels you can find on garments.



Fig.2.3.1: Sewing Thread

Interlining

It is fabric which is placed under the main fabric. It is used to enhance the look and retain the shape of the garment. Lining should be chosen carefully as it can influence the colour of the garment if it is different from the colour of the main fabric.

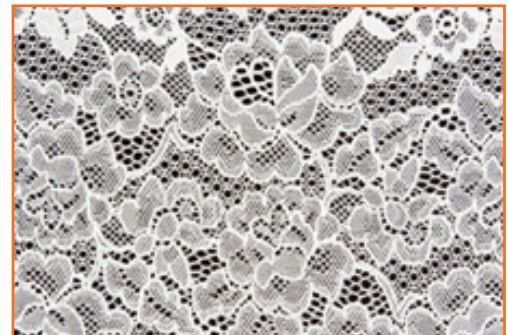

Fig.2.3.3: Lace

Buttons

Button is a fastener which is used to temporarily secure two pieces of fabric together. It is an accessory which is commonly used in garments. It can be used for both functional and decorative purpose.



Fig.2.3.5: Label

Trainer's Note:

- These are supporting content to the Participant Manual, please adhere to the Participant Manual and Explain the trainees' the concept.

Notes for Facilitation 

- Ask participants what are the key attributes and role of an inline checker.
- Tell participants to complete the questions at the end of the sub unit.
- Ask participants if they have any doubts. Encourage them to ask questions.
- Answer their queries satisfactorily.

Suggestive Questions to ask students:

- Ask students to explain the importance of Trims & Accessories.
- Ask students to list Trims & Accessories.

UNIT 2.4: Size Chart

Unit Objectives

At the end of the unit, students will be able to:

1. Understand the different size chart comparison tables
2. Know the different terms used in size charts

Resources to be Used

- Available objects such as black or white Board, chalk pieces or white board marker pens, duster
- PC with LCD Projector or Flip Chart
- Copies of handouts, Participants Handbook

Do

- Greet and welcome the participants to the next session of the program.
- Before starting the session ask them do they have any doubts pertaining to the previous unit.
- Capture their responses on board and share them wherever necessary.
- Tell them that they will learn about Finishing Department Workflow

Say

- Tell the participant about the size charts being used world wide in garment industry. Debrief them that each country formulates and follows its own size charts taking into account the body type and measurements of the general population in the country.
 - » Womens size chart comparison table
 - » Mens size chart comparison table
 - » Kids size chart comparison table
 - » Terms used in size chart

Elaborate

Womens size chart

United States	0	2	4	6	8	10	12	14	16	18	20	22	24
UK	4	6	8	10	12	14	16	18	20	22	24	26	28
Germany	30	32	34	36	38	40	42	44	46	48	50	52	54
France	32	34	36	38	40	42	44	46	48	50	52	54	56
Italy	36	38	40	42	44	46	48	50	52	54	56	58	60
Korea	44	44	55	55	66	66	77	77	88	88			

Fig.2.4.1(a): Womens size chart

Bust	32"	34"	36"	38"	40"
	81 cm	86 cm	91 cm	97 cm	102 cm
Waist	24"	26.5"	29"	31"	33"
	61 cm	67 cm	74 cm	79 cm	84 cm
Hip	35"	37"	39"	41"	43"
	89 cm	94 cm	99 cm	104 cm	109 cm

Fig.2.4.1(b): Womens size chart

Mens size chart

UK & other EU / Japan	36	37	38	39	40	41	42	43	44	45	46
UK / US / AUS	14	14½	15	15½	15¾	16¼	16½	17	17½	18	18½
Japan ^[6]	S	S	M	M	L	L	LL,XL	LL,XL	LL,XL		
Korea ^[6]	90		95		100		105		110		

Fig.2.4.2(a): Mens size chart

EU	64/68	68/72	72/76	76/80	80/84	84/88	88/92	92/96	96/100	100/104	104/108	108/112	112/116
Italy	43	44	45	46	47	48	49	50	51	52	53	54	55
UK / US	27	28	29	30	31	32	33	34	36	38	40	42	44

EU	34	36	38	40	42	44	46	48
UK / US	25/26	27/28	29/30	31	32	33	34	36

Fig.2.4.2(b): Mens size chart

Say

- Tell them that a measuring tape is a common measuring tool used by all tailors. It is a flexible ruler with linear measurement markings on it. It consists of a ribbon of cloth, plastic, fibre glass, or metal strip. Its flexibility allows for a measure of great length permits one to measure around curves or corners.

Elaborate

Understanding the markings on the measuring tape

Inches: Inches are the long lines that cross either half of, or all of the 1" width of the measuring tape. They usually are preceded or followed by numbers

- $1/2$ of an inch is half of 1 inch.
- $1/4$ of an inch is every four marks on the measuring tape
- $1/8$ of an inch is twice as big as the $1/16$ of an inch. It is every other mark
- $1/16$ of an inch is usually the smallest

Measurement on a tape measure. The distance between every line on the tape measure is $1/16$ of an inch $1/32$ of an inch is even more smaller which only certain measuring tapes indicate. The distance between every line on the tape measure is $1/32$ of an inch

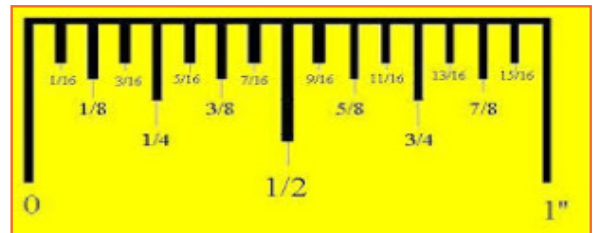

Fig.2.4.5: Measuring tape

Understanding Fractions

To divide the measuring tapes into inches, various fractions are used on the measuring tape ($1/16$, $1/8$, $1/4$, $1/2$ etc.). The figure indicates the various fractions of an inch of measurement.

Trainer's Note:

- These are supporting content to the Participant Manual, please adhere to the Participant Manual and Explain the trainees' the concept.

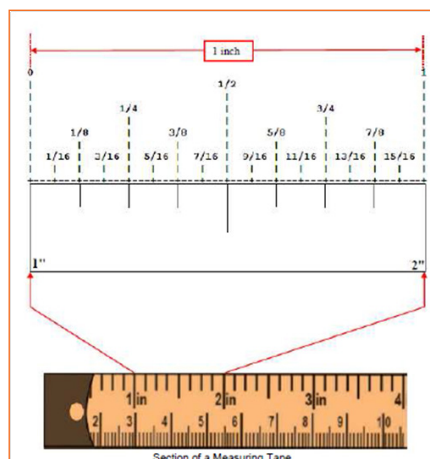

Fig.2.4.6: Fractions in a Measuring tape

Notes for Facilitation

- Ask participants what are the key attributes and role of an inline checker.
- Tell participants to complete the questions at the end of the sub unit.
- Ask participants if they have any doubts. Encourage them to ask questions.
- Answer their queries satisfactorily.

UNIT 2.5: Taking Measurements

Unit Objectives

At the end of the unit, students will be able to:

1. Take measurements for different garments.

Resources to be Used

- Available objects such as black or white Board, chalk pieces or white board marker pens, duster
- PC with LCD Projector or Flip Chart
- Copies of handouts, Participants Handbook

Do

- Greet and welcome the participants to the next session of the program.
- Before starting the session ask them do they have any doubts pertaining to the previous unit.
- Capture their responses on board and share them wherever necessary.
- Tell them that they will learn about Finishing Department Workflow

Say

- Tell the participant about the different methods and areas of measurement. Show them how to take measurement for garments stitching.

Demonstrate

Bust: Raise the arm to the shoulder level. The measuring tape should cross around the fullest part of the bust. The measuring tape should run directly over the nipples and across the shoulder blades on the back.

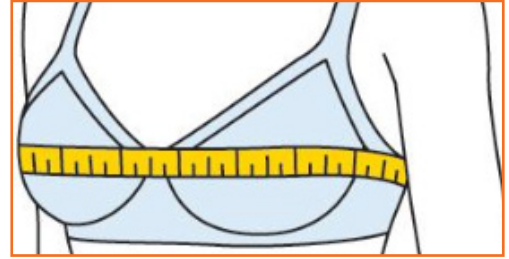

Fig.2.5.1: Bust



Fig.2.5.2: Waist

Waist: The measurement should be taken around the narrowest point of the waistline allowing 2 fingers between the waist and the tape measure.

Hips: Standing with the knees together, the measurement should be taken around the fullest part of the hips.



Fig.2.5.3: Hips



Fig.2.5.4: Shoulder to Bust

Shoulder to Bust: Run the measuring tape from the tip of the shoulder to the centre of bust.

Front Shoulder to Waist: Measure from tip of shoulder over bust to natural waistline.

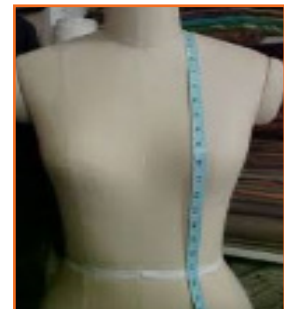

Fig.2.5.5: Front Shoulder to Waist



Fig.2.5.6: Shoulder to Shoulder

Shoulder to Shoulder: Measure across the back of neck from the socket of one shoulder to the socket of the other shoulder.

Say

Tell them how to take measurement for shirt, trousers etc.

Demonstrate

Neck: The measuring tape should be held around the neck line and just below the Adam's apple



Fig.2.5.20: Full chest

Shoulder width: The tape is held from one shoulder point to the other.



Fig.2.5.22: Right sleeve

Bicep: Measure around the fullest part of the bicep in line with the armpit.

Trainer's Note:

- These are supporting content to the Participant Manual, please adhere to the Participant Manual and Explain the trainees' the concept.



Fig.2.5.19: Neck

Full chest: The tape should cover the fullest part of the chest. The tape should be held right under the armpits and shoulder blades and across the nipples.



Fig.2.5.21: Shoulder width

Right sleeve: Taken from the shoulder tip point down to the desired sleeve length. (The same process is followed for both left and right sleeve measurement)



Fig.2.5.23: Bicep

Notes for Facilitation

- Ask participants what are the key attributes and role of an inline checker.
- Tell participants to complete the questions at the end of the sub unit.
- Ask participants if they have any doubts. Encourage them to ask questions.
- Answer their queries satisfactorily.

Suggestive Questions to ask students:

- Ask students to explain different methods of measurement.
- Ask students to list different areas of measurement.

UNIT 2.6: Drafting and Cutting

Unit Objectives

At the end of the unit, students will be able to:

- Understand drafting and cutting
- Draft the garments
- Cut the garments

Resources to be Used

- Available objects such as black or white Board, chalk pieces or white board marker pens, duster
- PC with LCD Projector or Flip Chart
- Copies of handouts, Participants Handbook

Do

- Greet and welcome the participants to the next session of the program.
- Before starting the session ask them do they have any doubts pertaining to the previous unit.
- Capture their responses on board and share them wherever necessary.
- Tell them that they will learn about Finishing Department Workflow

Say

- Tell the participants how to draft and cut long sleeve shirt for man. Explain that the long sleeve shirt is a common wear of men used as upper body wear. Example shown in section 2.6.2 has following details.

Selected fabrics: poplin, cotton, silk, crepe, polyester, oxford cotton.

Materials required: 2.50 mts cloth width is 36"

Measurement required:

- back length = 32"
- n.w length = 17"
- shoulder width = 17"
- chest = 36"

- waist = 32"
- hip or seat = 38"
- sleeve length = 24"
- cuff size = 2 ½" * 11"
- pocket size = 5" * 5 ½"

Elaborate

Drafting details front part:

- 1-2 = full length + 1".
- 1-3 = chest/4(-) ½", arm depth.
- 1-4 = 1/6th neck measure.
- 4-4a = 1" as per draft.
- 4a-4b = ¾" for button stand.
- 4b-6 = 1 ½" for placket.
- 4b-2b = draw a line as per draft.
- 6-6a = draw a line as per draft.
- 1-7 = 1/2 shoulder width + 1/2" for seam.
- 7-8 = draw a line.
- 3-9 = 1/3rd chest measure.
- 10-4 = 1/6th neck measure.
- 10-11 = draw line as per draft.
- 10-12 = 1" as per draft.
- 13-7 = shoulders slope 1 ½".
- 14-2 = same as 9-3 measure.
- 14-15 = 4 ½" as standard measure.
- 14-16 = 5 ½" as standard measure.
- 17-8 = 1" as per draft.
- 18 is a middle measure of 13-8 distance
- 18-19 = 3/4" as per draft.
- 13,19,17,19 = draw arm hole shape with arm curve.
- Cut the front part.

Trainer's Note:

- These are supporting content to the Participant Manual, please adhere to the Participant Manual and Explain the trainees' the concept.

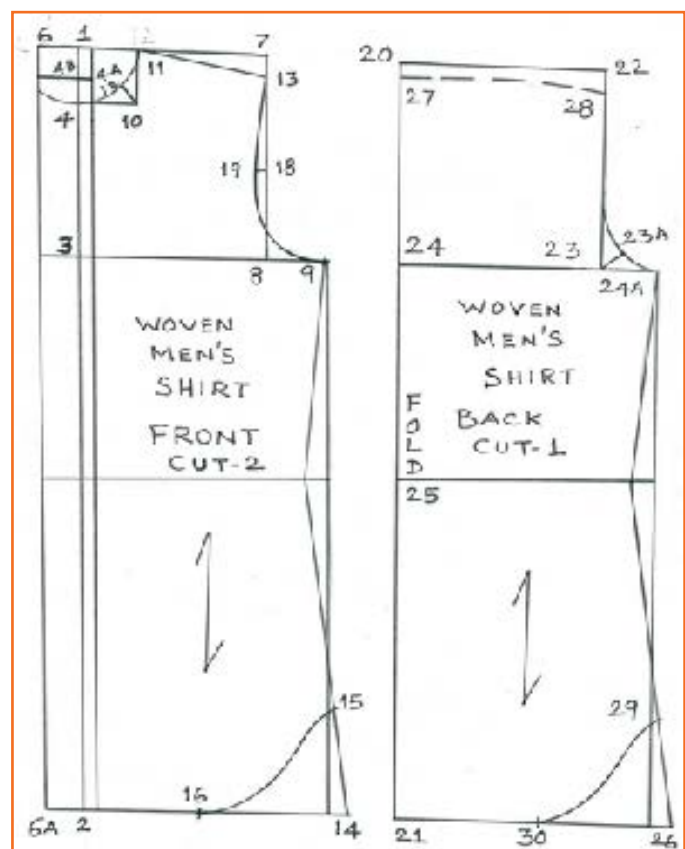

Fig.2.6.1: Drafting of front and back part

Say

- Ask the participant to draft and cut a saree blouse. Tell them about the different parts of a saree blouse.

Elaborate

Drafting & Cutting Instructions For A Basic Blouse With Waistline Dart

Front Part:

1. Square down centre front line and shoulder lines.
 - » Centre Front Line: Waist Length + 1cm for seam allowance at shoulder + 1cm seam allowance at waist
 - » Shoulder Line: $\frac{1}{2}$ of Shoulder Measurement + 1cm seam allowance. Shoulder can be taken square or sloped. This depends up on the garment to be made. Since a sari blouse is usually of wide neck, no slope is suggested here.
2. Square Armscye Depth down the Centre Front Line. Take $\frac{1}{4}$ th of the Bust Circumference + 1cm ease + 5cm seam allowance, horizontally. This wide seam allowance is useful for alterations.

Trainer's Note:

- These are supporting content to the Participant Manual, please adhere to the Participant Manual and Explain the trainees' the concept.

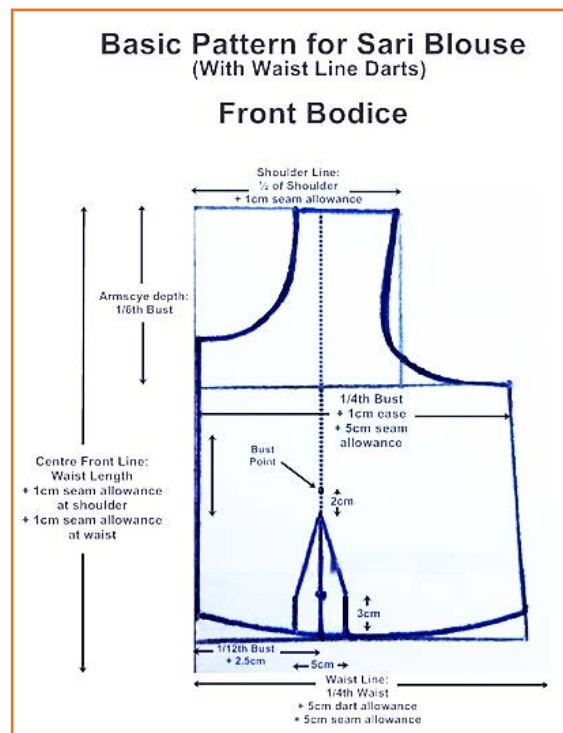

Fig.2.6.3: Front bodice of saree blouse

Say

- Ask the participant to draft and cut a kurta or kameej. Tell them about the different parts of a kurta or kameej.
- Also tell them that Kameez or Kurta is a traditional costume of India. It is used along with Salwar, Churidar or denim pants. The neckline can be shaped according to fashion. This garment is basically cut into three pieces, the front, back and sleeve. Darts are used to give fit or shape to the garment.

Elaborate

The construction of Kameez may look long but it is very easy, just follow the instructions and you will end up with your own Kameez top.

Measurement

- Square Neck: 14 Inches
- Across Shoulder: 14 inches
- Chest: 36 inches
- Waist: 28 inches
- Hip: 38 inches
- Length of Top: 25 inches

Material Required:

- 1¼ Mtrs of fabric

Trainer's Note:

- These are supporting content to the Participant Manual, please adhere to the Participant Manual and Explain the trainees' the concept.

Say

- Ask the participant to draft and cut a pant. Tell them about the different parts of a pant.
- Tell them to draft a pants, you'll need to do a little math. First, take your child's hip measurement and divide it by 2. Then add 9 inches. Call this number A. Next, add the rise plus the inseam. Call this number B. Draw a rectangle that is A wide by B tall.

Notes for Facilitation

- Ask participants what are the key attributes and role of an inline checker.
- Tell participants to complete the questions at the end of the sub unit.
- Ask participants if they have any doubts. Encourage them to ask questions.
- Answer their queries satisfactorily.

Suggestive Question to ask students:

- Ask students to explain the instructions of drafting and cutting for a basic blouse with waistline dart.

Suggestive Question to ask students: (for Practical session)

- Ask students to cut & draft a garment.

UNIT 2.7: Types of Fabric Defects

Unit Objectives

At the end of the unit, students will be able to:

1. Understand defects
2. Understand types of defects
3. Identify different types of faults

Resources to be Used

- Available objects such as a duster, pen, notebook etc.



Do

- Greet and welcome the participants to the next session of the program.
- Before starting the session ask them do they have any doubts pertaining to the previous unit.
- Capture their responses on board and share them wherever necessary.
- Tell them that they will learn about equipment readiness in this unit.

Say

- Tell the participants about various categories of defects.
- Discuss with them the classification of defects and the factors that should be considered before classifying them.
- Explain the different types of faults.
- Tell them about the various processes to recognise and rectify defects.

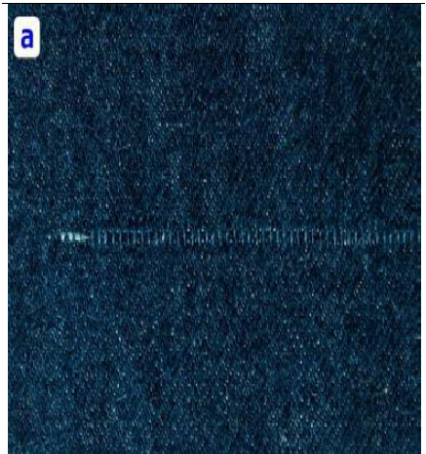
Common Woven and Knit Fabric Defects

Defect	Explanation	Severity	Photograph
Defects of Woven Fabric			
Dropped Pick	Caused by the filling insertion mechanism on a shuttle less loom not holding the filling yarn, causing the filling yarn to be woven without tension. The filling yarn appears as "kinky."	Major	
End Out	Caused by yarn breaking and loom continuing to run with missing end.	Major	
Slub	Usually caused by an extra piece of yarn that is woven into fabric. It can also be caused by thick places in the yarn. Often is caused by fly waste being spun in yarn in the spinning process.	Major or Minor	

Trainer's Note:

- These are supporting content to the Participant Manual, please adhere to the Participant Manual and Explain the trainees' the concept.

Say 

- Tell the participants how to care fabric. Explain that the proper care of clothes ensures that the garments last longer and gives one value for money and look great after a number of washings

Elaborate

Safe Ironing temperatures limits for fabrics

Cotton	400 o -425o F
Linen	450 o F
Silk	300 o F
Wool	300 o F
Nylon	300 o -350 o F
Polyester	325 o F
Rayon	350 o -375 o F (Reverse and iron)
Rubber	Do not iron

Fig.2.7.16: Safe Ironing temperatures limits for fabrics

Notes for Facilitation

- Ask participants what are the key attributes and role of an inline checker.
- Tell participants to complete the questions at the end of the sub unit.
- Ask participants if they have any doubts. Encourage them to ask questions.
- Answer their queries satisfactorily.

Suggestive Questions to ask students:

- Ask students to list various categories of defects.
- Ask students to explain defects of knitted fabric.



Skill India
शिक्षणं मरणं - कृषणं मरणं

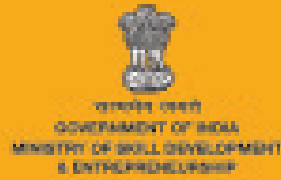

3. The Sewing Process

Unit 3.1 - The Sewing Process

Unit 3.2 - Stitching

Unit 3.3 - Knowledge of Basic Embroidery Stitches

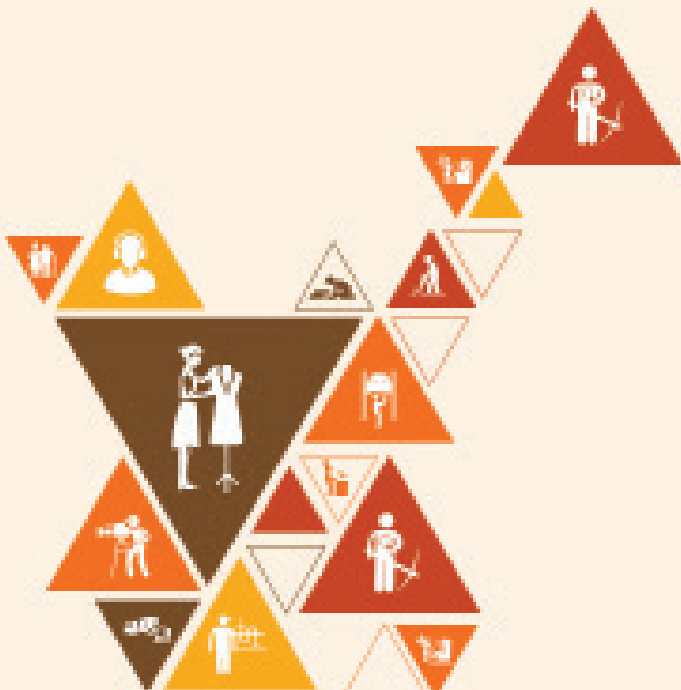

AMH/N1948

Key Learning Outcomes

At the end of the module, you will be able to:

1. Recognize the different types of sewing machine and understand the different parts of a sewing machine
2. Thread a sewing machine
3. Understand the different hand sewing methods
4. Understand flat stitches, loop stitches and knotted stitches
5. Carry out flat stitches, loop stitches and knotted stitches

UNIT 3.1: The Sewing Process

Unit Objectives

At the end of the unit, students will be able to:

1. Recognize the different types of sewing machine and understand the different parts of a sewing machine
2. Thread a sewing machine
3. Understand the different hand sewing methods

Resources to be Used

- Available objects such as a duster, pen, notebook etc.

Do

- Greet and welcome the participants to the next session of the program.
- Before starting the session ask them do they have any doubts pertaining to the previous unit.
- Capture their responses on board and share them wherever necessary.
- Tell them that they will learn about equipment readiness in this unit.

Say

- Tell the students about the sewing process. Explain that in accordance with the job requirement, the tailor uses different types of sewing machines. These machines have to be chosen and handled with care to provide best results.

Elaborate



Lockstitch sewing machine: Also called the domestic sewing machine, this is a regular and popular machine which is used at home and also in schools. It is run manually but also can be converted to electric power machine.



Fig.3.1.2: Single needle lock stitch machine

Embroidery Machine: This is used in making diverse kinds of embroidery and fancy stitches on fabrics. This machine is popularly used in making pillow cases, linen, and other novelty.



Fig.3.1.4: Button Holer Machine

Button Attachment Machine: This machine is used in attaching buttons to the garments



Fig.3.1.6: Bartacking Machine



Fig.3.1.1: Hand driven Lockstitch sewing machine

Single needle lock stitch machine: It is modern high quality the color LCD touch panel sewing machine which reduces the disposition of the thread ends.

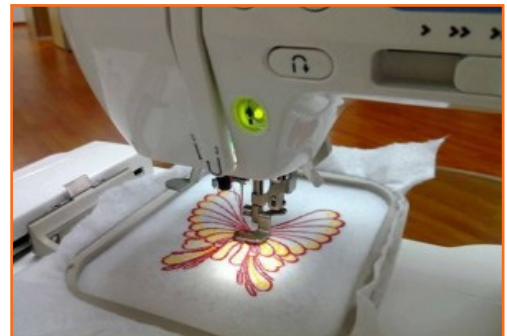

Fig.3.1.3: Embroidery Machine

Button Holer Machine: As the name of the machine suggests This is used in making buttonholes on garments.



Fig.3.1.5: Button Attachment Machine

Bartacking Machine: This is used in reinforcing the opening and closing of pockets.

Trainer's Note:

- These are supporting content to the Participant Manual, please adhere to the Participant Manual and Explain the trainees' the Demonstration of Parts of a Basic Sewing Machine and their Functions.

Elaborate

How to Thread a Sewing Machine

1. Place the presser foot in the upward position. Place a spool of thread on the spool holder. Traveling from the spool holder, across the top of the machine, look for a minimum of one thread guide. Insert the thread in the thread guide(s).
2. Now look for a tension mechanism. Bring the thread downward to the tension mechanism, slip the thread between the metal disks of the tension mechanism, and travel back upwards with the thread.
3. Look for a take up mechanism. This is the area on the front of the machine which will go up and down, when you turn the hand wheel. Place the thread through the take up lever. Some machines are set up so the thread will slide in to this, others require you to place the thread through a hole.
4. Now the thread will go downward on the left side of the take up lever.
5. Locate and thread any thread guides, leading down to the sewing machine needle.
6. Thread the sewing machine needle. Hold the thread with your left hand and turn the hand wheel.
7. Watch for any thread to flap around. If this happens, you have probably missed a thread guide.

Say

- Now tell them about common sewing machine problems. Tell them that a Tailor should know how to tackle simple sewing machine problem. Below is the checklist for machine problems and the best ways to solve them.

Elaborate

Machine troubles	Causes	Remedies
Skipped stitches	<ul style="list-style-type: none"> • Defective machine needle • Low pressure on the presser foot 	<ul style="list-style-type: none"> • Replace the needle • Increase pressure on the presser foot.
Knotting or breaking thread	<ul style="list-style-type: none"> • Bad quality thread • Machine is threaded wrongly • Bobbin and Bobbin case is threaded incorrectly. 	<ul style="list-style-type: none"> • Completely un-thread your sewing machine and re-thread it. • Thread it correctly.

Machine runs noisily	<ul style="list-style-type: none"> • Insufficient oil • Loose screw 	<ul style="list-style-type: none"> • Oil the sewing machine • Tighten the screws
Thread bunching or "Birds nesting "	<ul style="list-style-type: none"> • Tension setting is too low • The thread is positioned wrongly • The bobbin case is positioned incorrectly 	<ul style="list-style-type: none"> • Reset the tension • Re-thread the top thread ensuring the threading line indicator on the hand wheel is positioned to the top • Check the position of your bobbin case and reset as per instruction manual
Fabric not feeding	<ul style="list-style-type: none"> • Feed has not been accidentally lowered. • Stitch regulator not set on zero • Too tight pressure on presser foot 	<ul style="list-style-type: none"> • Raise the feed to ensure the fabric will move forward. • Adjust stitch regulator to desired stitch length • Add pressure to presser foot by adjusting the pressure regulator screw

Fig.3.1.9: Common Sewing Machine Problems and their Solutions

Say

- Tell the participants about the different hand sewing methods. Every tailor should know a few of the basic hand stitching methods. The popularly used hand stitching methods are listed below.

Elaborate



Running Stitch: Push point of needle in and out of fabric until you have several stitches on the needle. Hold fabric taut with left hand, pull the needle through. It's the basic stitch in hand-sewing and embroidery, on which all other forms of sewing are based.

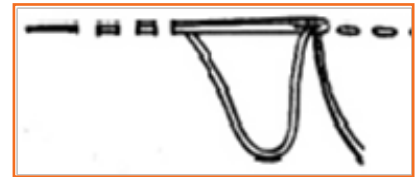

Fig.3.1.10: Running Stitch



Fig.3.1.11: Back Stitch

Back Stitch: It is used in strengthening a seam made by hand.

- Make a running stitch
- Take a back stitch to the beginning of the first stitch, overlapping each running stitch.

Trainer's Note:

- These are supporting content to the Participant Manual, please adhere to the Participant Manual and Explain the trainees' the concept and Demonstrate the concepts (For Example: Preparation of Pocket Bag (Front); Pocket Attaching (Front) ; Fly Making and Attaching; Sipper Attaching and etc

Say



- Tell the participants that now they will learn how to make a simple apron with pocket. Give them a demonstration on it.

Notes for Facilitation



- Ask participants what are the key attributes and role of an.
- Tell participants to complete the questions at the end of the sub unit.
- Ask participants if they have any doubts. Encourage them to ask questions.
- Answer their queries satisfactorily.

Suggestive Questions to ask students:

- Ask questions to list different types of sewing machine.
- Ask students to explain different parts of a sewing machine.

UNIT 3.2: Stitching

Unit Objectives

At the end of the unit, students will be able to:

1. Recognize the different parts of a trouser and a shirt.
2. Stitch trouser and shirt.

Resources to be Used

- Available objects such as a duster, pen, notebook etc.

Do

- Greet and welcome the participants to the next session of the program.
- Before starting the session ask them do they have any doubts pertaining to the previous unit.
- Capture their responses on board and share them wherever necessary.
- Tell them that they will learn about equipment readiness in this unit.

Say

- Tell the students about the different parts of a trousers. Demonstrate them the process of stitching a trousers.

Elaborate

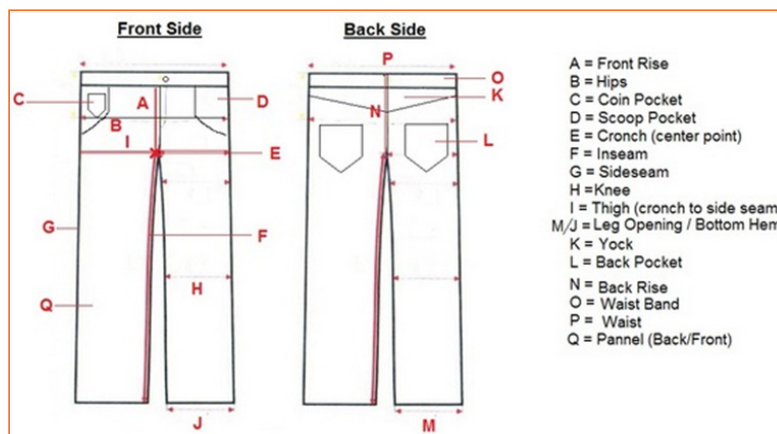

Fig 3.2.1: Parts of a trouser

Trainer's Note:

- These are supporting content to the Participant Manual, please adhere to the Participant Manual and Explain the trainees' the concept and Demonstrate the concepts (For Example: Preparation of Pocket Bag (Front); Pocket Attaching (Front) ; Fly Making and Attaching; Sipper Attaching and etc.

Say 

- Tell the participants about the different parts of a shirt. Also demonstrate them the process of stitching a shirt.

Elaborate **Parts of a Shirt**

Fig 3.2.2: Parts of a Traditional Shirt

Trainer's Note:

- These are supporting content to the Participant Manual, please adhere to the Participant Manual and Explain the trainees' the concept.

Say 

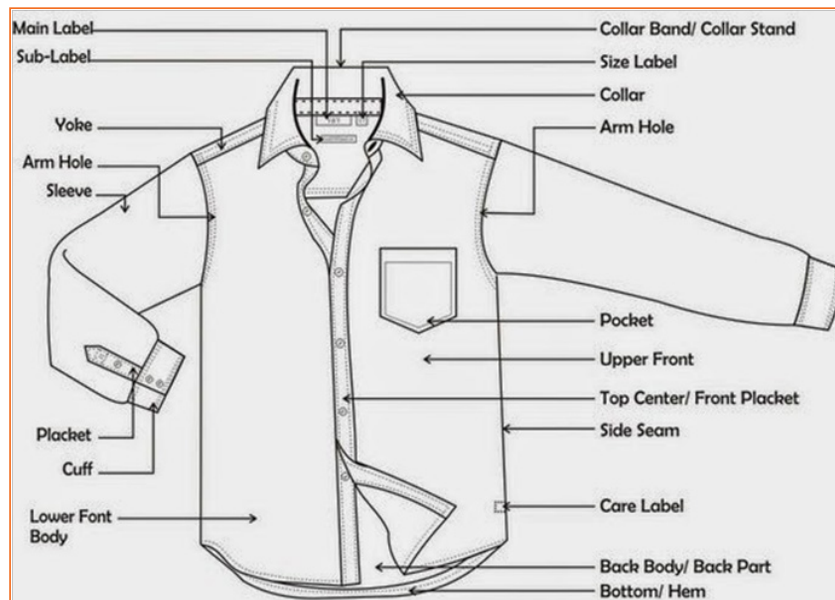
- Tell the participants about the different parts of a saree blouse. Also demonstrate them the process of stitching a saree blouse.

Elaborate

Measurements needed

- Chest
- Full length of the blouse
- Shoulder
- Sleeve length
- Sleeve round
- Front length-Measured from shoulder along the highest point of bust to where bra cup ends.

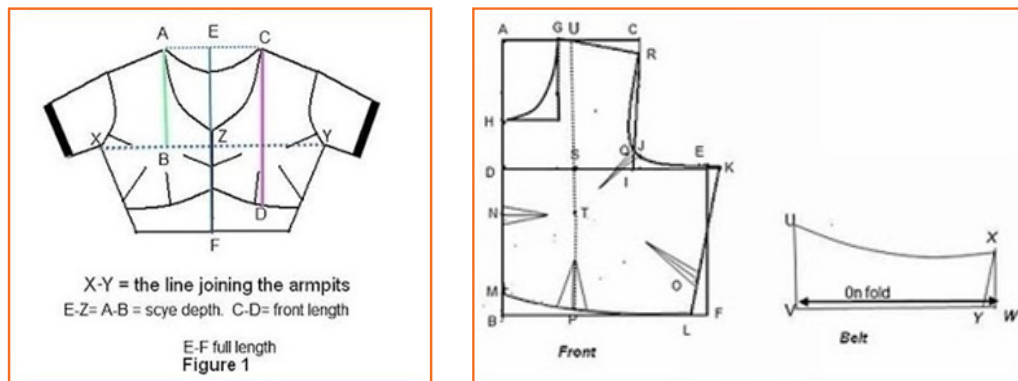

Fig 3.2.3: Drafting of a saree blouse

Trainer's Note:

- These are supporting content to the Participant Manual, please adhere to the Participant Manual and Explain the trainees' the concept.

Demonstrate

Stitching a saree blouse:

- **Step 1** Stay stitch neck, arm scyes and sleeve top.
- **Step 2** Stitch darts.
- **Step 3** Attach the belt to the body.
- **Step 4** Stitch button stands. Right side should overlap the left side. Extension is stitched to the left side and right side is finished with a facing.
- **Step 5** Join shoulders.
- **Step 6** Finish neck line with Piping or flat facing.
- **Step 7** Hem the lower edge of the sleeves and back.
- **Step 8** Attach sleeves to the body, matching center line of the sleeves to the shoulder line and easing wherever necessary.
- **Step 9** Stitch sides of the sleeves and body.
- **Step 10** Sew hook on the underside of right button stand and work eyes on the right side of left front facing.

Say 

Tell the participants about the different parts of kurta. Also demonstrate the process of stitching a kurta.

Demonstrate 

Stitching a Kurta/Kameez

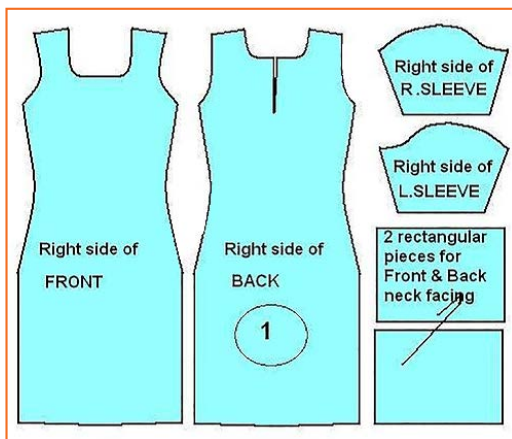

STEP 1: Take 2 Pieces of Kameez (Front and Back)
2 Pieces of Sleeve (Right and Left) and 2 rectangular pieces for Neck facing.

Trainer's Note:

- These are supporting content to the Participant Manual, please adhere to the Participant Manual and Explain the trainees' the concept.

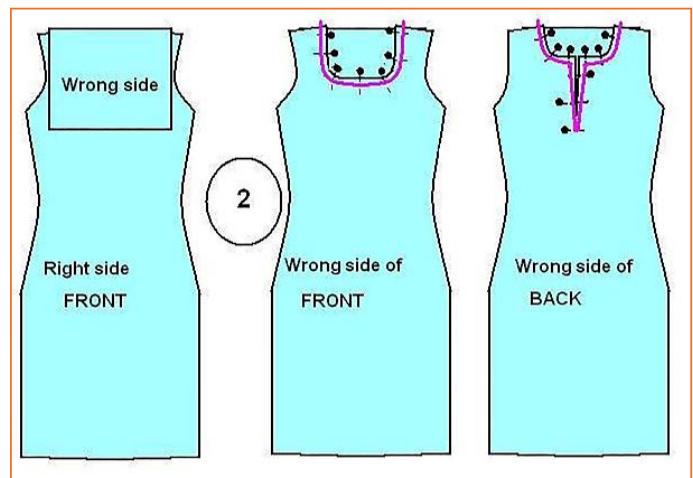

STEP 2: Place the neck facing rectangular pieces for the front and back Kameez pieces respectively. Make sure that the right sides are together. Pin and sew along the neck line with $\frac{1}{4}$ " seam allowance. Cut the excess of facing pieces and make notches on seam. Then turn right sides out and press. Give topstitch at neckline.

Say 

- Tell the participants how to stitch button and make button holes in garments.

Elaborate



Buttons: The various types of buttons available in the market differ in that they have different number of holes – 2 or 4. The method for fixing them remains the same. The spot where the button needs to be fixed is determined and then the needle is taken out first from one and then the other to properly fix the button. There should be a little looseness in the stitch so that the button can be easily passed through the button hole.



Fig 3.2.6: Button attaching

Button hole

Of utmost importance in the tailoring trade, as it is used on almost all types of garments – ladies, men's and children. There is a need to keep an opening somewhere on the garment for ease of wearing and taking off. Most of such openings are closed with the help of buttonhole stitches. The button hole is always made on the top portion. The buttonhole stitch is used to finish the button hole. It is made on two or more layers of cloth. The button hole has a slight curve on one side known as the fan and an edge on the other known as the bar.

Trainer's Note:

- These are supporting content to the Participant Manual, please adhere to the Participant Manual and Explain the trainees' the concept.

Notes for Facilitation



- Ask participants what are the key attributes and role of an inline checker.
- Tell participants to complete the questions at the end of the sub unit.
- Ask participants if they have any doubts. Encourage them to ask questions.
- Answer their queries satisfactorily.

Suggestive Questions to ask students:

- Ask students to explain different parts of a Trouser.
- Ask students to list steps of stitching a saree blouse.

UNIT 3.3: Knowledge of Basic Embroidery Stitches

Unit Objectives

At the end of the unit, students will be able to:

1. Understand flat stitches, loop stitches and knotted stitches
2. Carry out flat stitches, loop stitches and knotted stitches

Resources to be Used

- Available objects such as a duster, pen, notebook etc.

Do

- Greet and welcome the participants to the next session of the program.
- Before starting the session ask them do they have any doubts pertaining to the previous unit.
- Capture their responses on board and share them wherever necessary.
- Tell them that they will learn about equipment readiness in this unit.

Say

- Tell the students about the flat stitches. Discuss that flat stitches are simple embroidery stitches in which individual stitches are made without crossing or looping the thread. These stitches are used to form broken or unbroken lines or starbursts, fill shapes and create geometric designs.

Elaborate

Commonly used types of Flat Stitches and their techniques are given below:

- Running Stitch
- Back Stitch
- Stem Stitch
- Satin Stitch
- Kashmiri Stitch
- Couching Stitch
- Cross Stitch
- Herringbone Stitch

Trainer's Note:

- These are supporting content to the Participant Manual, please adhere to the Participant Manual and Explain the trainees' the concept and explain the demonstration of the all the steps mentioned in the Participant manual, for example: Steps of Carrying out running stitch; Steps of Carrying out Back Stitch; Steps of Carrying out Back Stitch and etc.

Say 

- Tell the participants about loop stitch. Explain that loop stitch gets its name from the long loops it leaves behind. Commonly used types of Loop Stitches and their techniques are given below:
- Chain stitch
- Button-hole stitch
- Blanket Stitch
- Fishbone stitch
- Feather stitch
- Fly Stitch

Demonstrate 

The chain stitch is a looped stitch that can be worked along a curved or straight line. Variations of this stitch including the single or detached chain, lazy daisy, feathered chain, square chain, cable chain, heavy chain, zig-zag chain and many more. This stitch is commonly used for outlining, straight and curved lines, filling if rows are stitched closely together

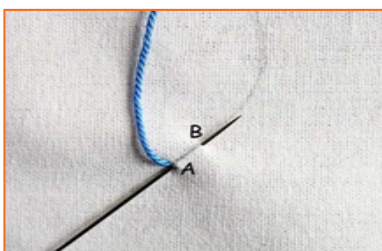

Step 1: Bring the thread out through A. Put the needle back in A and bring it out through the point B, but don't pull the needle out completely.

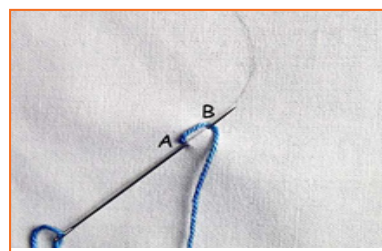

Step 2: Take the thread around the needle from left to right to form a loop

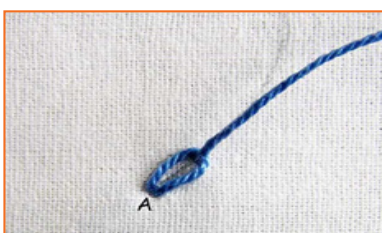

Step 3: Pull out the needle now to tighten the loop and you will get the first part of the chain.

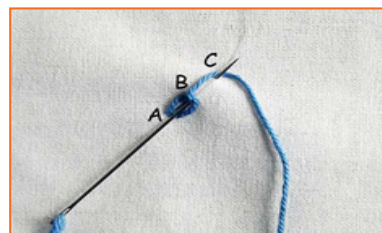

Step 4: Put the needle in through B (now inside the loop) and bring it out on C (outside of the loop).



Step 5: Continue the action by taking the thread around the back of the needle from left to right to form a loop and pull out the needle to get the next loop of the chain. Keep on with this procedure to finish the design.

Trainer's Note:

- These are supporting content to the Participant Manual, please adhere to the Participant Manual and Explain the trainees' the Demonstrate the concepts (For Example: Steps of Carrying Button Hole Stitch; Steps of Carrying out Blanket Hole Stitches).

Say 

- Tell them about the knotted stitch. Explain that a knotted stitch is any embroidery technique in which the yarn or thread is knotted around itself. Knotted edgings are used as a decorative trims, and can also be used to fill open spaces in cutwork and in needle-lace. Commonly used types of Loop Stitches and their techniques are given below:
 - » French Knot
 - » Double Knot
 - » Bullion Knot

Demonstrate

Steps of Carrying out French Knot

This is one of the most commonly used knotted stitches. French knot is used to make decorative dots, filling flower centres, leaves, plants etc.

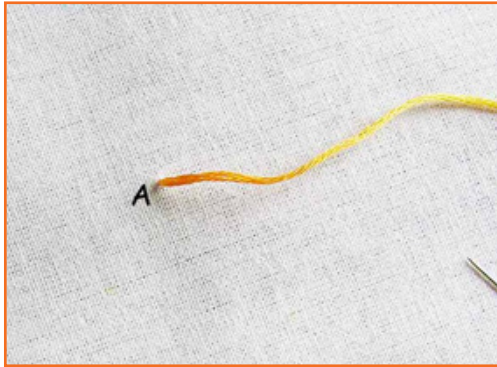

Step 1: Bring the needle out through A.

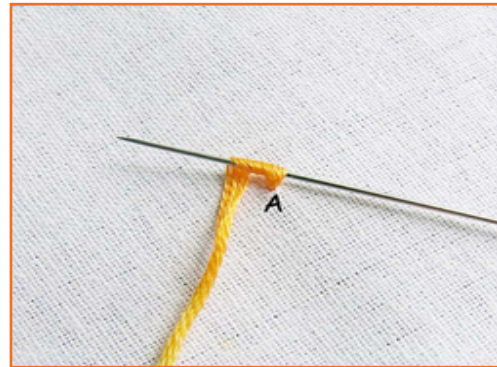

Step 2: Place the needle close to the fabric. Wrap the thread around it twice.

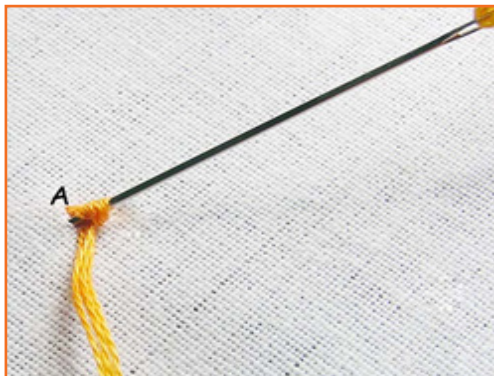

Step 3: Keep the longer end of the thread pulled with your fingers while putting the needle back in a point just close to A or even through A.

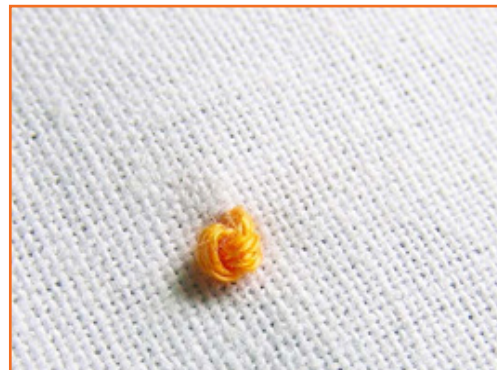

Step 4: Pull down the needle through the fabric. You will see your first French knot formed.

Steps of Carrying out Double Knot

It is also known as Palestrina knot stitch. This stitch is usually used for outlining or bordering purposes.

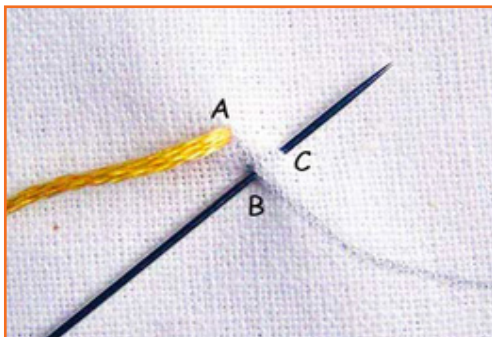

Step 1: Bring the needle out through the point A, which lies on the stitch line. Then, take the needle in through B, which lies on the stitch line too. Bring out the needle through C, a point straight above and not too far from B.

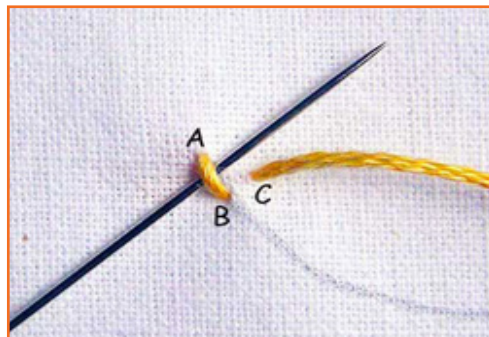

Step 2: Take the needle below the stitch A-B, without plucking the fabric underneath. The needle will be angled above or towards the left of the point C.

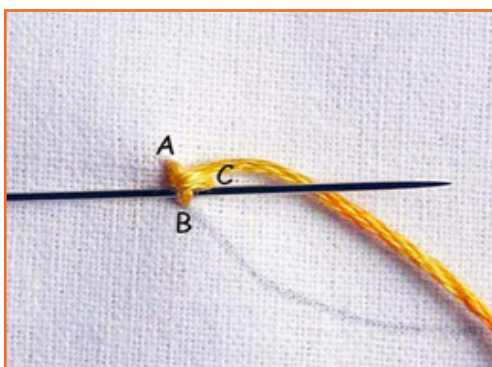

Step 3: Take the needle under the stitch A-B. Only, this time, the needle is angled below or towards the right side of the point C. Then, loop the thread around the needle

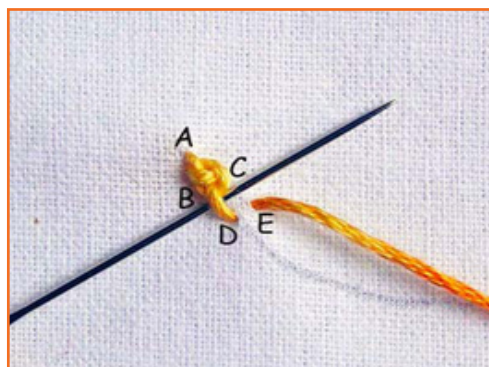

Step 4: When we pull out the needle, the first double knot is formed. For the next knot by putting in the needle through D on the stitch line and bringing it out from E, just above the point D. Continue with the procedure as we did for the first knot.



Step 5: The finished portion of double knot would look like as in figure.

Steps of Carrying out Bullion Knot

This knot is very similar to the French Knot, but here the loop is threaded around the needle more times, producing a worm of a knot that is inserted a slight distance from the needle's original entry point. Bullion knot is used to create decorative dots, leaves, plants etc.

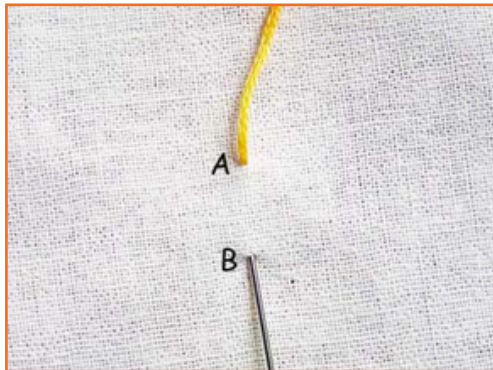

Step 1: Bring the needle out through A and put the needle through B at a desired length.

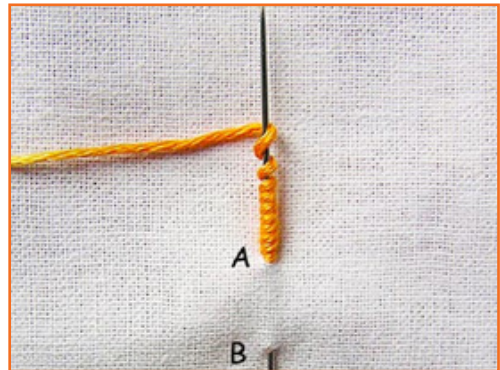

Step 2: Bring the needle out through A again. Then, wind the thread around the needle as shown. The distance of wound thread should measure the same as the distance between A and B. Too many or too less wraps will spoil the stitch.

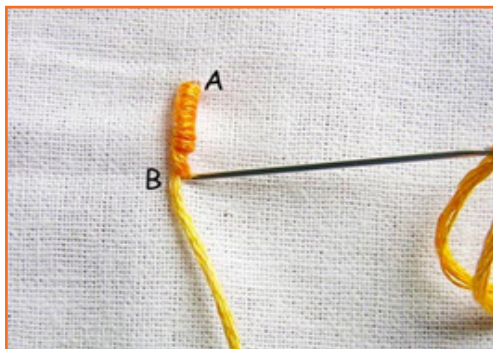

Step 3: Hold the wrapped thread with your fingers and pull the needle out with the other finger. Keep pulling the needle completely in an upward direction till the wraps lay on the fabric. Adjust and straighten the wraps if required and put in the needle back through B.



Step 4: The finished bullion stitch would look like as in the figure

Notes for Facilitation

- Ask participants what are the key attributes and role of an inline checker.
- Tell participants to complete the questions at the end of the sub unit.
- Ask participants if they have any doubts. Encourage them to ask questions.
- Answer their queries satisfactorily.

Suggestive Questions to ask students:

- Ask students to explain different types of flat stitches.
- Ask students to explain knotted stitch.



Skill India
वीरवार मरुत-कुषरत मरुत

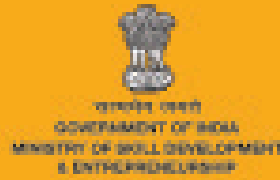

4. Inspections and Alterations of Garments for Fittings

Unit 4.1 - Inspections and Alterations of Garments for Fittings

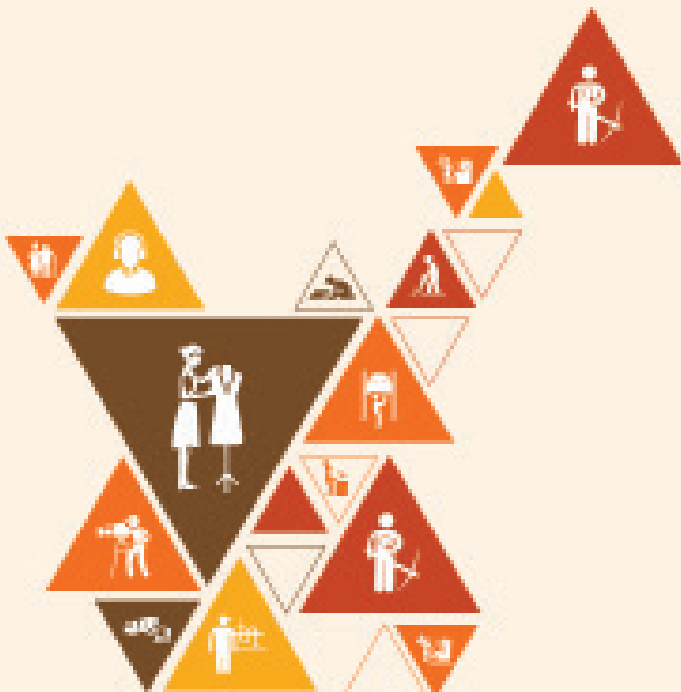

AMH/N1949

Key Learning Outcomes

At the end of the module, you will be able to:

1. Know the importance of basic elements of garment fitting
2. Carry out fitting inspection
3. Recognise the common fitting errors and their solutions

UNIT 4.1: Inspections and Alterations of Garments for Fittings

Unit Objectives

At the end of the unit, students will be able to:

1. Know the importance of basic elements of garment fitting
2. Carry out fitting inspection
3. Recognise the common fitting errors and their solutions

Resources to be Used

- Available objects such as a duster, pen, notebook etc.

Do

- Greet and welcome the participants to the next session of the program.
- Before starting the session ask them do they have any doubts pertaining to the previous unit.
- Capture their responses on board and share them wherever necessary.
- Tell them that they will learn about equipment readiness in this unit.

Say

- Tell the students about the Basic Elements of Garment Fitting. Explain that a good fitting garment is very important for customer satisfaction. Great attention to details has to be paid when a tailor does fittings. If the fittings are incorrect the look and design of the garment is destroyed.

Elaborate

A good fit is based on 5 classic elements

1. **Grain:** for a good fit the garment should be cut on the right grain. If the garment is off-grain, the seam lines may twist or hang crooked. Inaccurate cutting or stitching may result in deviation in the grain line.
2. **Set:** Is when the garment fits perfectly without any undesirable wrinkles. Wrinkles usually occur because the garment is too large or too small for the customer.
3. **Line:** Refers how the lines of the garment are in alignment with the natural lines of the body. Poor design or construction can result in an out of line garment.

Say

- Tell the participants how to inspect the fitting of the garments.

Elaborate

A tailor must check the following details when he checks the fittings of a garment

Shoulders

- Seam should lie on the edge of the shoulder.
- The shoulders should be wide enough to ensure that the sleeves hang comfortably into position.
- The shoulder slope of the garment should go in sync with the shoulder slope of the wearer.

Trainer's Note:

- These are supporting content to the Participant Manual, please adhere to the Participant Manual and Explain the trainees' the Demonstrate the concepts.

Say

- Tell the participants how to do the fitting of the garments.

Elaborate

To have a good fit of a garment, accurate calculations and design corrections is not enough. They can only provide an approximation of one's figure needs. The other points to be considered to have a good fit are:

1. The stylishness of the attire whether it suits oneself or not.
2. The sufficient ease in the garment.
3. The posture and the individual figure of the wearer.

Only on a fabric test fit, these can be evaluated. Since only minor changes can be made once the garment has been cut on the fabric. Hence a test fit can save lot of waste. There are times when test fit is not necessary, those are when one is sure of the style, know from experience how to adjust the pattern, have sufficient material to recut if necessary and have adequate seam allowances to borrow in crises. But if one has any doubts whatsoever, then test fitting is a must.

Usually used test material is muslin, bleached or unbleached. It should be used in a similar weight to that of the final fabric. Any other solid coloured plain weave fabric like poplin in a similar weight to final fabric would do. A plain surface is recommended as this clearly shows all seams, darts and other style details. Layout the pattern cut and mark your test fit fabric with equal amount of care as you would your final garment fabric. The fastest way to get the outcome of the finished garment without actual stitching is to overlay and pin all the seams lines. Pinning gives the same result and information, that one wants without going to the machine. It is so faster to unpin and then re-pin. After that to rip stitching and re-stitching.

Pins must be placed at the right angle to the seam line, as in, this method there is least amount of straining or pull on the seam, and it does not gape. When test-fitting trousers remember to baste stitch the crotch seam.

Check the test fit muslin and make alteration till fully satisfied. Mark all the rectifications and the same should be relocated on the pattern for it is the paper pattern that one should use to cut the final fabric and not the test fit muslin. Mark new notches as the old ones may not hold good after the alterations. Check the lengths of two corresponding seams to ensure that the alterations have not created more problems, e.g. if you have corrected the dart intake of side seam dart in the front, check to ensure that both the side seams are still equal or not and if vital make the necessary changes.

Methods of fit

There are two kinds of fitting:

1. The first test fit is done on muslin at the time when the design is made. A basic test fit is done to cross check, the pattern fitting; the pattern is cut with relevant seam allowances and pinned in place for test fitting. Make sure that seams and darts are in place. This fitting is done from the right side of the garment. These corrections become the new seam lines for the garment. Check the garment for ease and fullness. It is important to mark buttons and buttonholes at right places in this fit.
2. The second is after the garment has been stitched before final finishing. Stitch the garment with relevant interfacing/ or underlining in place press it well and test fit to check the position of darts, seams, puckers if any and locate the position of outer seams. This type of fitting refines and perfects the fit of the garment. Other times when refitting becomes necessary are if the garment has been purchased readymade from the market some alterations may be required for it to be fitted to an individuals size and also if there are changes in the body size, like if some one has grown thin or has put on weight or if a child has gained height.

Say

- Discuss the common fitting errors and their solutions with the participants.

Elaborate

Most of fitting errors can be altered or changed easily.

Problems	Solutions
Folds below the bust dart	Undo the dart and part of the side seam. Lift shoulder a little, re-pin a bigger dart and pin the side seam to take out the excess fabric.
Gaping armhole	Undo dart and pin a bigger dart. Making sure that it points towards the bust point. One may need to lift shoulder seam at the armhole.
Low neckline gapes.	Lift at the front shoulder seam. Lower the dart point if necessary.
Folds in the dress below the waist.	Undo the side seam from below the armhole and ease out until the garment hangs smoothly.
Tight neck or armhole.	Slash and snip seam allowance to release tension
Neckline stands away and folds below.	Release shoulder seam and let it out at the armhole edge.

Shoulder seam lies towards the front of the shoulder.	Undo shoulder seam and release front seam allowances only.
Sleeve hangs towards the back	Remove the sleeve and re-pin by moving the notch at the centre of the sleeve toward the back so that the sleeve may hang towards the front.
Wrinkles and creases around the upper arm.	Release the underarm seam allowance and add the ease.
Sleeve pulls at the back armhole.	Unpin the sleeve and release the seam allowance on both the armholes of sleeve and bodice.
Trousers are loose at waist, hip or leg. Creases on leg and trousers stands away at waist.	Take excess fabric at side and pin at original seam lower down. For larger hip increase the dart intake. Pin the excess towards the outer seam.
Trousers tight below the waist, crease around abdomen.	Release darts and reduce their width and length, also release some ease on the outer seams and re-pin.

Fig.4.1.20: Common Fitting Errors and Their Solutions

Notes for Facilitation

- Ask participants what are the key attributes and role of an inline checker.
- Tell participants to complete the questions at the end of the sub unit.
- Ask participants if they have any doubts. Encourage them to ask questions.
- Answer their queries satisfactorily.

Suggestive Questions to ask students:

- Ask students to explain basic elements of garment fitting.
- Ask students to explain methods of fit.



Skill India
वीरता सशक्त - कुशल भारत

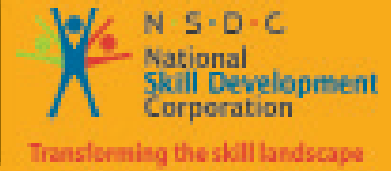
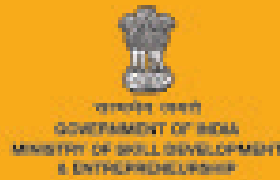

5. Maintain Work Area, Tools and Machines

Unit 5.1 - Maintain Work Area, Tools and Machines

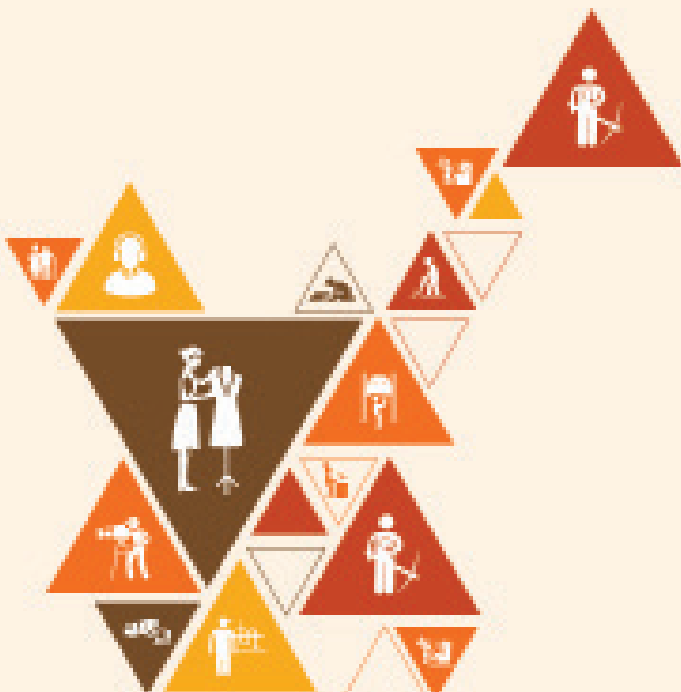

AMH/N0102

Key Learning Outcomes

At the end of this module, you will be able to:

1. Practice the machine safety and maintain machines properly.
2. Carry out basic maintenance of machine.
3. Maintain tools and equipments and handle them safely.
4. Use materials to minimize waste.
5. Carryout running maintenance within agreed schedules.
6. Carry out maintenance and/or cleaning within one's responsibility.
7. Work in a comfortable position with the correct posture.
8. Use cleaning equipment and methods appropriate for the work to be carried out.
9. Dispose of waste safely in the designated location.
10. Store cleaning equipment safely after use.
11. Carryout cleaning according to schedules and limits of responsibility.

UNIT: 5.1 Maintain Work Area, Tools and Machines

Unit Objectives

At the end of this unit, the students should be able to:

1. Practice the machine safety and maintain machines properly.
2. Carry out basic maintenance of machine.
3. Maintain tools and equipments and handle them safely.
4. Use materials to minimize waste.
5. Carryout running maintenance within agreed schedules.
6. Carry out maintenance and/or cleaning within one's responsibility.
7. Work in a comfortable position with the correct posture.
8. Use cleaning equipment and methods appropriate for the work to be carried out.
9. Dispose of waste safely in the designated location.
10. Store cleaning equipment safely after use.
11. Carryout cleaning according to schedules and limits of responsibility.

Resources to be Used

- Available objects such as black or white Board, chalk pieces or white board marker pens, duster
- PC with LCD Projector or Flip Chart
- Copies of handouts, Participants Handbook

Do

- Greet and welcome the participants to the next session of the program.
- Before starting the session ask them do they have any doubts pertaining to the previous unit.
- Capture their responses on board and share them wherever necessary.
- Tell them that they will learn about Finishing Department Workflow

Say

- Machines are essential to modern production. However, along with increased productivity, they have brought hazards into the workplace. Proper control of machine hazards has traditionally been seen as costly and a constraint on productivity. In general, the garment manufacturing industry is considered to be less dangerous than other industrial sectors and, therefore, safety policy is a low priority in many enterprises. For example, it has been observed that some workers remove guards protecting belts from sewing machines and manual cutting machines are operated with naked hands.

Do

- Teach the students about the techniques of maintaining machines.
- Make them learn how to clean the Bobbin area.
- Explain the steps of cleaning the feed dog assembly.
- Explain the steps of lubricating the machine and also make them understand the functions of the machine guards.
- The basic steps of maintain the machine should be thoroughly demonstrated to them.
- Lastly, it is extremely essential to make them understand the safety tips that are common towards using and handling the machine.

Demonstrate

Cleaning the Bobbin Area

- **Step 1:** Turn off and unplug the sewing machine.
- **Step 2:** Remove the bobbin cover and the bobbin.
- **Step 3:** Using a small lint brush (many machines come with one), carefully remove any lint from the bobbin area. Be especially sure to remove any lint from crevices and tight places, since compacted lint can actually stop the machine from running.
- **Step 4:** Using the lint brush or canned air, remove the lint from the area around the needle, the presser foot and the thread guides.
- **Step 5:** Remove any lint from the inside of the doors and lids of the sewing machine.
- **Step 6:** Replace the bobbin and the bobbin cover.
- **Step 7:** Plug the sewing machine back in and turn it on.

Note: Make sure to check that after cleaning all the machine parts are properly placed and tightened. It should be safe for using it the next time.

Trainer's Note:

- These are supporting content to the Participant Manual, please adhere to the Participant Manual and Explain the trainees' the concept.

Elaborate **Machine Guard**

There are different safety guards given in the sewing machine which are important to use and it is also essential to check that the correct safety guard is in place as per the requirement. Below are given the machine guards of a sewing machine.

- Finger guard
- Eye guard
- Belt guard
- Motor pulley guard

Troubleshoot Common Machine

In several cases machine issues are due to the employee not having received correct training in basic machine maintenance. This causes issues that need to be corrected by a certified mechanic/technician. All garment enterprises suffer from such issues to varying degrees. Some common causes are¹⁸²:

- Incorrect needles
- Incorrect machine settings for the fabric
- Inexperienced workers
- Inexperienced mechanics/technicians
- Fabric finishes.

On-the-job training sessions could also be organized for beginners as part of their training period. Enlist the assistance of senior operators with teaching skills. group work will provide good opportunities for these training sessions. Sessions ought to embrace acquiring the essential sewing skills and troubleshooting sewing issues.

Carry out Basic Maintenance of Machine

It is important to carryout basic maintenance of own machine and surroundings. While operating a sewing machine we can keep a check of these two maintenances by keeping an eye on the needle point i.e.

- Must check the needle point and stitch quality while working. Be attentive and look for any kind of oil leakage is found, replace (or inform) immediately. For hazard free environment always keep the hook area clean and tidy.
- **Routine Maintenance:** This covers sub kinds of maintenance i.e.
 - » Daily maintenance of the machinery
 - » Weekly maintenance
 - » Monthly maintenance

Activity

In the industry visit:

- Make the students show you about the maintenance techniques.
- Ask them to clean and dispose wastes
- Ask them to demonstrate them the store cleaning equipments.

Notes for Facilitation

- Summarize the main points.
- Ask participants if they have any doubts.
- Encourage them to ask questions.
- Answer their queries satisfactorily.
- Tell participants to complete the questions at the end of the unit.
- Ensure that every participant answer all the questions.

Suggestive Questions to ask students:

- Ask students to list the steps to clean the Bobbin area.
- Ask students to list the steps to clean the Feed Dog Assembly.



Skill India
वीरता माना - कुशल माना

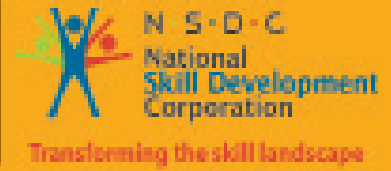

6. Comply with Industry, Regulatory and Organizational Requirements

Unit 6.1 - Comply with Industry, Regulatory and Organizational Requirements

Unit 6.2 - Entrepreneurship

Unit 6.3 - Documentation

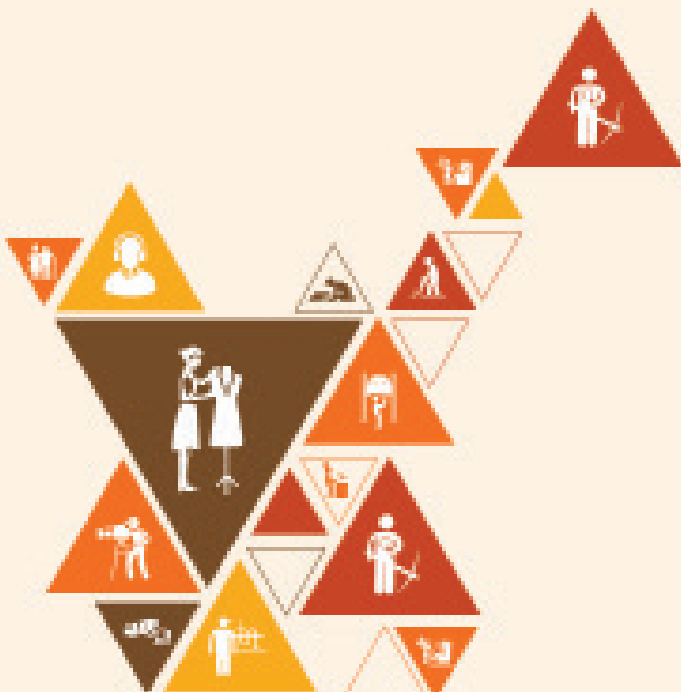

AMH/N0104

Key Learning Outcomes

At the end of this module, you will be able to:

1. Carryout work functions in accordance with legislation and regulations, organizational guidelines and procedures.
2. Seek and obtain clarifications on policies and procedures, from your supervisor or other authorized personnel.
3. Apply and follow these policies and procedures within your work practices.
4. Provide support to your supervisor and team members in enforcing these considerations.
5. Identify and report any possible deviation to these requirements.

UNIT: 6.1 Comply with Industry, Regulatory and Organizational Requirements

Unit Objectives

At the end of this unit, the students should be able to:

1. Carryout work functions in accordance with legislation and regulations, organizational guidelines and procedures.
2. Seek and obtain clarifications on policies and procedures, from your supervisor or other authorized personnel.
3. Apply and follow these policies and procedures within your work practices.
4. Provide support to your supervisor and team members in enforcing these considerations.
5. Identify and report any possible deviation to these requirements.

Resources to be Used

- Available objects such as black or white Board, chalk pieces or white board marker pens, duster
- PC with LCD Projector or Flip Chart
- Copies of handouts, Participants Handbook

Do

- Greet and welcome the participants to the next session of the program.
- Before starting the session ask them do they have any doubts pertaining to the previous unit.
- Capture their responses on board and share them wherever necessary.
- Tell them that they will learn about Finishing Department Workflow

Say

- The clear and crisp definition of compliance.
- Explain the significance of compliance in Indian Garment Industry.
- Enlighten them about the core labor standards of India.

- Explain the role played by AEPC in the Garment Industry in India.
- Talk about the social responsibility towards this end.
- State the labour laws and tell them about their rights, compensations and duties.
- State the common compliance code.
- Health and safety compliance should be explained.
- State the codes of practices which are needed to be noted.

Elaborate

Defining Compliance for Your Organization

According to *Merriam Webster* the dictionary definition of compliance is as follows:

1. The act or process of complying to a desire, demand, proposal, or regimen, or to coercion.
2. Conformity in fulfilling official requirements.
3. A disposition to yield to others.
4. The ability of an object to yield elastically when a force is applied.

Trainer's Note:

- These are supporting content to the Participant Manual, please adhere to the Participant Manual and Explain the trainees' the concept.

Notes for Facilitation

- Summarize the main points.
- Ask participants if they have any doubts.
- Encourage them to ask questions.
- Answer their queries satisfactorily.
- Tell participants to complete the questions at the end of the unit.
- Ensure that every participant answer all the questions.

Suggestive Questions to ask students:

- Ask students to explain the significance of Compliance in Indian Garment Industry.
- Ask students to explain International Labour Standards.

UNIT 6.2: Entrepreneurship

Unit Objectives

At the end of this unit, the students should be able to:

1. Understand importance of being an entrepreneur
2. Understand concepts of tailor shop economics like book keeping, inventory management

Resources to be Used

- Available objects such as black or white Board, chalk pieces or white board marker pens, duster
- PC with LCD Projector or Flip Chart
- Copies of handouts, Participants Handbook

Do

- Greet and welcome the participants to the next session of the program.
- Before starting the session ask them do they have any doubts pertaining to the previous unit.
- Capture their responses on board and share them wherever necessary.
- Tell them that they will learn about Finishing Department Workflow

Say

- Define and Explain the entrepreneurship.
- Why the accounting is done.
- Tell the participants about the client management.

Elaborate

Entrepreneurship

An entrepreneur is a person who runs his/her own business. Entrepreneurs are the ones who explore opportunities, scan the environment, mobilize resources, convert ideas into viable business proposition

and provide new products and services to the society by bringing together and combining various factors of production. An entrepreneurial individual has a distinct concept, vision and a dream, which he/she is able to convert into products. Such individuals are driven by task, challenge and opportunity with very high achievement orientation.

Notes for Facilitation

- Summarize the main points.
- Ask participants if they have any doubts.
- Encourage them to ask questions.
- Answer their queries satisfactorily.
- Tell participants to complete the questions at the end of the unit.
- Ensure that every participant answer all the questions.

Suggestive Questions to ask students:

- Ask students to define Entrepreneurship.
- Ask students to explain the importance of Accounting.

UNIT 6.3: Documentation

Unit Objectives

At the end of this unit, the students should be able to:

1. Understand importance of being an entrepreneur
2. Understand concepts of tailor shop economics like book keeping, inventory management

Resources to be Used

- Available objects such as black or white Board, chalk pieces or white board marker pens, duster
- PC with LCD Projector or Flip Chart
- Copies of handouts, Participants Handbook

Do

- Greet and welcome the participants to the next session of the program.
- Before starting the session ask them do they have any doubts pertaining to the previous unit.
- Capture their responses on board and share them wherever necessary.
- Tell them that they will learn about Finishing Department Workflow

Say

- Tell the participants that documentation is one the most crucial aspect of every job. By completing documents it is ensured that details of every transaction/event/incident are recorded and can be accessed when required.
- Due to limitations of human memory, it is very difficult to remember each transaction and its details. In order to keep a record of all the transactions, routine or special, tailor maintains and updates different types of registers. The importance of this information varies with time and situation. Some information is casual and day to day observation, while others are unusual and spontaneous. Due to limitations of human memory, a tailor's recall capacity is limited. Important events/incidents can be recalled with accuracy if some writing exercise is carried out and notes are made.

Elaborate

Maintaining Registers

The need for maintaining registers is explained below:

- To keep a record of transactions carried out
- To maintain order and uniformity in recording details
- A register is a documentary proof of a transaction carried out
- Gives a consolidated summary of a particular kind of transaction in a given period
- Can be used as a legal document
- Details of a past event can be retrieved whenever required
- To provide statistics of daily/monthly movement of men/material
- To maintain proper records of an incident on a day for future reference

According to the requirement, the tailor can use some registers. Commonly used registers are:

- Handing/Taking over Register
- Visitor Register (In/Out Register)
- Measurement Register
- Material Register

While maintaining a register a tailor should always remember the following key aspects:

- Register is to be named and all the pages are to be numbered
- Register is to be kept in good condition
- Pages of registers not to be torn or detached
- Use only blue/black pen while making entries
- Avoid corrections/overwriting
- Do not relocate the register from its designated post
- One dedicated register to be maintained for a particular purpose
- First entry of the day to be made on the current date
- All the fields of a particular entry are to be filled.
- Do not keep fields incomplete

Register Formats - Attendance Register

MATERIAL ISSUE REGISTER										
Date	Department Name	Receiver Name	Material Name	Qty	Unit	Material Issue slip No.	Remark	Material Receiver Signature	Store keeper Signature	

Fig.6.3.1: Material Register

VISITOR LOG BOOK												
Format No:												
SR NO	VISIT NO	DATE	NAME OF PERSON	VISITOR FROM	MEETING WITH	REASON FOR VISIT	LAST VISITED ON DATE	TIME		TIME SPENT		ACTIVITIES DONE DURING STAY
								IN	OUT	HOURS	MINUTES	

Fig.6.3.2: Visitor log (In/Out Register)

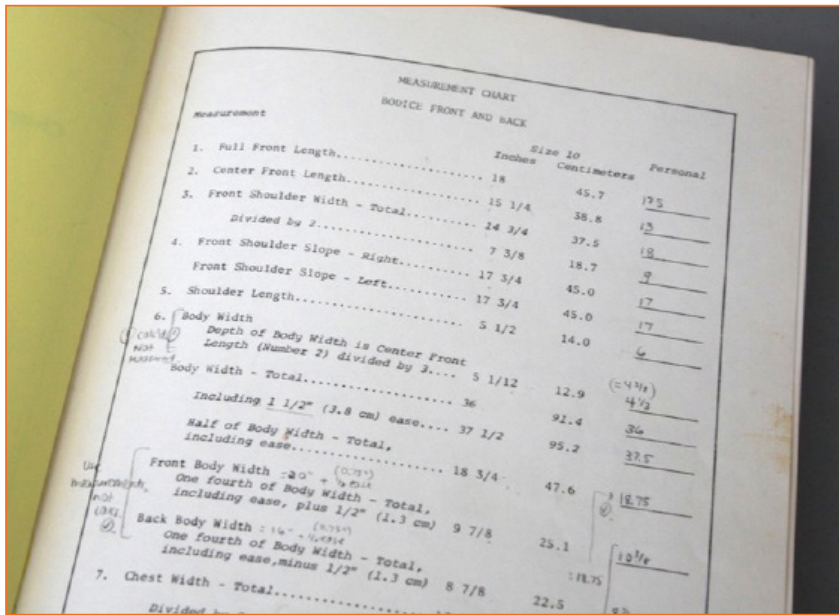

Fig.6.3.3: Measurement Register

Cost Sheet

A statement which provides for the assembly of the detailed cost of a centre or a cost unit. It is also a periodical statement.

A cost sheet is prepared to know the outcome and breakup of costs for a particular accounting period. Columnar form is most popular. Although cost sheets are prepared as per the requirements of the management, the information to be incorporated in a cost sheet should comprise of cost per unit and the total cost for the current period along with the cost per unit and the total cost of preceding period. Data of financial statement is used for preparation of cost sheet. Therefore, reconciliation of cost sheet and financial statement should be done on a regular interval.

The expenditure which has been incurred upon product for a period is extracted from the financial books and the store records and set out in a memorandum statement. If this statement is confined to the disclosure of the costs of units produced dividing the period, it is termed as Cost- Sheet, but where the statement records both total cost, profit and sales, it is usually known as Statement of Cost or Production Account.

Cost Sheet				
Date	12-03-2016	Description	Kameez with waist band	
Size	M	Colour	Blue	
Selling Price	Rs 758			
1. Material	Meters	Price	Amount	
Cotton	4	Rs 65/meter	Rs 260	
Lining	-	-	-	
Total Material Cost (1)				Rs 260
2. Trimmings and Accessories	Quantity	Price	Amount	
Buttons	4	Rs 0.5/button	Rs 2	
Pads				
Zippers				
Waist Band	1	10	10	
Elastic				
Total Trimmings and Accessories Cost (2)				Rs 12
3. Labour				
Cutting			Rs 20	
Sewing			Rs 250	

Total Labour Cost (3)				Rs 270
Total Cost (1+2+3)				Rs 542
Markup (profit)	@40 %			Rs 758

Fig.6.3.4: A typical cost sheet





Skill India
वीरवार भावत - कुशल भावत

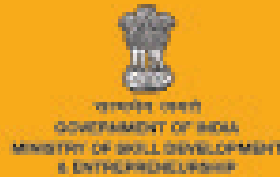

7. Soft Skills And Communication Skills

Unit 7.1 - Introduction to the Soft Skills

Unit 7.2 - Effective Communication

Unit 7.3 - Grooming and Hygiene

Unit 7.4 - Interpersonal Skill Development

Unit 7.5 - Social Interaction

Unit 7.6 - Group Interaction

Unit 7.7 - Time Management

Unit 7.8 - Resume Preparation

Unit 7.9 - Interview Preparation

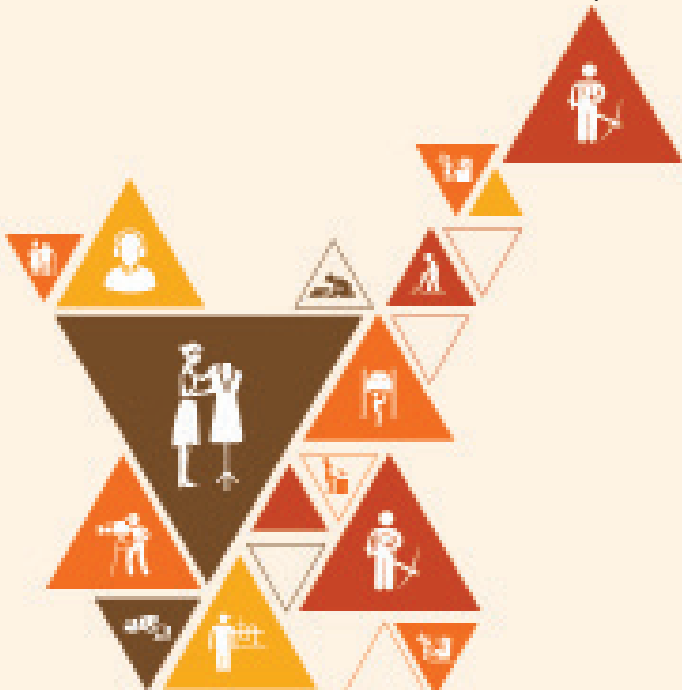

Key Learning Outcomes

At the end of this module, you will be able to:

1. Familiarise with the art of Effective Communication.
2. Able to handle effective Communication with co-workers and their Family.
3. Able to handle effective Communication with Peers/ colleagues using medical terminology in communication.
4. Maintain health and hygiene
5. Develop interpersonal skills
6. Develop effective social interaction
7. Manage time effectively
8. Prepare for interviews

UNIT 7.1: Introduction to the Soft Skills

Unit Objectives

At the end of the unit, students will be able to:

1. Describe the basic meaning of Soft Skills, their components and their benefits.
2. Familiarise with work readiness and its significance.

Resources to be Used

- Available objects such as black or white Board, chalk pieces or white board marker pens, duster
- PC with LCD Projector or Flip Chart
- Participant Manual

Say

- Employees are a crucial part of an organization, understanding them personally can be helpful in various aspects. There is much more to their identity than merely their skills. This brings into light, the concept of 'soft skills'.
- Soft skills are personal attributes that describes an individual's ability to interact with others. It includes the cluster of personality traits, social graces, communication language, personal habits, friendliness and optimism that characterize relationship with other people.
- Soft skills have more to do with who we are than what we know.
- Soft Skills complement hard skills which are occupational requirements of a job and many other activities.
- According to a survey, the long term success in job is 75 % due to soft skills and 25 % due to technical knowhow.

Activity

- Ask the students to form a circle.
- Starting from a one person, ask each of them to tell something about themselves. This should necessarily include their strengths and weaknesses.
- This will give them a better chance of knowing each other.

Explain

- Discuss what helps in keeping you happy in your school- academic knowledge or company of friends.

Say

- **Adaptability:** It is the ability of an individual to manage change. It's about how fast and smoothly a person is able to blend in and be productive in a changed environment.
- **Emotional Strength:** This involves managing mood and having control over it. An emotionally strong person succeeds in directing his moods and emotions such as anger frustration and excitement.
- **Leadership Quality:** How one manages conflict in personal and professional situation and convinces people reflects upon his leadership quality.
- **Team Playing Ability:** It is the ability to manage different types of people and make them work harmoniously with each other.
- **Decision Making:** This reflects upon how one manages his time and other resources in efficient and productive manner.
- **Interpersonal Communication:** This is an individual's ability to effective communication with other and in the process creating a positive image of him.
- **Negotiation Skills:** This is how one negotiates with others and reduces the level of stress in work, professional and personal environment.

Activity

- Ask students to sit in a circle.
- Blindfold a student and give him a packet of biscuit.
- Ask the other students to come one by one and ask for the packet and make attempt to convince him as to why he should be given the packet.
- The blindfolded person has the authority to refuse to give to the people who fail to convince him and give it only to the person who succeeds in convincing him.
- At the end of the game we would be able to have an insight as to which person possesses the best communication skills, negotiation skills, etc.

Explain

- On the basis of the activity, discuss what corrective steps could the other people take to improve their communication/negotiation skills.

Say

A person who interacts well with others gets added advantages other than personal satisfaction. Also, personal traits like decision making, leadership ability are not only related to the concerned person himself but they affect others to whom the person interacts. Some of these benefits include :

- Increased credibility with customers
- Increased customer satisfaction
- More productive employees
- Recognition from the industry, employer and peers.

In short, they aid in the personal growth of a person.

Activity

- Ask the students to sit separately.
- Ask them to write whether they buy grocery products from one shop daily or prefer to go to any shop selling such products.
- If they go to one shop, ask them to give reason for their loyalty. Is it the good behavior of the shopkeeper that keeps them loyal?
- Also, ask the people who do not have any such preference, reasons for this behaviour.

Say

Work readiness involves you having what employers call “the right attitude”. At the most basic level you should have:

- A positive attitude to spend some days at tailoring shop
- The capacity to function in a mature environment without the support of other co-workers
- An allegro attitude to the owner
- A clear interest at work to be done
- Expectations of the work that a fresher will be able to do at a tailoring shop with commercial goals to achieve
- The willingness to be supervised, follow instructions and wear safety gear as directed
- The confidence to ask questions to clarify instructions
- Pride in appropriate personal presentation
- The ability to communicate appropriately in an adult working environment
- The capacity to acknowledge customers and provide the assistance recommended by the employer
- A commitment to maintaining their reliability and punctuality for the whole of the period spent in the tailoring shop

- Completed a preparation for tailoring shop learning program which includes OH&S practices, acceptable behaviour in the tailoring shop (including child protection issues) and emergency contact procedures.



Fig.7.1.1: Work Readiness

Activity

- Ask the students to form a group.
- Ask them about their interest- painting, dancing, etc. people might come up with different interests.
- Based on it, ask the entire group to do an activity say painting.
- Observation can show that people who like doing a particular task say painting are likely to show more zeal than others who do not have much interest in it.
- Also, such people are more likely to have an active participation throughout the activity and enjoy it rather than taking it as a burden.

Explain

- Based on the results, discuss why some student's/ groups were able to get better results. This could be due to difference of interests, enthusiasm, confidence, etc.

Notes for Facilitation

Suggestive Questions to ask students:

- Ask students to define soft skills
- Ask students to list Benefits of soft skills

UNIT 7.2: Effective Communication

Unit Objectives

At the end of the unit, students will be able to:

1. Do public speaking.
2. Describe his /her likes and dislikes for five minutes in the classroom.
3. Basic etiquette during a conversation with another person, overcome shyness etc.

Resources to be Used

- Available objects such as black or white Board, chalk pieces or white board marker pens, duster
- PC with LCD Projector or Flip Chart
- Participant Manual

Say

- Communication is a tool that connects us with other human beings. An effective communication not only helps in developing a sense of belonging but also facilitates better working, improves relationships, reduces stress.

Say

- Communication is the process of exchange of words, ideas, feelings. It is the meaningful exchange of information between two or more participants.
- Communication requires a sender, a message, a medium and a recipient.
- Communication process is complete only when a receiver understands the sender message.

Elements Of Communication

Communication with other involves three steps:

1. **Message:** First of all the information exists in sender's mind. It could be a concept, an idea, a formation or a feeling.
2. **Encoding:** A message is sent to the receiver in encoded language/format.
3. **Decoding:** Lastly the receiver translates the words or symbols into a concept or information that a person can understand.

The Communication Process

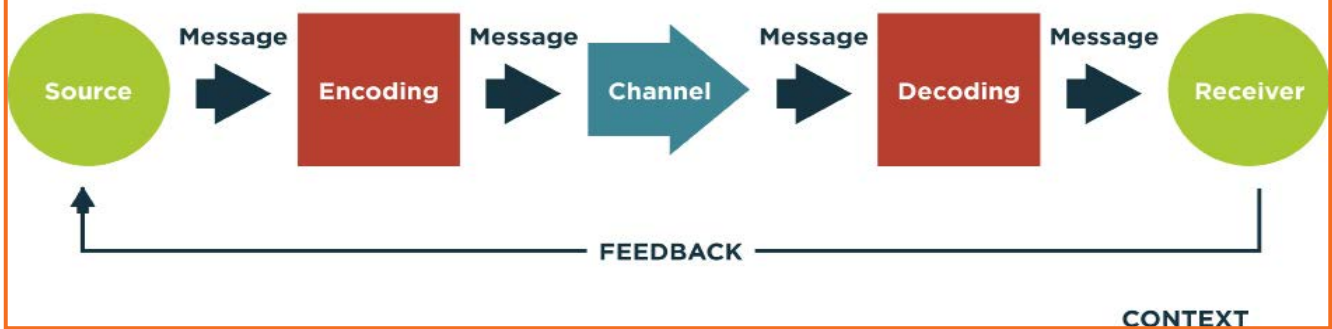

Fig.7.2.1: Communication Process

Activity

- Call 2 students.
- Ask them to have a casual conversation.
- With respect to their conversation, explain who is the speaker, what is the message.
- Also explain encoding, decoding and feedback with respect to the conversation.

Explain

- Discuss the importance of tone of voice, gestures, etc. in a communication process.

Say

There are three main types of communication. These are:

1. **Verbal Communication:** It means you listen to a person to understand what message the person is trying to convey. The speaker have the advantage of immediate feedback. This type of communication is best for conveying emotions and can involve storytelling and critical conversations.
2. **Written Communication:** Letters, books, newspapers are few of the examples of written communication. Printed media, emails can also be categorised into this communication. They are asynchronous, can reach many readers and are best for conveying information.
3. **Nonverbal Communication:** A nonverbal communication can also be called Body language because this communication does not involved any verbal interaction but mere observation of the people involved in the communication. Both verbal and written communications convey nonverbal communication and are also supported by body language, eye contact, facial expression, posture, touch and space

According to a study only 7% of a receiver's comprehension of a message is based on sender's actual words, 38% is based on paralanguage (tone, pace and volume of speech) and 55% is based on nonverbal cues.

Activity

- Ask 2 students to explain the process of communication.
- Pay attention to the way they explain.
- Categorize the various types of communication used by them.

Explain

- Discuss the situations in which each of them is used.

Say

- There are various reasons why communication is not effective and successful. These failures are because of the barriers in communication which occurs at any stage in the communication process. Barriers may lead to one's message becoming misleading and therefore at risk of wasting both time and money by causing confusion and misunderstanding. Effective communication involves overcoming these barriers and conveying a flawless and concise message:
- Some of the barriers can be overcome- using simple language, active listening can be of great help.

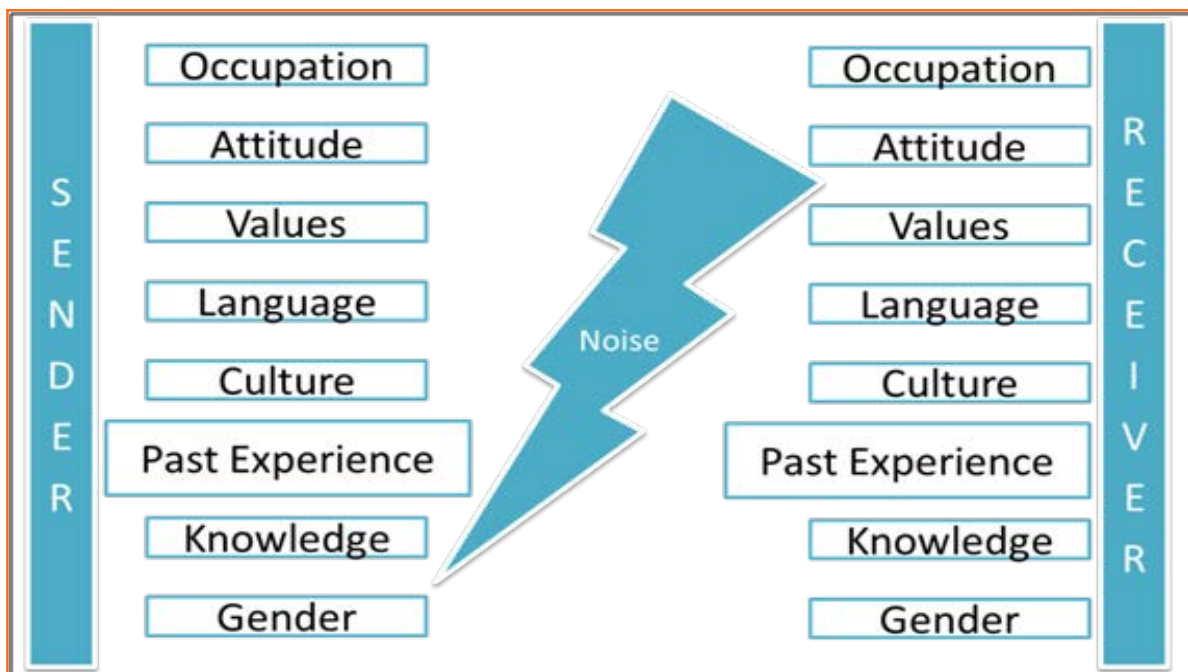

Fig.7.2.2: Communication

Activity

- Organize students into groups of 2.
- Give one of the students, an article about a totally unknown topic.
- Give him 10mins. Time to read it.
- Let him explain to the class by the end of the time, what is the topic all about and crucial details in it.
- Ask the students what they have understood.
- Discuss about problems in understanding (if any) faced by the rest of students.

Explain

- On the basis of the activity above, discuss the barriers in communication.
- Also, discuss how these barriers can be taken care of.

Say

Active Listening

- Listening is one of the most significant skills one can have. To become a better listener it is important that you practice active listening at all time of verbal communication.

Activity

- Call 3 students.
- Give a student a written piece. Ask him to read it out loudly to the other 2 students.
- Provide one student with earphones to listen to music while listening to the information.
- Let the other person listen to it without any distraction.
- At the end of the reading, ask both the student to tell what has been read out.
- As a matter of fact we would find out that the person who has put all his attention in listening would yield better results in comparison to the other one.

Say

- Concentrate what the person is talking about and not on noise or other external distractions.
- Understand his emotions and you get it all right. Is the speaker angry, happy or plainly inquisitive?
- When the speaker is saying or telling something, don't break the chain of his thoughts.
- Don't avoid completing sentences of the speaker. Let them speak and speak only after they finish.

Activity

- Ask the students to sit forming a circle.
- A student to start saying counting, the next one should follow saying the consecutive number.
- At the gap of multiples of 5, the respective student is expected to clap instead of saying the number.
- The student who fails to do this, would be disqualified for the game. The others would proceed.
- At the end the one who wins the game would be considered the best listener.

Explain

- Discuss with the students the importance of being an active speaker in a debate where counter-questioning is allowed.

Notes for Facilitation

Suggestive Questions to ask students:

- Ask students to explain elements of communication.
- Ask students to explain the importance of active listening.

UNIT 7.3: Grooming and Hygiene

Unit Objectives

At the end of the unit, students will be able to:

1. Maintain cleanliness and hygiene.
2. Keep their dress clean and tidy.
3. Maintain positive body language while speaking.
4. Enable to perform more of the do's than the don'ts.
5. Leant about good eating habit and their impact on health.
6. Avoiding bad things such as gutkha and alcohol.
7. Learn about AIDS and its prevention.

Resources to be Used

- Available objects such as black or white Board, chalk pieces or white board marker pens, duster
- PC with LCD Projector or Flip Chart
- Participant Manual

Say

- An art of keeping your body and mind clean is Personal Grooming. It is very important that everyone should take care of their hygiene cleanliness. Due to this, one would not just look good but feel healthy to. Taking care of your body appearance is imperative. Once you enter your store/department you need to be dressed in full uniform as per company standards, and also properly groom yourself as per the service ethics.
- Personal grooming not only makes us presentable but also makes us feel confident about ourselves. Good personal hygiene is essential for good health. Habits that are considered personal grooming include, bathing, dressing, applying makeup, hair removal and taking care of one's teeth, nails and skin.

Say

There are certain norms as to how one should dress in a work arena. A decent appearance should be maintained. This includes:

- Neat and ironed uniform
- A decent hairstyle should be adopted. Women with long hair should tie them.
- Nails should be neat, clean and well-trimmed.
- Flashy and noisy jewellery should be avoided.

Activity

- Ask the students to write about why one's uniform should be neat, clean and ironed.

Explain

- Ask the students to discuss the importance of uniform in school.
- Also ask them to discuss about incidents when they formed an opinion about others based on their dress.

Say

- Staff needs to keep their hands clean at all times as they mostly will be handling merchandise or in contact with customers.
- Avoid biting nails on the floor.
- Manage body odour & bad breath to be under control as they are offensive to the customer.
- Maintain straight & upright posture on the shop floor.
- Slouching on the floor, hands in pockets, hands on the hips are not courteous to the customer & hence should be avoided.

It just takes a few seconds for people to assess others when they meet for the first time. The other person creates an opinion based on appearance, body language, mannerisms and how one is dressed. For creating a first positive good impression always follow these things:

- Apart from a good body posture, a person should
 - » Be on time
 - » Be courteous and attentive
 - » Be positive

Explain

- Why are students advised to keep their hands at the back while talking to a teacher or while walking in a line?

Say

- Body language plays a great role in conveying about a person. A positive body language is very important for conveying information positively. Certain do's and don't's in this regard are as follows:

- » Avoid your pockets. Keep your hands out of your pocket. Hand in pocket shows we are uncomfortable and unsure of ourselves. Keeping our hand in open indicates confidence and show that people has nothing to hide.
- » Don't Fidget. Fidgeting is a clear sign of nervousness. An individual who can't keep still is an individual who is worried, tense and not confident. Keep your gesture calm and under control.
- » Keep your eyes forward. This indicates that you are interested in communication with other.
- » Stand up straight with your shoulders back. It communicates confidence.
- » Take wide steps. It makes you seem purposeful and suggest a personal tranquillity and denotes confidence.
- » Firm handshake. Grip other persons hand firmly and confidently instead of getting a palm full of dead fish. Firmness adds warmth and enthusiasm to the handshake. But make sure that you don't crush the other person's hand and don't hold on too long.
- » Don't cross your arms when meeting other persons. Crossing your arms is a protective posture. Relax and keep your arms uncrossed.
- » Use contact to show appreciation.

Activity

- Call 5-7 students. Ask them to enact different gestures like- one is told to stand up straight, other is told to enact the movements of shaky hands.
- Ask the rest of the class to judge the body language and the possible implications it could have on the viewer.

Explain

- Why is so much attention laid at school level on making children stand straight?

Say

- Personal Hygiene is the set of practices to follow to preserve one's health. Maintaining a high level of personal hygiene will help to increase self-esteem while minimizing the chances of developing infections. Poor personal hygiene can have significant implications on the success of job applications or chances of the promotion.

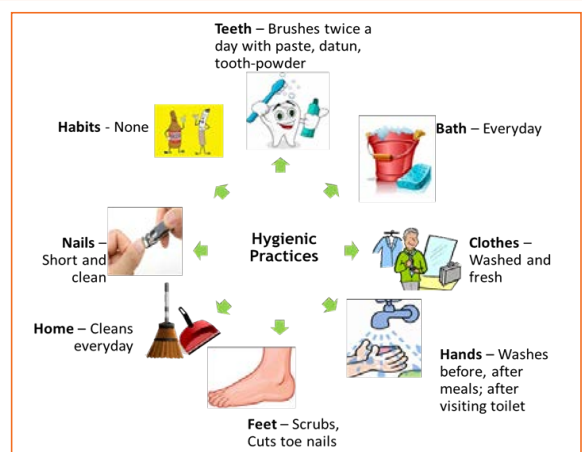

Fig.7.3.1: Personal Hygiene

Explain

- Why is maintaining personal hygiene considered important?
- If an employee doesn't maintain personal hygiene, can it have any effect on the people around him or the impression he makes on them?

Say

Physical fitness is very important for doing work effectively and efficiently. It can be maintained by different exercises like cycling, weight-lifting, jogging.

- It maintains optimal body weight.
- It reduces risk of diseases.
- It boosts confidence and self-esteem.
- It reduces stress, anxiety and depression

If employees are free from such danger of diseases due to various factors like sitting for long hours, etc. They can stay fit and this will eventually help in increasing productivity.

Healthy Eating

Eating food just for its taste wouldn't be of much good to our body. Excessively eating junk, over-consuming fried food, etc. can be detrimental to our health. Unhealthy eating habits can considerably affect the level of energy, concentration, etc.

For staying healthy, one should:

- Always try to eat home-made food
- Avoid oily food
- Always cook and eat fresh food
- Avoid junk food like burgers, carbonated drinks etc.
- Eat fruits regularly
- Drink lot of water

Alcoholism

It's the tendency during which one consumes alcohol to manage difficulties or to avoid feeling unhealthy.

Alcohol has the potential to interrupt almost every organ in the body as well as the brain. Uncontrolled consumption of alcohol not only affects a drinker's health but also human relationship and social standings.

- Reduced work focus and drop in performance
- Degradation in social and economic status
- Withdrawal symptoms like anxiety, trembling, fatigue, headache and depression etc.



Fig.7.3.2: Alcoholism

Activity

- Ask the students to make posters like- SAY NO TO SMOKING, etc. and ask them to wave them around the school.
- Also ask them to speak about the harmful effects of these bad habits on health.

Explain

- How can smoking effect the productivity of a worker?
- The intake of alcohol, cigarettes is increasing in India. What steps can be taken to handle minimize their use?

Say

The full form of AIDS is Acquired Immunodeficiency Syndrome. AIDS is caused by HIV (Human immunodeficiency Virus). It is the last stage of the HIV infection, if a person is HIV positive, he/she is suffering from AIDS.

According to a survey number of AIDS patients in India is between 2 to 3.1 million almost 50 % of total patients of AIDS. More men are HIV positive than women. A total of population of 0.29% females are suffering from AIDS while 0.43 % males are suffering

AIDS is transmitted by:

- Unprotected sexual relationships
- Contaminated blood transfusion
- Hypodermic Needles
- From infected mother to child

As per studies in India HIV/AIDS is largely due to unsafe sex worker interactions. About 86 % HIV incidents in the country is from unprotected sex. Migrant workers, truck drivers and majority of men who have sex with men pose greater risk of infecting their spouse and unborn children. People between 18-29 age groups accounts for 31 % of AIDS burden.

There are no medicines or vaccines for AIDS so far. The treatment and medicines which are available in the market are expensive and have side effects.

AIDS is not a disease like cancer or malaria, but is a condition that weakens a person's ability to fight diseases (immune system). AIDS not only affects you, but also has severe impact on family and friends. Even one mistake is enough to get HIV positive.

Activity

- To judge the understanding of the students, randomly pick up any of them and ask about topics like symptoms of AIDS.

Explain

- Discuss with the students if they have known anybody suffering from aids and noticed any social discrimination experienced by that person.
- Discuss the importance of spreading awareness about AIDS.

Notes for Facilitation

Suggestive Questions to ask students:

- Ask students to explain what is Positive Body Language..
- Ask students to define Personal Hygiene.

UNIT 7.4: Interpersonal Skill Development

Unit Objectives

At the end of the unit, students will be able to:

1. Develop a positive attitude and behaviour.
2. Understanding Goal Setting.
3. Motivated for team participation at work.
4. Manage relations.
5. Learn about Stress and anger management skills.
6. Develop leadership qualities.

Resources to be Used

- Available objects such as black or white Board, chalk pieces or white board marker pens, duster
- PC with LCD Projector or Flip Chart
- Participant Manual

Say

- Interpersonal skill development is the blend of different traits of day to day life that play an important role in creating our impression in other's mind. It starts from inside. The role of interpersonal skill development is to help us understand how to make choices about our attitudes and actions.
- One can learn to control over many aspects of our job and their environment by making appropriate choices and responses. These include various traits like:
 - » Positive Attitude
 - » Motivation
 - » Goal Setting
 - » Team Work
 - » Managing Relations
 - » Etiquette
 - » Stress and Anger Management
 - » Conflict Resolution

Activity

- Ask the students to organize themselves in groups of 10-12.
- Give them a time of around 30mins. And ask them to organize a 3mins. Play
- Ask them to solve all aspects related to the organization of of the play themselves.
- After the end of the time duration, ask the teams to perform one by one.
- Assess their performance.

Explain

- On the basis of the above activity, ask the students about the challenges faced by them in the process of preparation.
- Try to point out what could be the possible reason behind the hurdle faced.

Say

- The attitude of a person includes various aspects like- our approach, our outlook towards situations and others, the emotions we express towards others.
- A positive attitude has the ability to deal with even the most difficult situations.
- A positive attitude manifests in:
 - » Positive thinking
 - » Constructive things
 - » Creative thinking
 - » Optimism
 - » The motivation and energy to do things to accomplish goals
 - » An attitude of happiness
- Positivity not only affects a person to get the desired results in workplace but attracts people to his positive energy.

Activity

- Make 5-7 slips stating a difficult situation, for instance- there is an annual event in the school. Due to some reason the tent house people could not manage to come there and carry out the tent and other decoration work. The event is just 1hr away. How would you manage the situation?
- After everybody has received a chit, give the students a time of 2-4mins. to think over the situation and write a possible solution.

- Collect the slips of the people who have got same situations. Compare them in terms of practical application, positivity, etc.
- Suggest other possible solutions.
- Applaud the students whose answers show the correct attitude and will to deal with the situation using their creativity.

Explain

- An embroider who doesn't know how to carry out phulkari embroidery has been assigned the task of carrying it out due to labour shortage. Can he succeed in his work?

Explain

- Explain the following story to the students to explain them better about positive attitude.

Raju works as a Supervisor in a factory. He is not happy with his job. One day he spoke about his dejection to his elderly friend, Prashant, who runs a small canteen for the factory workers.

"Prashant I am not satisfied with my job. There are so many problems in the factory. If I solve one, another one crops up. The problems seem to be never ending. I am quite fed up and wish to quit."

Prashant said nothing. He quietly put three pots with water on the stove. He put some carrots into one pot, some eggs into another and coffee beans into the third pot. The water in the pots began to boil.

Raju wondered what was going on! "Oh, here I am with my tale of woes, and this illiterate cook goes about his business!"

After some time, Prashant switched off the stove and put the carrots, eggs and the beans in different bowls. He then said, "My friend, what do you see here?" "Carrots, eggs and coffee", said Raju irritably. "Of course! Now come and feel them one by one", said Prashant. "Oh God! What do you want to prove?" asked Raju controlling his anger. "The carrots have turned soft. The egg is hard boiled beneath its shell and the coffee is stronger in aroma". "Exactly" said Prashant "Each of them faced the same degree of heat, but each reacted differently. The carrots that were so hard before became soft and weak. The egg was fragile with its thin outer shell, but after boiling it became hardened and the inner liquid portion became hard boiled. But the coffee beans are unique. After boiling in water, they became stronger and richer. So my friend, tell me, are you the carrot, the egg or the coffee bean? How do you respond to difficult situations? Are you like the carrot that is hard to look at but with the slightest difficulty becomes weak and soft? Are you the egg born with a soft heart but became tough and stiff after a difficult or a bitter experience? Or are you like the coffee bean that gets stronger and tougher and reaches its peak in extreme adversity or difficulty?"

When things get worse, you get better.

"Thank you Prashant. You've opened my eyes. I shall strive and do my best."

Say

- Give examples of various successful people like Rajnikanth, Dhirubai Ambani who had a humble background but succeeded in achieving their goals.

Say

Goal setting is a powerful method for considering your ideal future. The method of setting goals helps you to decide on where you wish to go in life.

Goals should be SMART in nature.

- S : Specific
- M: Measurable
- A: Attainment
- R: Relevant
- T: Time bound

Setting goal is important for an individual because:

- Goals narrow attention and direct efforts to goal related activities.
- Goals lead to more effort.
- One works through setbacks if he is pursuing a goal.
- It develops and changes individual's behaviour.

Categorization of Goals

To give a broad balanced coverage of all important areas in your life set goals in all the important categories of your life such as:

- **Career:** What level do you want to reach in your career or where you want to reach?
- **Financial:** How much you want to earn, by what stage? How it is related to your career goals?
- **Education:** Is there any specific knowledge you want to acquire in life? What information and skills you need to acquire in order to achieve your goals?
- **Family:** How you want to be seen by your spouse and family members?
- **Health:** Do you want to stay healthy in your old age? What are you planning to achieve this?
- **Public Service:** If you want to make the world a better place, what will you do?.

We can see in the fig. that these goals are not independent. In some way or the other, they are dependent on each other. However, the degree of this dependence varies.

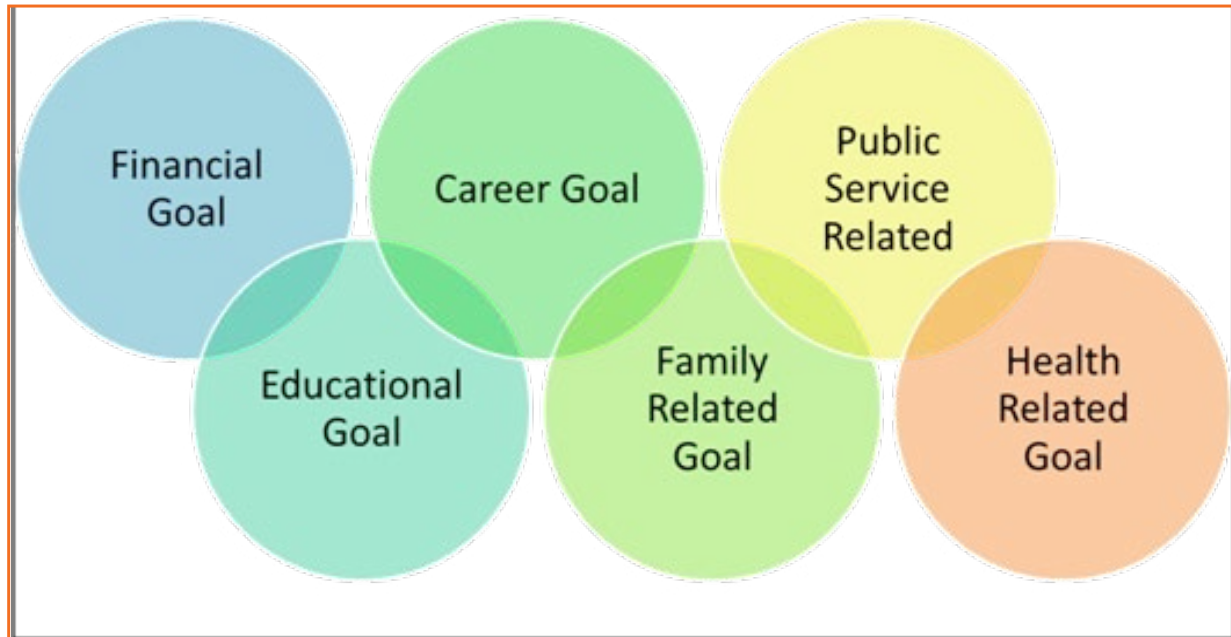

Fig.7.4.1: Goals

Activity

- Ask the students to write about different types of goals in their life.

Explain

- Discuss about the importance of setting goals in life.
- Discuss the importance of setting up short-term goals.

Say

- A team is made up of a group of people associated to a common purpose. Teams are especially made to conduct complex works. A team is an example where a people share a goal. This creates a dynamic bond amongst the team members as they are dependent on one another for success. For example a sports team wins or loses as a whole.

Team members need to learn:

- How to assist each other
- Realize their true potential
- Prepare the atmosphere that is familiar with each member to work beyond their strength.

Factors of Team Dynamics

- Tolerance and Cooperation
- Set aside feelings of caste, creed, profession
- Put up with each other
- Identify strengths of each
- Who can do what

Activity 

- Ask the students to divide themselves in groups of 7-8.
- Give each group the task of solving a series of riddles to reach the final destination that has different objects for different groups like needle for one, cloth for other and so on.
- While solving a riddle, the group members should not be standing with the other who is solving the riddle.
- In fact, the person who is solving it should give the clue obtained as an answer to the riddle and then the other should do the same. This would continue till the series of riddles is solved and the final object is reached.
- This gives a chance of teamwork, trustworthiness, etc. between the team members.

Explain 

- Discuss the importance of team dynamics in a badminton doubles match.

Say 

- Explain to the students the following story in order to make them understand the importance of coordination and teamwork without which an organization would not be able to work well.

Once there was a shoal of tiny red fish living in the sea. One among them was a little different. His name was Swimmy and he was black in colour. Swimmy was the fastest swimmer in the shoal. The fish would swim around in the sea looking for food. One day when they were busy searching for lunch, Swimmy who was far ahead of the others saw a big fish coming in their direction. The big fish was also looking for his lunch---smaller fish. Swimmy was scared! If the big fish would spot his shoal, all of them would be eaten up. Swimmy thought hard of a way out and quickly came up with a plan. He quickly swam back to his shoal and told all the fish about the big fish and also explained his plan to escape from being eaten.

When the big fish came closer he was shocked to see an even bigger fish swimming in his direction with its huge jaws wide open. Frightened that he would get eaten up, the big fish swam away. If he had looked carefully, he would have realised that the huge fish was actually all the tiny red fish swimming very closely together in such a way that they looked like one big fish. And little black Swimmy, being different, became the eye of the 'huge' fish!

Say

- We all have different personalities, different desires and wishes, and different ways of showing our emotions that affects people around us.
- 70% of the tailoring shop learning is informal, once people discuss with each other at work they really are learning to do their job better. Friendlier staff are effective communicators, more productive and trustworthy more by employers and colleagues.
- Tips for improving relations with people around us:
 - » Observe how you react to people such as do you reach to a conclusion before knowing all the facts.
 - » Look honestly how you think and interact with other people.
 - » Look at the work environment and behave accordingly.
 - » Accept your weaknesses courageously and work on them.
 - » Take responsibility for your actions.
 - » If you hurt someone's feeling apologize directly.

Activity

- Give the students a topic to discuss.
- Ask them to discuss about all possible aspects in the topic-negative and positive.
- Ask 2 students having opposing opinions to come forward and have a healthy debate.
- At the end of it, ask them what they have learnt from each other.

Explain

- Ask from the students whether they have ever felt awkward on a day when their friend was absent.
- Discuss the possible implications.

Say

Different people have different personalities. Their basic nature, the way they respond to others, etc. may not be same. In fact, this is what makes them different from others. However, in an official and public setting, a person doing simply what he wants may be uncomfortable for others around him/her. This brings into light, the importance of etiquettes.

Etiquettes are the customs or rules governing behaviour regarded as correct or acceptable in social and official life. Certain etiquettes that should be kept in mind are as follow:

- Stand straight, make eye contact and turn towards people when they are speaking and genuinely smile at people.
- Follow the dress code prescribed by the organization.
- Limit personal calls especially when you are working in a manufacturing unit.
- Eat and smoke to the designated areas only otherwise it may disturb other people.
- Apart from certain etiquettes, certain ethics are also expected to be followed by the employees of an organization. Ethics are basic rules regarding how people of a particular profession/professional setting are supposed to work. Certain work ethics include:
 - **Discipline:** It takes a certain level of commitment to finish your tasks every day. Only with discipline one can stay fixed on goals and determined to complete his assignment.
 - **Commitment to work:** A strong sense of commitment to work affects how an individual work and the amount of work he does. When a worker is committed to work he turns up on time, puts in his best efforts and completes the projects to the best of his ability.
 - **Punctuality:** It shows that you are dedicated to your work, interested in the work and capable of handling responsibility. Being punctual shows your professionalism and commitment to work.
 - **Ownership and responsibility:** Ownership and responsibility stretches in all aspects of an employee's job. Coworkers value the employees' ability to give honest feedback. Supervisors rely on the high moral standards trusting him not create problems and being responsible.
 - **Striving to excel:** Keep yourself updated with new developments and knowledge of your field. Learn new skills, techniques, methods required to uplift your career.

Activity

- Ask the students to narrate instances when they have been scolded by their school teachers/ elders for behaving inappropriately-like dragging one' feet while walking, etc.
- Look for other such instances.

Explain

- To test what the students have understood, discuss with them various etiquettes that need to be taken care of in a school.

Say

Anger is a normal and a healthy emotion. Anger management may be critical for people who find it difficult to keep it under control. There are many health issues related to an unresolved anger like heart attack, high blood pressure, anxiety, depression, colds and flu/fever and digestive problems. If your heart beats faster and you breathe quickly, tension in your shoulder or clenching your fists beware your body may be showing sign of anger, take steps to calm yourself down. Once you will be able to recognize the signs of anger you can calm yourself down.

- Anger can destroy lives, destroy relationships.

Do's

- Post pone for a few seconds whatever you wish to say or do.
- Take a deep breath.

Activity

- Ask the students about situations when they realized that their stress/anger disabled them from performing their best.

Explain

- Discuss the problem of increasing levels of stress and anger among the youth.
- Also discuss the ways to manage anger and stress.

Say

A problem or a situation that may be difficult to understand or to deal with.

- If a problem is not solved or addressed at the right time it may blow out of proportion
- An unsolved problem can be like Cancer which spreads and translates itself into all other areas in life
- Unsolved problems may lead to increased levels of bitterness and frustration
- It may foster bad habits like back-biting, gossiping, etc.
- Persons involved in conflict may lose focus and target each other's character instead of the specific behavior to be modified.

1. STOP . . .

before you loose your temper and make the conflict worse.

2. SAY . . .

what you feel is the issue. What is the reason of disagreement? What do you like?

3. LISTEN . . .

to others ideas and feelings.

4. THINK . . .

of solutions that satisfy both the parties.

If you still can't agree, ask someone else to help you work it out.

Activity

- Call out a student randomly.
- Ask them to narrate an incident when they had a fight with their friend and it resulted in further problems in school, became a cause for mental stress.

Explain

- Discuss the importance of resolving conflicts for a person's mental peace, maintaining order and healthy environment in workplace.

Say

The ability to lead effectively depends on variety of key skills. These skills are extremely sought after by employers as they involve managing a number of individuals in such a way on inspire, enthuse and build respect. Some of the qualities that every good leader should possess are:

- **Honesty:** If you make honest and ethical behaviour a key value your team will follow the suit.
- **Ability to delegate:** delegating task to one of the appropriate person is the one of the most important skills that needs to be developed. The key to delegation is to identify the core strengths of the team and capitalizing on them.
- **Good communications skills:** Being able to communicate clearly is quite important.
- **Confidence:** Keeps morale of the team high even in the tough times.
- **Commitment:** If you expect your team to work hard and produce quality content then you should lead by example.
- **Positive Attitude:** Keeping teams motivated towards continued success of the company.
- **Creativity:** During the critical situations it is important to think out of the box solutions than to prefer the set course of action.
- **Be decisive:** Plan for the unexpected and nothing will surprise you. If you have thought of things go wrong in a particular task you will be able to make confident decisions on corrective actions when necessary.
- **Focus on the big picture:** Plan future strategies for your department and communicate them to supervisors and staff members. Set realistic and measurable individual and team goals and communicate your expectations within the context of massive picture.

Activity

- Ask students to arrange themselves in group of 7-8.
- Assign each group the task of selling products of companies(enactment)
- Ask the group members to choose a leader.
- Ask the leader to coordinate different activities of his team members to create a collective campaign for the brand.
- Give them 20mins. Time for doing this.
- See the performance of different groups.
- Seeing the performance of each group, assess whether the leader has carried out his responsibilities well.
- Suggest changes, if necessary in the practices/ attitude of the leader.

Explain

- Discuss the role of a team leader in terms of team's performance.

Notes for Facilitation

Suggestive Question to ask students:

- Ask discussed topic relevant questions as per the unit from the students to check the learning outcomes.

UNIT 7.5: Social Interaction

Unit Objectives

At the end of the unit, students will be able to:

1. Describe the social interaction and its behaviours.
2. Give a brief description about himself/herself in public.
3. Follow daily duties.
4. Cooperate with peers, family and other members in society.

Resources to be Used

- Available objects such as black or white Board, chalk pieces or white board marker pens, duster
- PC with LCD Projector or Flip Chart
- Participant Manual

Say

Social interaction is a process through which we respond to people talking with us. It includes acts where people perform toward each other and responses they give in return. Social interaction has a number of behaviors. Some of them are:

- **Exchange:** Exchange is the most elementary kind of social interaction. It's a human process by that social behaviour is exchanged for some kind of reward for equal or greater value.
- **Competition:** It's a process by which two or more individuals plan to accomplish a goal that just one can attain. It will lead to psychological stress, a lack of cooperation in social relationship, difference and even conflict.
- **Cooperation:** It's a process in which people work together to achieve shared goals. Task cannot be completed without their cooperation.
- **Conflict:** Social conflict is the struggle for agency or power among a society to achieve control of scarce resources. It happens when two or more individuals oppose each other in social interaction to achieve incompatible goals.
- **Coercion:** People or teams are forced to provide in to the desire of other people or teams.

Activity

- Explain to the larger group that in a moment they will be dividing into smaller groups according to some commonality. For example “Divide yourselves into groups according to your favorite season!” At this time, all the people who enjoy summer get into a group, and so on.
- Once groups are formed, the facilitator points to each group and asks them to shout in unison what group they have formed. If another group has the same category, have the two groups merge and celebrate together.
- After all groups have been identified, the facilitator shouts out another type of division.
- This activity not only gives a chance to the students of knowing each other’s likes and dislikes but also facilitates traits like cooperation, coordination while having fun.

Explain

- Discuss the difference between a setting where people know each other well, are ready to cooperate and coordinate with a situation where people are not ready to resolve differences, etc.

Say

We all, in our lifetime, have to introduce ourselves to the others. The introduction usually lasts for around 2 minutes to 3 minutes. It is very important that it gives the first impression to other about us. It has a great impact on your self-esteem and self-confidence. It’s helpful in:

- Feeling better about yourself
- Boosting your confidence
- Building your self esteem
- Making friends
- Feeling in control.

Points that should be included in self-introduction are:

- » **Wishes:** It is the first thing that we need to do before addressing a gathering. At this point we need to make effort to grab the attention of audience. You have to wish depending on the time either, Good Morning, Good

Afternoon or Good Evening.

- » Good Morning! My dear friends.
- » Respected Sir! Good morning.
- » Special or lovely or cool morning to you all.

- **Purpose:** We have to tell the purpose of coming in front of the audience. We can say I have come here to tell you about myself.

Activity

- Randomly call out 3-4 students.
- Ask them to give an introduction of self.
- Suggest changes, if necessary in the way introduction has to be done/ information conveyed.

Explain

- Discuss the importance of a confident self-introduction.
- Also, discuss whether boasting about oneself while introducing is right.

Say

There are certain duties which are laid by the Constitution of India. These duties are very to be fulfilled by every citizen of India. These are as follows:

- To bear by the Constitution and respect its ideals and establishments, the national flag and also the national anthem.
- To encourage and respect the noble ideals that galvanized our national struggle for freedom.
- To uphold and protect the sovereignty, unity and integrity of Republic of India.
- To defend the country and render national service once called upon to do so.
- To promote harmony and also the spirit of respect amongst all the people of the Republic of India transcending religious, linguistic and regional diversities.
- To forbid practices derogative to the dignity of ladies.
- To preserve the rich and diversified heritage of our culture.
- To conserve the natural surroundings like forests, lakes, rivers and wild life, and to have compassion for living creatures.
- To develop the scientific temper, humanism and the spirit of inquiry and reform.
- To safeguard public property and to retract violence.
- To try towards excellence altogether spheres of individual and collective activity so that the nation perpetually rises to higher levels of endeavour and accomplishment.
- These need to be followed by every citizen of India for development of the country.

Activity

- Divide the students into groups of 7-8.
- Assign each group to come up with duties that are to be taken care of in different areas- say workplace, home, school, etc.

Explain

- Discuss what would be the situation if people do not follow their respective duties and responsibilities in different areas.

Say

- The process of groups of organisms working or acting together for their mutual benefit is called cooperation. Cooperation among family members, friends and peers is very common and healthy. It is the backbone of any society.
- Family cooperation provides an avenue for a family to come closer. It increases coping skills and decision making. Some steps to promote family cooperation are.

Activity

- Ask the students to choose a partner for themselves.
- Now, give each team a task of carrying out different types of stitches on different types of clothes.
- Ask them to divide the work between themselves and carry it out within a time span of 20mins (One can fetch the materials needed from other room from time to time, other could carry out the task of doing the actual stitch).
- Assess the performance of students.

Explain

- Based on the above activity, discuss the problems faced while doing the task.
- Also discuss what could have been the possible solutions to it.

Notes for Facilitation

Suggestive Question to ask students:

- Ask discussed topic relevant questions as per the unit from the students to check the learning outcomes.

UNIT 7.6: Group Interaction

Unit Objectives

At the end of the unit, students will be able to:

1. Participate in group discussions in the class.
2. Give speech in the public.
3. Describe the importance of team building and team work.

Resources to be Used

- Available objects such as black or white Board, chalk pieces or white board marker pens, duster
- PC with LCD Projector or Flip Chart
- Participant Manual

Say

- Every day we tend to meet with teams of individuals socially and professionally. However we interact to play a big role in the impressions we tend to produce. Interaction that happens whereas a group completes a cooperative task describes how the group works.
- For a successful and positive group interaction these steps needs to be followed:
 - » Put your mobile phone away or place in silent mode.
 - » Greet everyone.
 - » Be friendly with everyone in the group.
 - » Show an interest in others by paying someone a compliment and listen carefully to what is being discussed.
 - » Be proactive and introduce yourself to others in the group.
 - » Sit up straight. Poor body posture is an indication of low self-esteem.
 - » Focus your attention on the person talking.
 - » Consider everyone's comment. Remember everyone is different and have different the ability to think.
 - » Think before you speak. Don't be too quick to jump into the conversation.
 - » Be a respect listener and observer.
 - » Include everyone when talking. Be sure to share eye contact with each person in the group.
 - » Don't start or participate in a side conversation.
 - » Make sure to smile shake hands and embrace and use each person's name during discussion.



Fig.7.6.1: Group Interaction

Activity

- Give the class a topic to have a healthy discussion, say Effects of Modernization on Environment.
- Encourage them to come up with different points and all possible aspects.
- Ask people to support or negate a point according to their perspective.

Explain

- Observe students during the activity.
- If you find any of the persons flouting norms of a group interaction, guide him accordingly.
- Also discuss how does not complying with norms affect the ongoing/effect of a group interaction.

Say

As a participant group interactions is important as:

- It helps you to get a subject more deeply.
- It improves your strength to think positively.
- It helps in solving a serious issue.
- It helps the team to go on a final decision.
- It provides you the chance to listen to others' ideas.
- It improves your listening skills.
- It increases your confidence in communications.
- It can change your behaviour.

As a moderator a group interaction helps in:

- Understanding a member interpersonal skills.
- Identifying if a member is able to work in a team.
- Understanding ones behaviour.
- Selecting a perspective member in a perspective methodology.

Do's	Don't
<ul style="list-style-type: none"> • Speak pleasantly and politely to the group. • Respect the contribution of every speaker. • Remember that a discussion is not an argument. Learn to disagree politely. • Think about your contribution before you speak. How best can you answer the question/ contribute to the topic? • Try to stick to the discussion topic. Don't introduce irrelevant information. • Be aware of your body language when you are speaking. • Agree with and acknowledge what you find interesting. 	<ul style="list-style-type: none"> • Lose your temper. A discussion is not an argument. • Shout. Use a moderate tone and medium pitch. • Use too many gestures when you speak. Gestures like finger pointing and table thumping can appear aggressive. • Dominate the discussion. Confident speakers should allow quieter students a chance to contribute. • Draw too much on personal experience or anecdote. Although some tutors encourage students to reflect on their own experience, remember not to generalize too much. • Interrupt. Wait for a speaker to finish what they are saying before you speak.

Activity

- Try games like telephone, where you sit in a circle and one person whispers a scenario into the ear of the next person, such as how an important report was not delivered to the president in time.
- The “telephone” chain continues until the last person, who announces what he or she heard. Generally, by the end of the chain the story has been altered substantially.
- This gives employees a chance to discuss how the story changed along the way and methods they could use in the future to improve communication.

Explain

- Discuss the importance of interaction among your family members.

Say

- A good team is the one that motivates its members to have a positive attitude, perform better.
- Team work is a very important part of working life. They can have a big impact on the profitability of an organization, team and individual performance, company reputation, etc.
- Team building is important because:
 - » Facilitates better communication
 - » Motivates employees
 - » Promotes creativity
 - » Develops problem-solving skills
 - » Breaks the barrier
- Maintaining a team is not an easy job since there are a variety of people involved having different strengths and weaknesses. This task can be made easier by following certain do’s and don’ts
 - » **Don’t argue in public:** If you have a disagreement with someone in the team find a neutral place to discuss the situation.
 - » **Do encourage each other:** When things get tough the tough gets going. Contribute to the team in trying situation.
 - » **Don’t talk behind the backs:** If you have trouble with some team member don’t share with others. Go directly to the person in a kind and compassionate manner and share what is in your mind.
 - » **Do lend a hand:** If a team members is asking for help don’t hesitate in helping him.
 - » **Don’t be the weakest link:** Live up to your responsibilities, meet team expectations and communicate effectively in the team.
 - » **Give and receive feedback:** As a part of growing team give and receive feedback respectfully and graciously .

Activity

- Ask students to organize themselves in a team of 7-8.
- Assign them the task of giving a presentation on different types of stitches.

Explain

- On the basis of the activity, ask the students to judge who was the best team member.
- Discuss the qualities of this person so that other people can improve themselves and cooperate and be more effective in future.

Notes for Facilitation

Suggestive Question to ask students:

- Ask students to explain the importance of Group Interaction
- Ask students to explain what is meant by Team work.

UNIT 7.7: Time Management

Unit Objectives

At the end of the unit, students will be able to:

1. Describe the importance of time management.
2. Develop time management skills.
3. Learn about effective time planning.

Resources to be Used

- Available objects such as black or white Board, chalk pieces or white board marker pens, duster
- PC with LCD Projector or Flip Chart
- Participant Manual

Say

Time management is the process of planning and practicing control over the time given to a specific task, especially to increase effectiveness, efficiency and productivity. It is an activity with the goal to increase the overall advantage of a set of activities within the limited condition of a limited time.

Some effective time management

- Delegate tasks.
- Identify time wasters.
- Combine activities – Plan for them.
- Break down big tasks down to the smallest task possible.
- Accomplish them one by one.
- At the end of the day conduct a simple analysis to see which activity took time.



Fig.7.7.1: Time Management

Activity

- Ask the students to assemble in groups of 9-10 in ground.
- Organize a race that is broken into various stages like lemon race, followed by one-leg race and balloon race.
- Ask the team members to decide among themselves who will do what.
- The team that would be able to complete the task within a time of 4mins/ at the earliest would be the winner.

Explain

- On the basis of the activity, discuss the factors that caused the team members lag behind and which factors enabled them to carry it within the assigned time.
- Relate it to the wider arena- that is to time management (when more than 1 person is involved) in general sense.

Say

- Time robbers are those activities which create interruption at the tailoring shop. These activities create a deviation from the objectives which needs to be achieved. Time Robbers could be:
 - » Poor personal planning and scheduling.
 - » Interruptions by people without appointments.
 - » Poor delegation.
 - » Poor use of the media: Telephone, Mobile, e-mail, and fax, etc.
 - » Reading junk mail.
 - » Lack of concern for good time management.
 - » Lack of clear priorities
- However, time robbers are not inevitable. They can be kept in check. The Time Robbers can be avoided by:
 - » Being active all the time
 - » Developing and maintaining an organized personal activity schedule
 - » Setting priorities
 - » Proper delegation
 - » Utilizing modern technical media

Activity

- Divide students into groups of 3-4.
- Ask them to choose a fabric of their choice, cut it in a particular shape and perform any embroidery of their choice.
- Give them a time limit of around 30mins.

Explain

- On the basis of the activity, discuss what factors caused delay in time (if any).
- Also discuss what can be done in future to avoid such wastage of time.

Say

- According to this 80% of the tasks can be completed in 20% of the time. The remaining 20 % of the tasks take 80 % of your time. And the task which should fall in first category should be given a higher priority.
- Time also depends on the type of method adopted to process the task. Methods should always be simpler and easier to complete the task. If we use difficult ways, it shall be result the waste of time. One should always try to find out alternate ways to complete a task.

Urgent Important Matrix

1.The Urgent and Important Tasks	2. The Non Urgent but Important Tasks
DO NOW <ul style="list-style-type: none"> • Emergencies, complaints and crisis issues • Demands from superiors • Planned tasks or project work now due • Meetings with superiors/colleagues 	PLAN TO DO THEM <ul style="list-style-type: none"> • Planning, preparation • Scheduling • Designing, testing • Thinking, creating, modeling the data
3. The Non Important but Urgent Tasks	4. The Non Important and non-Urgent Tasks
REJECT AND EXPLAIN <ul style="list-style-type: none"> • Trivial requests from others • Apparent emergencies • Misunderstandings appearing in work • Pointless routines or activities 	RESIST AND CEASE <ul style="list-style-type: none"> • Comfort' activities, computer • Games, net surfing, excessive • Cigarette breaks • Chat, gossip, social • Communications • Reading irrelevant and useless material

This matrix helps you understand:

- What should be done
- What should be planned
- What should be resisted
- What should be rejected

Activity

- Ask each student to name the activities he engages in after going back to home.
- Ask him to categorize them as 'most important', 'important' or 'least important'.
- Discuss the list.
- Compare answers of different students.

Explain

- Discuss the importance of categorization of tasks in terms of time management.

Notes for Facilitation

Suggestive Question to ask students:

- Ask discussed topic relevant questions as per the unit from the students to check the learning outcomes.

UNIT 7.8: Resume Preparation

Unit Objectives

At the end of the unit, students will be able to:

1. Describe the different sections of a resume.
2. Learn how to prepare a resume.

Resources to be Used

- Available objects such as black or white Board, chalk pieces or white board marker pens, duster
- PC with LCD Projector or Flip Chart
- Participant Manual

Say

- A resume is a self-declaration which once done properly shows how an individual's skills, experience and achievements matches the need of the work that they wish to get. The sole purpose of a resume is one to win an interview. It convinces the future employer what he wants from the prospective employee in new career or position.
- It also establishes an individual as a professional person with high standards and excellent writing skills based on the fact that his resume is written well. It also helps you clarify your direction, qualifications and strengths, boost your confidence or to start out the process of committing to a job or a career modification.

Say

It includes basic details that are used to identify/contact a person in case he has to be called for the interview.

- Do not include your photo.
- Do not write your resume as a heading to the file
- Do not occupy much space to fill insignificant information like marital status, etc.

Say

Purpose: To convey the employer what goals you have. The focus should be towards getting a particular position in a specific industry.

Always remember:

Your objective should include the following:

- Position wanted
- Functional area
- Industry wanted
- Be specific and restrict it to minimum words.
- You objective should be different to each role you apply to
- While writing the objective, keep the employers requirement in mind. The objective is not what you desire from the company, it's about company's need.

Say

The next session in your resume is to highlight your educational qualifications.

Purpose: For the employer to know whether you have basic qualification for the job for which you are applying or not.

- For class 10 and 12 – include school/college name, Board, Stream/Specialization (If any), year study, Marks.
- For undergraduate – include college name, University name, Degree and Specialization, year of study.
- Write all your qualifications in reverse chronological order, i.e. the latest qualification on top.
- You may write the educational qualifications in a tabular format or in a simple one after the other order.

Say

The next part of your resume includes the hands on work that you have done, like projects, internships, in-plant training, part time jobs, volunteering, starting up a company and other initiatives. The number and the nature of initiatives taken defines whether to keep one heading or detail them under different headings.

- This is a critical component of resume, as it reflects the initiatives one has taken apart from curriculum.
- It not only reflects one's real potential but helps in differentiating one's resume from peers.
- The heading should be – title / project name, role, company/organisation name, -2 lines description about the specific time period.
- Time period is must.
- The entries under each heading must be in reverse chronological order
- Be very specific on what you have accomplished. Add numbers and facts wherever possible.

Say

- List your skill and add a point which supports your skill the best.
- Make specific points. Add numbers and facts wherever possible.
- Pick only three to four soft skills that describes you the best.
- Dig your past to discover the best of these skills you possess and the best instance you can quote to support it.

One can have multiple headings under skills. Common heading can include:

- **Soft Skills:** Must include, they showcase your personality traits.
- **Core occupational skills:** Optional include if you possess any core skills. These are skills you possess relevant to the role you are applying for.
- **IT Skills:** Optional, Advisable to include this if you are applying for IT/software related roles.

Say

In this section of your resume carefully choose which of interests you want to showcase on your resume so that they can make your life seem meaningful.

The interests you showcase talk about your character. These interests frequently come up as a subject of discussions during the interviews, therefore sagely choose what to show.

- List interests which are meaningful and display some learning.
- Support the interest you have listed
- Make points specific and add supporting fact to it.
- Do not just list random cluster of interests like: adventure, guitar, reading, environment
- Never include interests like partying, watching movies etc. they create wrong impression.

Say

Give References

- The very last thing on your resume ought to be a list of 2-4 professional references. These are all those who you're not related to, but whom you have handled in a professional manner. you would possibly think about previous leader, faculty member or volunteer coordinator to include on your reference page.
- Include the name of the reference, their relationship to you, mailing address, e mail and telephone number.
- The place you're applying to could contact these people, therefore always call them in advance to allow them to understand that you are using them for a reference and are presently applying for a job.

Say

Make sure that the length of your resume does not exceed 2 pages.

- Do a thorough recheck and make sure there are absolutely no errors in your resume. No grammatical errors, no spelling mistakes, no punctuation errors.
- Run through your resume time and again for to make improvements and wording sentences better.
- Choose a professional font in a size 11 or 12. You can use multiple fonts for different parts of resume, but try to limit it maximum of two fonts. Instead of changing between fonts, try making specific sections bold or italicized instead.
- The font size of your header and the introduction to a section may be a size 14 or 16.
- Your text should always be printed in solid black ink. Make sure to deactivate any hyperlinks so that they don't print in blue or other contrasting colour.
- Your page should have one inch margin all the way around with 1.5 or 2 point line spacing. The body of your resume should align left and your header should be centered at the top of the page.

Activity

- Ask the students to prepare their resume.
- Guide them, if necessary.

Explain

- Discuss with the students the type of language and font that should be used in a resume.
- Also, discuss why a long resume should be avoided.

Summarize

- Give the students a summary of do's and don't's while making a resume.

Notes for Facilitation

Suggestive Question to ask students:

- Ask discussed topic relevant questions as per the unit from the students to check the learning outcomes.

UNIT 7.9: Interview Preparation

Unit Objectives

At the end of the unit, students will be able to:

1. Describe the procedure of interview.
2. Go thorough mock interviews.
3. Present self during an interview.
4. Motivated to work after the training period is over.

Resources to be Used

- Available objects such as black or white Board, chalk pieces or white board marker pens, duster
- PC with LCD Projector or Flip Chart
- Participant Manual

Say

- An interview is a conversation between two or more people (the interviewer(s) and the interviewee) where questions are asked by the interviewer to obtain information from the interviewee.

Common Types of Interview

- **Traditional HR Interview:** Most interviews are face to face. The most traditional is a one-on-one conversation with the HR Executive. Maintaining a good eye contact, listening keenly and giving prompt answers is advised.
- **Panel Interview:** In this situation, there is more than one interviewer. A panel ranging from two to ten members may conduct this part of the selection process. This might be scary for most people. However, it helps in showcasing how a person can deal with pressure confidently and patiently without losing his calmness.
- **Technical interview:** The objective of this interview is to basically evaluate technical knowledge. Majority of the questions will be based on the skills sets mentioned in the candidate's resume.
- **Telephone Interview:** Telephone interviews may also be used as a preliminary interview for candidates who live far away from the job site.
- Confident
- Relaxed
- Sure of yourself
- Prepared
- Before, during and after the interview, it is important for you to be prepared.
- Dress Professionally

- Choose your words properly
- Maintain an eye contact

To have a good impression and convey one’s level of seriousness, formal attire, minimalistic jewellery and clean and simple shoes are advised.

Say

- Some of you might have faced an interview and some of you might not have. However, by now, you definitely have a better understanding what are the accepted standards of a professional behaviour.

Activity

- Ask the students to answer. Discuss why each of the activity falls in a ‘do’ or ‘don’t’ category.

Sentence	Do’s	Don’ts
Be yourself		
Burp while talking!!!		
Just out from a ‘powder factory’ (worn too much make-up)		
Reach just about the right time for the interview		
Just barge in the cabin/ office		
Forget to greet the receptionist/ don’t respond		
Think before you speak		
Do your homework- Visit the company website		
Take time to think (TTTT)		
Wear bright colour clothes on the D-day		
Emphasis on your strengths		
Argue/ Debate with the interviewer		
Chew gum during the interview.		
Review your educational and work experiences		
See your documents flying out of the file (Being clumsy)		
Thank the interviewer		
Have the ‘they need me’ attitude		
Maintain eye contact and good body language		
Only give monosyllabic answers(depends on the kind of questions asked... in-between)		
Carry a copy of your resume		

Explain 

- Discuss with the students whether telling lies about oneself during the interview is right or wrong.

Say 

- Apart from the content of one's answers (choice of one's words, etc.) ,the tone at which one presents himself is of considerable importance.
- Also, one should be fully aware about what he has written in the resume and have proper reasons for writing it and should not write anything shallow.
- While, undergoing an interview, following things should be kept in mind:
 - » Be confident, not arrogant
 - » Sell yourself - Keep your energy up
 - » Maintain your posture
 - » Be positive, don't complain

Activity 

- While conducting mock interviews in pairs, notice the body language, tone, etc. of students minutely.
- Give suggestions, if necessary.

Explain 

- Discuss the importance of maintaining an eye contact with the interviewer.

Say 

- Clarity on ideas and expressions
- Correct language
- Good body language
- Fluency
- Ideas should be expressed fluently in the right tone, right voice, and right articulation.

Activity

- Read out a passage to students.
- While reading, intentionally mispronounce certain words.
- Ask the students to stop you as soon as you mispronounce a word.
- Ask the students to carry it among themselves whenever they get free time.
- This would aid a great deal in knowing and developing their active listening skills.

Explain

- Discuss the importance of active listening on the part of students when a teacher is explaining a topic.

Activity

- Also, ask them to conduct mock interviews in groups of 2.

Notes for Facilitation

Suggestive Question to ask students:

- Ask discussed topic relevant questions as per the unit from the students to check the learning outcomes.



Skill India
शिक्षणं मरणं - कृषणं मरणं



GOVERNMENT OF INDIA
MINISTRY OF SKILL DEVELOPMENT
& ENTREPRENEURSHIP



NSDC
National
Skill Development
Corporation

Transforming the skill landscape



8. Maintain Health, Safety and Security in Tailoring Shop

Unit 8.1 - Maintain Health, Safety and Security in Tailoring Shop

Unit 8.2 - First Aid and CPR

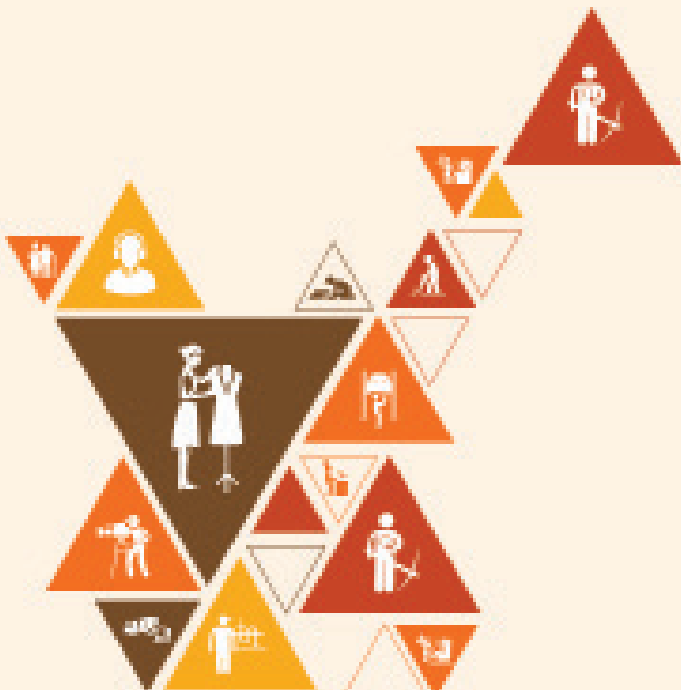

AMH/N1950

Key Learning Outcomes

At the end of this module, you will be able to:

1. Comply with health and safety related instructions applicable to the tailoring shop.
2. Follow environment management system related procedures.
3. Store materials and equipment in line with manufacturer's and organizational requirements.
4. Safely handle and move waste and debris.
5. Minimize health and safety risks to self and others due to own actions.
6. Monitor the tailoring shop and work processes for potential risks and threats.
7. Participate in mock drills/ evacuation procedures organized at the tailoring shop.
8. Undertake first aid, fire-fighting and emergency response training, if asked to do so.
9. Take action based on instructions in the event of fire.

UNIT: 8.1 Maintain Health, Safety and Security in Tailoring Shop

Unit Objectives

At the end of this unit, the students should be able to:

1. Comply with health and safety related instructions applicable to the tailoring shop.
2. Follow environment management system related procedures.
3. Store materials and equipment in line with manufacturer's and organizational requirements.
4. Safely handle and move waste and debris.
5. Minimize health and safety risks to self and others due to own actions.
6. Monitor the tailoring shop and work processes for potential risks and threats.
7. Participate in mock drills/ evacuation procedures organized at the tailoring shop.
8. Undertake first aid, fire-fighting and emergency response training, if asked to do so.
9. Take action based on instructions in the event of fire.

Resources to be Used

- Available objects such as black or white Board, chalk pieces or white board marker pens, duster
- PC with LCD Projector or Flip Chart
- Copies of handouts, Participants Handbook

Do

- Greet and welcome the participants to the next session of the program.
- Before starting the session ask them do they have any doubts pertaining to the previous unit.
- Capture their responses on board and share them wherever necessary.
- Tell them that they will learn about Finishing Department Workflow

Say

- Introduce the students to the health hazards that they might face in this employment over the long run.
- Explain the potential injuries and illnesses that apparel workers might face.
- Tell them about the environmental standards that should be taken care by them.
- Make them understand the value of daylight and positive health aspects.
- Explain the importance of essential facilities and their presence.
- Explain the importance of proper sanitation facilities.

Elaborate

Ergonomically-designed job ensures that an employee who is tall is given a comfortably enough space in or near his/her workspace so that the work efficiency is not hindered. Similarly, an employee who is shorter is able to reach all of his or her tools and products without upsetting comfort and safe assortment. Workers are usually compelled to work in the confinement of the job or workstation that previously was designed with no dynamism or change when they are hired. This leads the workforce to work in difficult postures and positions, all of which may result in work-related injuries/disorders.

Injuries and illnesses among textile and apparel workers

- 81% complained CTDs to the wrist.
- 70% of Tailor complains of back pain.
- 49% of workers is suffering from neck pains.
- 35% report obstinate lower back pain.
- 25% have suffered a compensable increasing trauma disorder
- 14% reported CTDs to the elbow.
- 5% reported CTDs to the shoulder.
- Absenteeism increases as working conditions worsens.
- High employee turnover is associated with detrimental working conditions.
- Embroidery tasks are associated with pain in the shoulders, wrists, and hands.
- Ironing by hand is associated with elbow pain.
- Fitting fabric in frames like of work, are associated with CTDs of the hands and wrists.

Some fundamental ergonomic principals that should be followed in our tailoring shops are:

- **Proper tools:** Tools and equipment provided at work place should be appropriate for the specific tasks being performed. The apparatus should allow the workers to keep their hands and wrists straight – the position they would be in if they were droopy relaxed at your side. The workers should bend the tool– not the wrist. The tool should fit easily into the hand. If the grip size is too large or too small, it will be uncomfortable and will increase the risk of injury. Tools should not have sharp edges.
- **Keep repetitive motions to a minimum:** Workstations or tasks can often be redesigned to reduce the number of repetitive motions that must be performed. Using a power-driven screwdriver or tools with a ratchet device can reduce the number of twisting motions with the arm. For prevention of ergonomic injuries, workers should be encouraged to change work and take frequent but short breaks. Work stations should have enough space for the given tasks and provide proper seating. Manufacturing tools and machinery should incorporate ergonomic design principles and should not require an excessive amount of force to operate. Some tasks can be automated or redesigned to eliminate repetitive movements and musculoskeletal injuries.
- **Avoid awkward postures:** Your job should not require you to work with your hands above shoulder height on a regular basis. Arms should be kept low and close to your body. Bending and twisting of your wrists, back and neck should also be avoided.
- **Use safe lifting procedures:** Avoid lifting objects that are too heavy. Use more than one person or a mechanical device to reduce the load. Your workstation should not require you to lift objects above your head or twist your back while lifting. Keep the load close to your body and ensure that you have a good grip. Heavy and frequently lifted objects should be stored between knee and shoulder height – not on the ground or above your head.

- **Get proper rest:** The workers need to rest their body and mind in order to prevent injuries. Give your muscles a rest during your coffee breaks, lunches and weekends by doing something different from what you do in your job.

For example, if you stand all day, while performing your job you should sit down to rest your legs and feet during your breaks. If you sit down, when working you should stand up and walk around during your breaks to give your back a rest and to increase circulation in your legs. By doing this the musculoskeletal injuries can be prevented.

- **Other things to consider:** Chemicals also have a part in garment manufacturing. Dyes, enzymes, solvents and other chemicals are used to create different fabric finishes and provide durability to the product. Proper ventilation and personal protective equipment are important for protection of workers engaged in chemical processing. Similarly, for workers who handle the finished material and may be exposed to excess chemicals and off-gassing, protective equipment should be used.

Good Lighting for Quality Products

Good lighting does not mean more light bulbs and more use of electricity. Natural lighting is usually a better option than the bulbs. But if there is a difficulty in arranging for a natural lighting through windows and ventilators, it's important that the bulbs and other elements of artificial lights should be well-maintained. A good lighting arrangement is directly proportionate to an efficient workforce.

You will learn from this topic how to attain better lighting without increasing the electricity bill; you may even pay less and your business, as well as the workers, will definitely benefit from these improvements. First of all, one has to identify if at all you need to work upon the existing brightness level in the work place

Lighting requirements are reliant on three main features

- The nature of the task
- The sharpness of the worker's eyesight
- The environment of the working area
- natural light is the best and the cheapest source of illumination. One had to gauge the surface area of the work area and measure the windows and skylights. Ideally the open space that includes the windows, ventilation windows and door should be one-third of the total area of work.

Natural light is the best and the cheapest source of illumination. One had to gauge the surface area of the work area and measure the windows and skylights. Ideally the open space that includes the windows, ventilation windows and door should be one-third of the total area of work.

Reporting an Accident and an Incident

Your responsibility requires you to be aware of potential hazards and correct reporting processes. If you notice a potentially hazardous situation, eg: a client expressing violent behavior, it is important that you report it immediately to management and fill out the appropriate forms as legally required of you.

If they are injured at work they must:

- Report the injury to management as soon as possible, and certainly within 24 hours.
- Seek proper treatment for their injury.

Sanitary Facilities

There are several reasons why the provision of washing facilities is important:

- Dirt and grime can be ingested and cause sickness or disease; they are, in any case, unpleasant and demoralizing.

- Washing is a necessity when women have their monthly periods.
- Washing is required for basic hygiene after using the toilet

Ready for Emergencies

Accidents can happen even if proper preventive measures are installed; so, always be prepared for emergencies, like cuts and bruises, eye injuries, burns, poisoning and electric shocks. Every enterprise, therefore, has to maintain a well-stocked first-aid box and assign at least one person from every shift to handle emergencies.

First-aid boxes should be clearly marked and located so that they are readily accessible in an emergency. They should not be more than 100 metres away from any place on the work site. Ideally, such kits should be near a wash-basin and in good lighting conditions. Their supplies need to be regularly checked and replenished. The contents of a first-aid box are often regulated by law, with variations according to the size and the likely industrial hazards of the enterprise. A typical basic kit may include the following items in a dustproof and waterproof box:

- Sterile bandages, pressure bandages, dressings (gauze pads) and slings. These should be individually wrapped and placed in a dustproof box or bag. Sufficient quantities of the different sizes should be available at all times to treat small cuts and burns.
- Cotton wool for cleaning wounds
- Scissors, tweezers (for splinters) and safety pins
- An eye bath and eye wash bottle
- Ready-to-use antiseptic solution and cream
- Simple over-the-counter medicines such as aspirin and antacid
- A booklet or leaflet giving advice on first-aid treatment

First aid requires some training, but this is not difficult to arrange in most places. The names and location (including telephone number) of those responsible for first aid should be put on a notice board. Worker involvement, especially for emergency situations, is strongly advised and everyone should know the procedures for obtaining medical assistance. Small establishments without their own facilities should keep contact with a nearby clinic or hospital, so that the time between the occurrence of an accident and medical assistance is very short, preferably much less than 30 minutes. Transport to the clinic or hospital should also be pre-arranged. An outside ambulance may be called in, if necessary. It is also desirable to have a stretcher available.

Safety Signs at Workplace

Safety Signs: A sign informs and instructs about safety and health at work by means of a signboard, a colour, an illuminated sign or acoustic signal, a voice or hand signal.

Activity

In the industry visit, make sure that the students:

- Use and maintain personal protective equipment as per protocol.
- Maintain a healthy lifestyle and guard against dependency on intoxicants.
- Follow environment management system related procedures. » Identify and correct (if possible) malfunctions in machinery and equipment.
- Store materials and equipment in line with manufacturer's and organizational requirements.

- Minimize health and safety risks to self and others due to own actions.
- Monitor the workplace and work processes for potential risks and threats.
- Carryout periodic walk-through to keep work area free from hazards and obstructions, if assigned.
- Report hazards and potential risks/threats to supervisors or other authorized personnel.
- Participate in mock drills/ evacuation procedures organized at the workplace.
- Undertake first aid, fire-fighting and emergency response training, if asked to do so.
- Take action based on instructions in the event of fire.

Notes for Facilitation

- Summarize the main points.
- Ask participants if they have any doubts.
- Encourage them to ask questions.
- Answer their queries satisfactorily.
- Tell participants to complete the questions at the end of the unit.
- Ensure that every participant answer all the questions.

Suggestive questions to ask students

- Ask students to list some fundamentals ergonomic principles that should be followed in SMO's workplace.
- Ask students to explain safety signs of workplace.

Unit 8.2: First Aid and CPR

Unit Objectives

At the end of the unit, students will be able to:

1. Identify different methods of first aid.
2. Perform first aid.
3. Understand CPR.
4. Perform CPR in case of emergency.

Notes for Facilitation

- You could ask the students about the expectations from the course.
- Invite students to participate. List the expectations on the whiteboard.
- Give the students a brief overview of what all will be covered in the program.

Say

First aid is the help given to any individual suffering from an unforeseen illness or injury, with care provided to preserve life, stop the condition from worsening, and/or promote recovery. It includes initial intervention during a serious condition before skilled medical help being accessible, like performing CPR while waiting for the ambulance, also because the complete treatment of minor conditions, such as applying a plaster to a cut. First aid is usually performed by the layman, with many of us trained in providing basic levels of first aid, and others willing to try and do thus from acquired information.

Do

- Explain the importance of being aware of CPR and other First Aid methods

Demonstrate

- Show them the CPR process on a dummy
- Show them the contents of a First Aid Box

Activity

- Conduct a skill practice activity.
- Ask the students to assemble together.
- Explain the purpose and duration of the activity

Skill Practice	Time	Resources
1. Practice CPR on a dummy	1 hour	Dummy



Skill India
कौशल भारत - कुशल भारत



सत्यमेव जयते
GOVERNMENT OF INDIA
MINISTRY OF SKILL DEVELOPMENT
& ENTREPRENEURSHIP



N · S · D · C
National
Skill Development
Corporation

Transforming the skill landscape



9. Employability & Entrepreneurship Skills

Unit 9.1 – Personal Strengths & Value Systems

Unit 9.2 – Digital Literacy: A Recap

Unit 9.3 – Money Matters

Unit 9.4 – Preparing for Employment & Self Employment

Unit 9.5 – Understanding Entrepreneurship

Unit 9.6 – Preparing to be an Entrepreneur

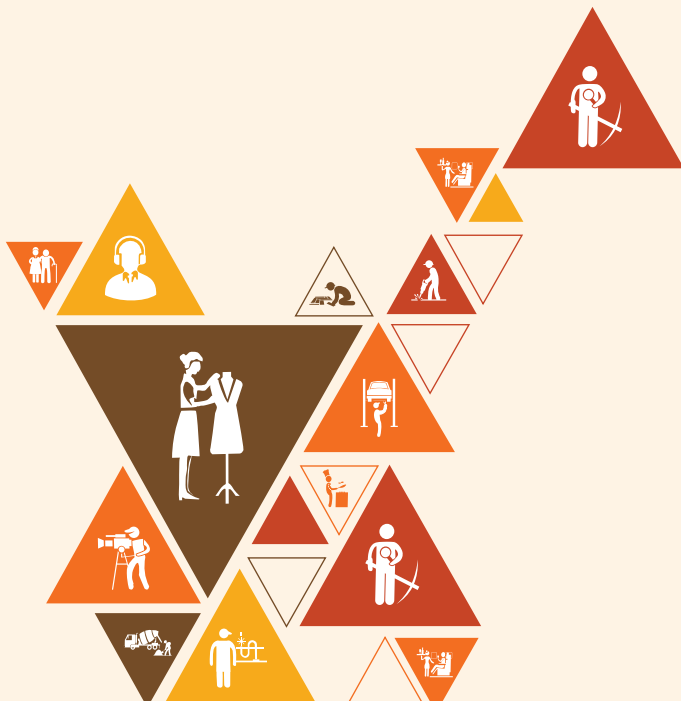

Introduction: Employability and Entrepreneurship Skills

This Facilitator's guide includes various activities which will help you as a facilitator to make the sessions participative and interactive.

Ice breaker

- You can begin the module with the following ice breaker:

Five of Anything Ice Breaker Steps:

- Divide the participants into groups of four or five by having them number off. (You do this because people generally begin a meeting by sitting with the people they already know best.)
- Tell the newly formed groups that their assignment is to share their five favourite movies of all time, their five favourite novels or their five least liked films. The topic can be five of anything - most liked or disliked.
- This ice breaker helps the group explore shared interests more broadly and sparks lots of discussion about why each person likes or dislikes their selected five.
- Tell the groups that one person must take notes and be ready to share the highlights of their group discussion with the class upon completion of the assignment.

Expectation Mapping

1. During the first session and after ice breaker session, ask the participants to answer the following question: "What do I expect to learn from this training?"
2. Have one of the participants write their contributions on a flip chart sheet.
3. Write down your own list of covered material in the training on another flip chart sheet.
4. Compare the two sheets, commenting on what will and what will not be covered during the training.
5. Set some ground rules for the training sessions. Ask the participants to put these rules on a flipchart and display it in the class.
6. You may get back to those sheets once again at the end of the last session of the training.
7. Benefits of doing this activity:
 - Participants feel better as their opinions are heard.
 - Participants get to know what they should expect from the training.
 - The facilitator gets to know which points to emphasize, which to leave out, and which to add during the training.
8. Expectations from the participants:
 - Must sign the attendance sheet when they arrive for class.
 - Conduct themselves in a positive manner
 - Be punctual, attentive, and participative
9. Explain the contents that are going to get covered one by one and connect it with the expectation mapping done earlier.
10. By the end of this exercise, the participants should have a clear understanding of what to expect from the session and what are the areas that will not get covered.

Defining Objectives

1. Defining the objectives in the beginning of the units sets the mood for the unit.
2. To begin with the end in mind sets the expectations of the participants as what could be the important takeaways from the session.
3. It is also a way of making participants take responsibility of their own learning process.
4. For the facilitator, the objectives decide a designed path to progress on so that the learning stays aligned and on track.

5. Read the objectives slowly, one by one, and ask the participants to explain what they think it means.
6. At the end of the session, you could again revisit the objectives to find out from the participants about how many objectives have been achieved.

In order to effectively facilitate this workshop:

1. You must have thorough knowledge of the material in the Participant Handbook, and be prepared to answer questions about it.
2. You may also wish to read other material to enhance your knowledge of the subject.
3. There may be issues raised with which you are not able to deal, either because of lack of time or knowledge. You can either state that you will obtain answers and get back to the participants with the information. In case the query can be turned to an assignment to the class, do so. You can work with the the participants on the assignment.
4. You must have a very clear understanding of what the participants want to accomplish by the end of the workshop and the means to guide the participants.
5. As the facilitator, it is your responsibility to make sure that all logistical arrangements are made for the workshop. This may involve doing it yourself or confirming that someone else has made all necessary arrangements associated with the workshop. Assume nothing and check everything before the workshop begins.
6. To break the monotony and boredom during sessions, introduce mini breaks in the form of stretching exercises, jokes, some group songs or games.
7. Invite discussion from the participants.
8. Probe the participants further and lead them to come to affirmative conclusions.
9. Let the participants answer. No answer is incorrect.
10. Ask one participant to write all the points on the whiteboard.
11. Build the sessions from the answers provided by the class.
12. Prepare for the sessions in advance so that the resources like flipcharts, handouts, blank sheets of paper, marker pens, etc. can be kept ready.
13. Ensure that resources like board, markers, duster etc. is available before your session starts.

General instructions for role playing:

1. You are not being asked to be an actor or to entertain. The purpose of the role play is to provide a situation in which you can practice certain skills.
2. When you read the brief, try to imagine yourself in the situation described and behave in a way you feel to be natural – but be conscious of the fact that your role may require a different approach from that which you might normally use.
3. You (and others) may benefit from the change in approach and behaviour. Therefore, try to use the approach you feel to be most appropriate for the circumstances described in your brief.
4. The brief is just the starting point. It simply sets the scene and the tone of session or activity. Try not to keep referring to the brief as this will affect the spontaneity of the meeting. Allow the role play to develop as you think it might in real life and change your reactions in line with the behaviour and responses of others involved.
5. If you find that you have too little information to answer questions or to describe what has happened in the situation, do feel free to add your own thoughts and ideas. Try to keep these within the framework of the role you are taking and try to make your improvisations as realistic as possible.

UNIT 9.1: Personal Strengths & Value Systems

Key Learning Outcomes



At the end of this unit, participants will be able to:

1. Explain the meaning of health
2. List common health issues
3. Discuss tips to prevent common health issues
4. Explain the meaning of hygiene
5. Discuss the purpose of Swacch Bharat Abhiyan
6. Explain the meaning of habit
7. Discuss ways to set up a safe work environment
8. Discuss critical safety habits to be followed by employees
9. Explain the importance of self-analysis
10. Discuss motivation with the help of Maslow's Hierarchy of Needs
11. Discuss the meaning of achievement motivation
12. List the characteristics of entrepreneurs with achievement motivation
13. List the different factors that motivate you
14. Discuss the role of attitude in self-analysis
15. Discuss how to maintain a positive attitude
16. List your strengths and weaknesses
17. Discuss the qualities of honest people
18. Describe the importance of honesty in entrepreneurs
19. Discuss the elements of a strong work ethic
20. Discuss how to foster a good work ethic
21. List the characteristics of highly creative people
22. List the characteristics of highly innovative people
23. Discuss the benefits of time management
24. List the traits of effective time managers
25. Describe effective time management technique
26. Discuss the importance of anger management
27. Describe anger management strategies
28. Discuss tips for anger management
29. Discuss the causes of stress
30. Discuss the symptoms of stress
31. Discuss tips for stress management

UNIT 9.1.1: Health, Habits, Hygiene: What is Health?

Unit Objectives

At the end of this unit, participants will be able to:

- Explain the meaning of health
- List common health issues
- Discuss tips to prevent common health issues
- Explain the meaning of hygiene
- Discuss the purpose of Swachh Bharat Abhiyan
- Explain the meaning of habit

Resources to be Used

- Participant Handbook

Ask

- What do you understand by the term “Health?”
- According to you, who is a healthy person?

Say

- Discuss the meaning of health and a healthy person as given in the Participant Handbook.

Ask

- When did you visit the doctor last? Was it for you or for a family member?

Say

- Discuss the common health issues like common cold, allergies etc. Refer to the Participant Handbook.
- Let us do a small activity. I will need some volunteers.

Role Play

- Conduct a small skit with volunteers from the class. Consider one of the villagers has been appointed as a health representative of the village, what measures will you as a health representative suggest to the common villagers to prevent common health issues discussed.
- You will need at least 4 volunteers (Narrator, Health Representative, Head of the Village, Doctor).
- Explain the health concerns of the village to the Narrator. The Narrator will brief the class about the skit.
- Give the group of volunteers, 5 minutes to do discuss.
- At the end of 5 minutes, ask the group to present the skit to the class assuming them as the villagers.
- The class can ask questions to the group as a common villager.

Summarize

- Through this activity we got some tips on how can we prevent these common health issues.

Say 

- Let us now see how many of these health standards we follow in our daily life.

Activity 

- Health Standard Checklist from the Participant Handbook.

Ask 

- How many of you think that you are healthy? How many of you follow healthy habits?

Say 

- Let's do an exercise to find out how healthy you are.
- Open your Participant Handbook section 'Health, Habits, Hygiene: What is Health?', and read through the health standards given.
- Tick the points which you think are true for you.
- Try to be as honest as possible as this test is for your own learning.

Do 

- Ensure that all the participants have opened the right page in the Participant Handbook.
- Read aloud the points for the participants and explain if required.
- Give them 5 minutes to do the exercise.
- At the end of 5 minutes, ask the participants to check how many ticks have they got.

Summarize 

- Tell them that they need to follow all the tips given in this checklist regularly in order to remain healthy and fit.

Ask **Discuss:**

- Is it necessary to practice personal hygiene every day? Why?
- How does a person feel when they do not practice good personal hygiene? Why?
- Can good personal hygiene help a person feel good about his/her self? How?

Say 

- Discuss the meaning of hygiene as given in the Participant Handbook.

Activity 

- Health Standard Checklist: Hygiene

Say 

- Let's do an exercise to find out if we maintain good hygiene habits or not.
- Open the Participant Handbook and read through the Health Standard checklist given.
- Tick the points which you think are true for you.
- Try to be as honest as possible as this test is for your own learning.

Do 

- Ensure that all the participants have opened the right page in the Participant Handbook.
- Read aloud the points for the participants and explain if required.
- Give them 5 minutes to do the exercise. .
- At the end of 5 minutes, ask the participants to check how many ticks have they got.
- Ask them to calculate their score.
- Tell them what each score indicates by reading aloud what has been mentioned in the Participant Handbook.

Ask 

- How many of you have heard about “Swachh Bharat Abhiyan”?
- Can you tell the class what it is about?

Summarize 

- Tell them about Swachh Bharat Abhiyan as given in the Participant Handbook and request them to take a pledge to keep our country clean.

Ask 

- What is a habit?

Say 

- Discuss some good habits which can become a way of life.

Summarize 

- Tell them about good and bad habits and the reasons to make good habits a way of life.

UNIT 9.1.2: Safety

Unit Objectives

At the end of this unit, participants will be able to:

- Discuss ways to set up a safe work environment
- Discuss critical safety habits to be followed by employees

Resources to be Used

- Participant Handbook
- Safety signs and symbols
- Safety equipments
- Blank papers
- Pens

Say

- There are many common safety hazards present in most workplaces at one time or another. They include unsafe conditions that can cause injury, illness and death.
- Safety Hazards include:
 - Spills on floors or tripping hazards, such as blocked aisles or cords running across the floor.
 - Working from heights, including ladders, scaffolds, roofs, or any raised work area.
 - Unguarded machinery and moving machinery parts; guards removed or moving parts that a worker can accidentally touch.
 - Electrical hazards like cords, missing ground pins, improper wiring.
 - Machinery-related hazards (lockout/tag out, boiler safety, forklifts, etc.)

Team Activity

Safety Hazards

- There are two parts to this activity.
- First part will cover the potential safety hazards at work place.
- Second part will cover a few safety signs, symbols and equipments at work place.
- Use this format for the first part of the activity.

PART 1		
Hazard	What could happen?	How could it be corrected?

Ask

- How could you or your employees get hurt at work?

Say

- Let's understand it better with the help of an activity. You will be given a handout within your groups. You have to think about the possible hazards of your workplace, what damage these hazards could cause and about the corrective action.

Do

- Divide the class into five to six groups of four participants each.
- Put the format on the board for the activity.
- Give blank papers and pens to each group.
- The group is expected to think and discuss the potential safety hazards in the workplace.
- Ask the group to discuss and fill the format using the blank sheet.
- Give the groups 5 minutes for the activity.
- For the second part of the activity, show the class some pictures of safety signs, symbols and equipments.
- Now they will put down a few safety symbols, signs or equipment against the safety hazards identified.
- Give them 5 to 10 minutes to discuss and draw/note it.
- At the end of 10 minutes the groups will present their answers to the class.

Say

- Now, let's discuss the answers with the class.
- All the groups will briefly present their answers.

Do

- Ask the audience to applaud for the group presentation.
- Ask de-brief questions to cull out the information from each group.
- Keep a check on time.
- Tell the group to wind up the discussion quickly if they go beyond the given time limit.

Ask

De-briefing

- What did you learn from the exercise?
- As an entrepreneur, is it important to ensure the safety of your employees from possible hazards? Why?

Summarize

- Ask the participants what they have learnt so far.
- Ask if they have any questions related to what they have talked about so far.
- Close the discussion by summarizing the tips to design a safe workplace and non-negotiable employee safety habits.

UNIT 9.1.3: Self Analysis- Attitude, Achievement Motivation: What is Self Analysis?

Unit Objectives

At the end of this unit, participants will be able to:

- Explain the importance of self- analysis
- Discuss motivation with the help of Maslow's Hierarchy of Needs
- Discuss the meaning of achievement motivation
- List the characteristics of entrepreneurs with achievement motivation
- List the different factors that motivate you
- Discuss the role of attitude in self- analysis
- Discuss how to maintain a positive attitude
- List your strengths and weaknesses

Resources to be Used

- Participant Handbook
- Old newspapers
- Blank papers
- Pencils/ pens

Activity

- This is a paper pencil activity.

What are the three sentences that describe you the best?
--

What do you need to live happily?

What are your strengths and weaknesses?

Do

- Write the three questions on the board/ flipchart before the session begins.
- Give plain papers and pencils/ pens to each participant.
- Tell participants to write the answer for the three questions on the paper.
- Tell them the purpose of this activity is not to judge anyone but to understand more about self.

Say

- Discuss the concept of Self Analysis and motivation with reference to Maslow's Hierarchy of Needs as discussed in the Participant Handbook.

Team Activity

Tower building

- Each group which will create tower using the old newspapers.

Do 

- Divide the class into groups.
- Give them some old newspapers.
- The task is to create a tower out of the newspapers.
- The group which will create the highest tower standing on its own will be considered the winning group.
- Groups can use as many newspapers as they want to and in any way they want.

Ask 

- What did the winning group do differently?
- If you were given a chance, how would you have made the tower differently?
- How did you feel while making the tower?
- Did you feel motivated?

Say 

- Discuss the concept of achievement motivation and characteristics of entrepreneurs with achievement motivation as discussed in the Participant Handbook.

Ask 

- Is your attitude positive or negative?

Say 

- Let me tell you a story :

It's Little Things that Make a Big Difference.

There was a man taking a morning walk at the beach. He saw that along with the morning tide came hundreds of starfish and when the tide receded, they were left behind and with the morning sun rays, they would die. The tide was fresh and the starfish were alive. The man took a few steps, picked one and threw it into the water. He did that repeatedly. Right behind him there was another person who couldn't understand what this man was doing. He caught up with him and asked, "What are you doing? There are hundreds of starfish. How many can you help? What difference does it make?" This man did not reply, took two more steps, picked up another one, threw it into the water, and said, "It makes a difference to this one." What difference are we making? Big or small, it does not matter. If everyone made a small difference, we'd end up with a big difference, wouldn't we?

Ask 

- What did you learn from this story?

Activity **What Motivates You?**

- This is an individual activity.
- It is an exercise given in the Participant Handbook.

Do 

- Ask the class to open their Participant Handbook and complete the exercise given in the section What Motivates You?
- Ensure that the participants have opened the correct page for the activity.
- Give the class 5 minutes to complete the activity.

Say



- Discuss the concept of attitude and how to cultivate a positive attitude as discussed in the Participant Handbook.

Summarize



- Close the discussion by summarizing how self-analysis, knowledge about what motivates you and your positive attitude can help in your business as well in life.

UNIT 9.1.4: Honesty & Work Ethics

Unit Objectives

At the end of this unit, participants will be able to:

- Discuss the qualities of honest people
- Describe the importance of honesty in entrepreneurs
- Discuss the elements of a strong work ethic
- Discuss how to foster a good work ethic

Resources to be Used

- Participant Handbook

Ask

- What do you understand by honesty?
- Why is it important for entrepreneurs to be honest?
- Do you remember any incident where your honesty helped you in gaining confidence?
- Do you remember any incident where someone lost business due to dishonesty?

Say

- Talk about honesty, qualities of an honest person, and the importance of honesty in entrepreneurs as discussed in the Participant Handbook.
- “Let's understand it better with the help of some case scenarios. You will be given some cases within your groups. You have to analyse the case scenario that has been given to you and then find an appropriate solution to the problem.
- Keep your discussion focussed around the following:
 - What went wrong?
 - Who was at fault?
 - Whom did it impact- the customer or the businessman?
 - How would it impact the business immediately? What would be the long term impact?
 - What could be done?
 - What did you learn from the exercise?

Do

- Divide the class into four groups of maximum six participants depending on the batch size.
- Give one case study to each group.
- Instruct them to read the case carefully.
- Put down the de-brief questions on the board and ask the groups to focus their discussion around these questions.
- The group is expected to analyse and discuss the case amongst them and find a solution to the given problem. Give the class 5-10 minutes to discuss the case and note down their solutions.
- At the end of 10 minutes the team should present their case solution to the class. The presentation can be a narration or a role play.
- Ask the group to select a group leader for their group. The group leader to discuss and assign roles to the group members for the presentation.

Team Activity

Case Study Analysis

Scenario 1

Aakash has a small mobile retail sales and repair shop in Allahabad. He has one of the most popular outlets and has great rapport with his customers.

It's around 11 AM when a customer barges in to the shop and starts shouting at Aakash for giving her a faulty instrument. The screen of her mobile is cracked from one side. Aakash remembered thoroughly checking the handset before handing it over to the customer. The customer threatens to sue him and to go to Consumer Court for cheating her. Now, the problem occurred somewhere outside the shop but as other customers were listening to the conversation, it might impact his business. The situation needs to be managed very sensitively. What would you do if you were in Aakash's place?

Scenario 2

Rajni does beautiful Phulkari embroidery on suits and sarees. She has a small home-based business. She has a huge list of customers on Facebook and WhatsApp who give her orders regularly. Smita is one of her old and regular customers. As her sister-in-law's wedding was around the corner, Smita wanted to buy few handcrafted Phulkari duppatta. She placed an order for three duppattas via WhatsApp and requested Rajni to send them as soon as possible. When the parcel reached Smita through courier she found that out of the three duppattas, only one was hand embroidered and the other two had machine embroidery on them. Even the length and the quality of the material was not as desired. Smita was heartbroken. It was a complete waste of money and moreover she couldn't wear what she had planned to during the wedding functions. She sent a message to Rajni on WhatsApp, expressing her anger and disappointment.

Smita has also sent a feedback and expressed her disappointment on the social media... this will directly affect Rajni's business. What would you do if you were in Rajni's place?

Scenario 3

Shankar is a tattoo artist who has a small tattoo showroom in a big, reputed mall in New Delhi. Mr Saksham had an appointment for today, at 11:00 am but he reached at 11:50 am. Meanwhile, Shankar had to reschedule his next appointment. After availing Shankar's services, Mr Saksham started yelling in an abusive language, refusing to pay the requisite amount, and finding faults in the services provided by him. Who was at fault in this case? What should Shankar do? Should he confront Saksham or give in to the demands of the client?

Scenario 4

Shailender is an online cloth reseller who does business through social networking sites such as Facebook and WhatsApp. Priyanka made online payment for a dress to Shailender. But she did not receive the dress for a month. When she asked for a cancellation, Shailender started misleading her. For almost 45 days, he kept promising her that he will pay the amount today, tomorrow, day after etc. Even after repeated calls and messages when she did not receive the payment or the dress, she decided to write a post against him on a popular social media platform. As a result, Shailender lost lots of customers and his flourishing business faced a major crisis. How could this situation have been managed?

Say

- Now, let's discuss the problem and solution with the larger group.
- The group will first briefly describe the case to the class.
- Then discuss the issue identified and the proposed solution.
- Once the presentation is over, the class can ask their questions.

Do 

- Congratulate each group for the group presentation.
- Ask the audience to applaud for them.
- Ask de-brief questions to cull out the information from each group.
- Keep a check on time. Tell the group to wind up the discussion quickly if they go beyond the given time limit.

Summarize 

- Ask the participants what they have learnt from the exercise/ activity.
- Ask if they have any questions related to what they have talked about so far.
- Close the discussion by summarizing the importance of honesty and work ethics for entrepreneurs.

UNIT 9.1.5: Creativity and Innovation

Unit Objectives

At the end of this unit, participants will be able to:

- List the characteristics of highly creative people
- List the characteristics of highly innovative people

Resources to be Used

- Participant Handbook
- Chart papers
- Marker pens

Ask

- You must be aware of the term 'Rags to riches' and heard stories related to the term.
- What do these stories tell us?
- What was so special about these people?

Say

- Let's have a look at these stories.
- There are some inspiring stories about people which I would like to share with you.
- Narrate these stories to the class.

A.P.J. Abdul Kalam

Who has not heard of A.P.J. Abdul Kalam: Avul Pakir Jainulabdeen Abdul Kalam hailed from a very humble background. His father was a boat owner. To help his family, Kalam would work as a newspaper vendor. With limited resources, he graduated in Physics and studied aerospace engineering. He was instrumental in India's step towards nuclear energy. In 2002, he became the 11th President of India.

Water filter/purifier at source

Two young boys studying in classes 4 and 5, from Lingzya Junior High School, Sikkim designed a simple innovative low cost water purifier.

Inspiration behind the idea: Most people today prefer to use a water filter/purifier at their home.

Both the children have given idea to have filter/purifier at the source of water so that everyone has access to clean water without having to make an investment in purchasing a filter/purifier.

Spring's idea is to have a centralised purification system at the point of distribution like water tank while Subash's idea is to have such purifiers attached to public taps.

Source: <http://www.rediff.com/getahead/report/achievers-top-31-amazing-innovations-from-young-indians/20151208.htm>

Solar seeder

This is a story of a innovative solar seeder and developed by Subash Chandra Bose, a class 8, student from St Sebastiyar Matriculation School, Pudukkottai, Tamil Nadu. Subash has developed a solar powered seed drill, which can undertake plantation for different size of seeds at variable depth and space between two seeds.

Source: <http://www.rediff.com/getahead/report/achievers-top-31-amazing-innovations-from-young-indians/20151208.htm>

Looms for physically challenged

Now this is really inspiring of two sisters, Elakkiya a Class 6 student and Pavithra a Class 9 student of SRC Memorial Matriculation, Erode, Tamil Nadu.

The two sisters have come up with loom for lower limbed physically challenged. In their loom they have replaced the pedal operated system with a motor and a gearbox attached to a pulley mechanism.

Source: <http://www.rediff.com/getahead/report/achievers-top-31-amazing-innovations-from-young-indians/20151208.htm>

Ask 

- If they can, why can't you?
- Discuss concepts related to 'Creativity and Innovation' with the participants as given in the Participant Handbook.

Say 

- Recall the stories on motivation.
- What is the inner drive that motivates people to succeed?
- Let's learn more about such creative and innovative entrepreneurs with the help of an activity.

Team Activity 

- This is a group activity.

- Think of any one famous entrepreneur and write a few lines about him or her.

Activity De-brief

- Why did you choose this particular entrepreneur?
- What is his/her brand name?
- What creativity does he/she possess?
- What was innovative about their ideas?

Do 

- Instruct the participants that this is group work.
- Divide the class into small groups of 4 or 6 depending on the batch size.
- Give each group a chart paper.
- Tell the participants they have to write a few lines about any one famous entrepreneur.
- Give the participants 10 minutes to discuss and write.
- Keep a check on time. Tell the group to wind up quickly if they go beyond the given time limit.
- Ask each group to read out what they have written.
- Ask the de-brief questions.

Summarize

- Summarize the unit by asking participants if they know of some people who are highly creative and innovative in their approach.
- Ask them to share some experiences about these people with the class.

Notes for Facilitation

- Source for stories on innovations:

<http://www.rediff.com/getahead/report/achievers-top-31-amazing-innovations-from-young-indians/20151208.htm>

UNIT 9.1.6: Time Management

Unit Objectives

At the end of this unit, participants will be able to:

- Discuss the benefits of time management
- List the traits of effective time managers
- Describe effective time management techniques

Resources to be Used

- Participant Handbook

Ask

Does this sound like you?

- I can never get enough time to finish what I am doing in a day.
- I have so many things to do that I get confused.
- I want to go for a walk and exercise, but I just do not have the time.
- I had so much to do, so I could not deliver that order on time.
- I would love to start my dream business; but, I just do not have the time.

Example

- Let's look at these two examples:

Example 1:

Ankita works from home as a freelance writer. She says she can easily put in 8 hours of dedicated work in a day. Because she works from home, she saves money on travel and has a comfortable work routine. But there is a challenge and it is distraction. As she works from home, she can easily just get up and sit down on the sofa to watch TV, wasting valuable time. She may have chores to do, errands to run and bills to pay. She ends up working only two to three hours a day and the result is, her work gets piled up. She is unable to take on more work due to this. Even though her quality of work is appreciated her clients are not very happy about the delay in submission.

Example 2:

Javed has started a successful online selling company from home and makes a good living from his sales. He has set up a small office space in his living room. As both his parents are working full-time, he also has the role of taking care of his two younger siblings. He almost spends half of his day with the younger kids. He does not mind it but it means taking time away from the work. He is still able to manage his online business with these commitments. He wants to spend some more dedicated hours so as to increase his profits. He also wants to look into new business avenues. What should he be doing.

Ask

- Does this happen with you too?
- Do you find it difficult to prioritize your work?
- Are you able to manage your time effectively?

Activity



- Conduct a group discussion based on the above examples.
- Direct the discussion on how to prioritize work and manage time effectively.

Say



- Time management is not only about how hard you work but also about how smart you work.
- Discuss “What is Time Management” with the participants as given in the Participant Handbook.

Ask



- Why is it important to manage time? How does it help?
- What happens when you don't manage your time effectively?
- Do you find it difficult to prioritize your work?

Say



- Discuss the benefits of time management given in the Participant Handbook.
- Let's learn effective time management with the help of an activity.

Activity



Effective Time Management

- This activity has two parts:

PART 1 TO-DO LIST

- You have to make a to-do list.
- List all of the activities/ tasks that you have to do.
- Try to include everything that takes up your time, however unimportant it may be.
- If they are large tasks, break them into action steps, and write this down with the larger task.
- You can make one list for all your tasks or have separate to-do lists for personal and professional tasks.

PART 2 URGENT-IMPORTANT GRID

- You have to make a grid as shown on the board here. .
- This grid has four boxes. As you can see, each box has a different heading.
- At the heart of the urgent-important grid, are these two questions:
 - ♦ Is this task important?
 - ♦ Is this task urgent?
- Now, you have to think about each activity that you have written in your to-do list and put it into one of the four categories.
- **What do these categories depict?**
- **Category 1: Urgent/Important**
 - ♦ This category is for the highest priority tasks. They need to get done now.

- **Category 2: Not Urgent/Important**
 - This is where you want to spend most of your time.
 - This category allows you to work on something important and have the time to do it properly.
 - This will help you produce high quality work in an efficient manner.
 - The tasks in this category are probably the most neglected ones, but also the most crucial ones for success.
 - The tasks in this category can include strategic thinking, deciding on goals or general direction and planning – all vital parts of running a successful business.
- **Category 3: Urgent/Not Important**
 - This is where you are busy but not productive. These tasks are often mistaken to be important, when they're most often busywork.
 - Urgent but not important tasks are things that prevent you from achieving your goals.
 - However, some may be activities that other people want you to do.
- **Category 4: Not Important and Not Urgent**
 - This category doesn't really include tasks, but rather habits that provide comfort, and a refuge from being disciplined and rigorous with your time management.
 - Some may be activities that other people want you to do.
 - These might include unplanned leisure activities as well.

TO- DO list format

1.	
2.	
3.	
4.	
5.	
6.	
7.	
8.	
9.	
10.	
11.	
12.	
13.	
14.	
15.	

URGENT-IMPORTANT GRID

URGENT/ IMPORTANT

- Meetings
- Last minute demands
- Project deadlines
- Crisis

NOT URGENT/ IMPORTANT

- Planning
- Working towards goals
- Building relationship
- Personal commitments

1

2

3

4

- Interruptions
- Phone calls/ E-mails
- Other people's minor demands

URGENT/ NOT IMPORTANT

- Internet surfing
- Social media
- Watching TV

NOT URGENT/ NOT IMPORTANT

URGENT/ IMPORTANT GRID format

URGENT/ IMPORTANT

NOT URGENT/ IMPORTANT

1

2

3

4

URGENT/ NOT IMPORTANT

NOT URGENT/ NOT IMPORTANT

Do

- Put down the formats for the to-do list and the urgent/important grid on the board.
- Instruct the participants to prepare their to-do list first.
- Give the participants 10 minutes to prepare the list.
- Once done, instruct them to divide the tasks in to-do list into the four categories.
- Explain the four categories to the participants giving examples specific to their context.
- As you explain the categories fill the grid with the type of tasks.
- Give the participants 40 minutes to fill the grid.
- Then explain how to balance the tasks between the four categories.
- Keep a check on time. Tell the group to wind up quickly if they go beyond the given time limit.

Say

Activity De-brief:

How can we balance tasks between the four categories?

How to manage time through this grid?

- **Category 1: Urgent/Important**
 - ♦ Try to keep as few tasks as possible here, with the aim to eliminate.
 - ♦ If you spend too much of your time in this category, you are working solely as a trouble shooter, and never finding time to work on longer-term plans.
- **Category 2: Not Urgent/Important**
 - ♦ Plan these tasks carefully and efficiently as they are most crucial ones for success.
 - ♦ If necessary, also plan where you will do these tasks, so that you're free from interruptions.
 - ♦ Include strategic thinking, deciding on goals or general direction and planning in your planning process.
- **Category 3: Urgent/Not Important**
 - ♦ Ask yourself whether you can reschedule or delegate them.
 - ♦ A common source of such activities is other people. Sometimes it's appropriate to say "no" to people politely, or to encourage them to solve the problem themselves.
- **Category 4: Not Important and Not Urgent**
 - ♦ You also want to minimize the tasks that you have in this category.
 - ♦ These activities are just a distraction – avoid them if possible.
 - ♦ You can simply ignore or cancel many of them.
 - ♦ Politely say "no" to work assigned by others, if you can, and explain why you cannot do it.
 - ♦ Schedule your leisure activities carefully so that they don't have an impact on other important tasks.
- Discuss the traits of effective time managers and effective time management techniques as given in the Participant Handbook.

Summarize

- Discuss the traits of effective time managers and effective time management techniques as given in the Participant Handbook.

Notes for Facilitation



- Here is a short story. You can conclude the session narrating the story. To make it more interesting you can perform the demonstration described and discuss the short story.
 - ♦ One day an expert in time management was speaking to a group of students. As he stood in front of the group, he pulled out a large wide-mouthed glass jar and set it on the table in front of him. Then he took out a bag of about a dozen rocks and placed them, one at a time, into the jar. When the jar was filled to the top and no more rocks would fit inside, he asked, "Is this jar full?" Everyone in the class said, "Yes." Then he said, "Really?"
 - ♦ He reached under the table and pulled out a bucket of gravel (small stones). He dumped some gravel in and shook the jar causing pieces of gravel to work themselves down into the space between the rocks. Then he asked the group once more, "Is the jar full?" By this time, the class began to understand. "Probably not," one of them answered. "Good!" he replied.
 - ♦ He reached under the table and brought out a bucket of sand. He started dumping the sand in the jar and it went into all of the spaces left between the rocks and the gravel. Once more he asked the question, "Is this jar full?" "No!" the class shouted. Once again he said, "Good." Then he grabbed a jug of water and began to pour it in until the jar was filled to the brim. Then he looked at the class and asked, "What is the point of this illustration?" "One student raised his hand and said, "No matter how full your schedule is, if you try really hard you can always fit some more things in it!" "No," the speaker replied, "that's not the point. The truth this illustration teaches us is: If you don't put the big rocks in first, you'll never get them in at all." What are the 'big rocks' in your life? Your children; your loved ones; your education; your dreams; a worthy cause; teaching or mentoring others; doing things that you love; time for yourself; your health; your mate (or significant other). Remember to put these BIG ROCKS in first or you'll never get them in at all. If you sweat about the little stuff (the gravel, sand, and water) then you'll fill your life with little things you worry about that don't really matter, and you'll never have the time you need to spend on the big, important stuff (the big rocks).
- End the story with these lines...

So, tonight, or in the morning tomorrow, when you are reflecting on this short story, ask yourself this question: What are the 'big rocks' in my life? Then, put those in your jar first

UNIT 9.1.7: Anger Management

Unit Objectives

At the end of this unit, participants will be able to:

- Discuss the importance of anger management
- Describe anger management strategies
- Discuss tips for anger management

Resources to be Used

- Participant Handbook

Ask

- What is anger? Is anger good or bad?
- Is anger normal or an abnormal behaviour? How can anger harm you?
- Why is it important for entrepreneurs to manage their anger?

Say

- Talk about anger and the importance of anger management in entrepreneurs as discussed in the Participant Handbook.
- Let us do a small activity. This is an individual activity.
- Think of the incidents and situations that angered you and hurt you.

Do

- Instruct them to note down these situations under different categories (as given in the Activity).
- Give the class 3-5 minutes to think and note down their answers.
- At the end of 5 minutes, ask some participants to volunteer and present their answers.
- They can also share these situations with their fellow participants if they do not wish to share it with the entire class.

Activity

- Do you remember any incident which has hurt
 - ♦ you physically
 - ♦ you mentally
 - ♦ your career
 - ♦ your relationships.

Ask

- Do you ever get angry?
- What are the things that make you angry?
- Do you remember any incident where your anger management helped you in maintaining healthy relationship?
- Do you remember any incident where someone lost business/ friend/ relationship due to temper (anger)?

Say 

- There are a few strategies which can help in controlling your anger. Let's do an activity to understand the anger management process better.
- This is an individual activity.
- Think of the incidents/ situations which trigger your anger (the cause).
- Then think what happened as a result of your anger (the effect).
- You need to come up with some techniques to manage your anger.

Do 

- Give the class the anger triggers (the cause) as listed in the activity.
- Put down the activity format (Anger Triggers, Result of your Anger, Anger Management Techniques) on the board and instruct the class to write the answers under different categories.
- Give the class 3-5 minutes to think and note down their answers.
- At the end of 5 minutes, ask the participants who wish to volunteer and present their answers.

Activity 

Trigger points and Anger Management Techniques Activity

Anger Triggers

List of triggers that make you angry:
Someone says you did something wrong.
You want something you can't have now.
You get caught doing something you shouldn't have been doing.
You are accused of doing something you didn't do.
You are told that you can't do something.
Someone doesn't agree with you.
Someone doesn't do what you tell him to do.
Someone unexpected happens that messes up your schedule.

Result of your anger:

Write the techniques that you use to manage your anger:

Anger Management Techniques

Say

- Now, let's discuss the problems and solution with all.
- The individual will first briefly describe trigger points to the class.
- Then discuss the result of the anger. Other participants are requested to remain quiet while one is making the presentation.
- Post presentation, other participants may ask questions.

Do

- Congratulate each individual for sharing their points.
- Ask the audience to applaud for them.
- Ask de-brief questions after the presentation to the class.
- Keep a check on the time. Ask the participants to wind up the activity quickly if they go beyond the given time limit.

Ask

De-brief questions:

- In the situation described by the presenter, who was at fault?
- How could you have handled this situation alternatively?

Summarize

- Close the discussion by summarizing the strategies and tips of anger management for entrepreneurs.
- Ask the participants what have they learnt from this exercise/ activity.
- Ask if they have any questions related to what they have talked about so far.

Notes for Facilitation

- Encourage the participants to share information about them while presenting the situations to the class.
- Keep the format of the Activity prepared in a chart paper so that it can be displayed during the session.

UNIT 9.1.8: Stress Management: What is stress?

Unit Objectives

At the end of this unit, participants will be able to:

- Discuss the causes of stress
- Discuss the symptoms of stress
- Discuss tips for stress management

Resources to be Used

- Participant Handbook

Ask

- You are waiting in the reception for an interview or a very important meeting, suddenly your legs are shaky, your hands are cold, you are feeling nervous. Have you ever been in this kind of situation?
- Have you had days when you had trouble sleeping?
- Have you ever been so worried about something that you ended up with a terrible headache?

Say

- You've probably heard people say, "I'm really stressed out" or "This is making me totally stressed."

Ask

- What do you understand by stress?
- What gives you stress?
- How do you feel when you are stressed or what are the symptoms of stress?
- How can stress harm you?
- Why is it important for entrepreneurs to manage stress?

Say

- When we feel overloaded or unsure of our ability to deal with certain challenges, we feel stressed.
- Discuss about stress, causes of stress, and symptoms of stress as discussed in the Participant Handbook.
- Let's understand the causes of stress and how to deal with them with the help of some case scenarios.
- You will be given some cases.
- You have to analyse the case scenario and then find an appropriate solution to the problem.
- This will be a group activity.

Do

- Divide the class into four groups of 5-6 participants (depending on the batch size).
- Assign one case scenario to each group.
- Instruct them to read the case carefully.
- The group is expected to analyse and discuss the case amongst them and find a solution to the given problem.
- Explain their discussion should result in getting answers for the following questions:

- ♦ What was/ were the cause(s) of stress?
- ♦ Was the stress avoidable or manageable under the given circumstances?
- ♦ If yes, how do you think that the stress could be avoided (managed)?
- ♦ If no, then why not?
- Give the class 10-12 minutes to discuss the case and note down their solutions.
- At the end of 12 minutes, the team should present their case solution to the larger group.
- Ask the group to select a group leader for their group.
- The group leader to discuss and assign roles to the group members for the presentation.

Team Activity



Case Study Analysis

Scenario 1

Akash's alarm doesn't go off and he gets late getting out of the house. He hits traffic and ends up 15 minutes late to work, which his boss notices. He gets to his desk and finds he has to complete 2 reports in next one hour. Just when he is about to begin work, a message pops up "Telecon with the client begins in 10 minutes. Please be in the conference room in 5 minutes."

His is not prepared for the call. He is stressed. He does not want to speak to his boss about this. He is stressed, feeling uncomfortable and sick. Not in a position to attend the call or finish the reports on time.

Scenario 2

While paying his overdue bills, Rahul realised that it's the middle of the month and he has only Rs 500 left in his account. He has already asked all of his friends, and family for loans, which he hasn't paid back yet. He is still contemplating over the issue when his phone rings. His sister's birthday is due next week and she has seen a beautiful dress which she wants to buy but cannot tell the parents as it is a bit expensive. She wishes if Rahul could buy the dress for her. Rahul has promised to buy her the dress for her birthday.

Rahul is stressed, does not understand what to do. He is unable to concentrate on his work and unable to complete the tasks assigned. His team leader has already warned him of the delay.

Scenario 3

Sheela calls the cable company as she has unknown charges on her bill. She has to go through the automated voice mail menu three times and still can't get through to a customer care executive. After 15 minutes of repeated efforts, her call is answered. She explains the entire issue to the customer care executive but before the person could suggest a way out, the call drops.

Now Sheela has to call back and repeat the whole process all over again with a new customer care executive. She is very angry and calls again but cannot connect this time.

She has to leave to office so she decides to call from office and check. When she connects this time she is angry and argues with the executive on the call. All her co-workers around are looking at her as her volume has suddenly increased. She bangs the phone and ends the call.

Her co-worker Neelam enquires what has happened to her. She ignores her and just walks off. She has become irritable and her behaviour and tone with other co-workers is not acceptable.

Scenario 4

Arpit is a young entrepreneur who started doing business through Facebook few weeks back. He had always been into a job. Although Arpit has very few financial liabilities, it wasn't an easy decision to leave a comfortable job at once and look for newer pastures. Arpit's boss warned him of the consequences and the challenges of starting a business when nobody ever in his family had been in business.

He has not been able to get a good deal till now. This is an important life shift for him which comes with unknown variables. Arpit is nervous and is wondering if he has what it takes to fulfill the requirement of his new role, or the new experiences he's likely to face.

Ask**De-brief questions:**

- What was/ were the cause(s) of stress?
- Was the stress avoidable or manageable under the given circumstances?
- If yes, how do you think that the stress could be avoided (managed)?
- If no, then why not?

Say

- Now, let's discuss the problem and solution with the larger group.
- The group will first briefly describe the case to the class.
- Then discuss the issue identified and the proposed solution.
- Post presentation, the other groups may ask questions to the group that has presented.

Do

- Congratulate each group for sharing their points.
- Ask the audience to applaud for them.
- Ask de-brief questions to cull out the information from each group.
- Keep a check on time. Tell participants to wind up the discussion quickly if they go beyond the given time limit.

Say

- While it is common and normal to feel some tension. This feeling nervous and tensed can interfere with your thinking process and can have a negative impact on your performance.
- Stress can deplete the most vibrant of souls. It can have a negative effect on every aspect of a person's life including their health, emotional well-being, relationships, and career. However, one needs to understand the causes and types of stress before looking for ways to manage it.

De-brief:**Scenario 1**

The cause of stress was lack of time management and the habit of procrastinating. If Akash would have managed his time well, planned alternate ways to get up on time, finished prior tasks on time and planned for client meetings in advance then he wouldn't have faced stress.

Scenario 2

The cause of stress was lack of financial planning. Rahul should have planned his financial resources well in advance and saved some money for the rainy day. Also, differentiating between needs and wants and keeping a check on non-essential expenditure would have saved Rahul from this situation.

Scenario 3

Sometimes, stress is caused due to external factors instead of internal ones. In this case, the stress was unavoidable because we have no control over this customer care system. Every time, you will get in touch with a new executive and will have to explain all over again. This might cause stress but despite being frustrated and angry there is little that we can do about it. All Sheela could do was to find ways to calm herself down through some breathing exercises and meditation, reading some good book or listening to music and then start afresh.

Scenario 4

A positive, major life change can be a source of good stress. Regardless of how good the change is, it can be stressful. Stress caused by a positive and major life change can be beneficial because it causes a person to step out of their comfort zone and learn new skills. Here, Arpit may become a successful entrepreneur or learn new ways to do things differently.

Now let us see this scenario, can I have a volunteer to read out this case to the class.

Do 

- Ask one of the participant who can volunteer and read out this scenario to the class.

Scenario 5

Rakesh lives in Kathmandu with his wife and two beautiful daughters Sarah and Sanya. Nepal was hit by a massive earthquake and Rakesh's building collapsed during the earthquake. During evacuation, Rakesh realised that though his wife and Sarah were fine and suffered only minor bruises, Sanya was nowhere in the scene. Panic stricken, he started calling her name and searching her frantically. A little later, he heard a meek voice from beneath the debris. He quickly removed the rubble to find a huge bed. Rakesh was pretty sure that Sanya was trapped underneath. Though he was badly bruised, he gathered all his courage and with all his might, he lifted the several-ton bed to save Sanya's life. Everyone was relieved to see Sanya alive and also extremely surprised to see this father's ability to access superhuman strength.

- Ask the audience to applaud for the participant after the scenario is read completely.
- Discuss the scenario, ask de-brief questions:
 - ♦ What kind of stress was Rakesh undergoing in this case?
 - ♦ Was the stress avoidable or manageable under the given circumstances?
 - ♦ What was the result of the stress?

Say **De-brief:**

- Not all stress is harmful; good stress is actually energizing. This was a case of lifesaving stress, or hero stress, which is an important example of good stress. You may have heard stories in which a person performs an impossible feat of physical strength in order to save their life or the life of someone they love. This type of stress causing a surge of adrenaline is good for us.

Summarize

- Close the discussion by summarizing the tips to manage stress as given in the Participant Handbook.
- Ask the participants what they have learnt from this exercise/ activity.
- Ask if they have any questions related to what they have talked about so far.

Notes for Facilitation

- Keep printed copies of the activities/ scenarios ready for the session.
- Put down the de-brief questions on a flip chart so that it can be displayed in the class during the activity.
- Encourage participation and make the discussions interactive.

UNIT 9.2: Digital Literacy: A Recap

Key Learning Outcomes



At the end of this unit, participants will be able to:

1. Identify the basic parts of a computer
2. Identify the basic parts of a keyboard
3. Recall basic computer terminology
4. Recall the functions of basic computer keys
5. Discuss the main applications of MS Office
6. Discuss the benefits of Microsoft Outlook
7. Identify different types of e-commerce
8. List the benefits of e-commerce for retailers and customers
9. Discuss Digital India campaign will help boost e-commerce in India
10. Describe how you will sell a product or service on an e-commerce platform

UNIT 9.2.1: Computer and Internet Basics: Basic Parts of a Computer

Unit Objectives

At the end of this unit, participants will be able to:

- Identify the basic parts of a computer
- Identify the basic parts of a keyboard
- Recall basic computer terminology
- Recall the functions of basic computer keys

Resources to be Used

- Participant Handbook
- Computer Systems with the required applications

Say

- Let's take a quick recap of the basic computer parts.
- Discuss 'Basic Parts of Computer' and 'Basic Parts of a Keyboard' with the class as given in the Participant Handbook.

Explain

- Explain all the parts of the computer and the keyboard by demonstrating on the real system.

Ask

- Do you know about internet?
- Have you ever used internet?
- Why do you think internet is useful?
- What was the last task you performed on internet?

Say

- Let's look at some basic internet terms.
- Discuss 'Basic Internet Terms' with the participants as given in the Participant Handbook.

Summarize

- Ask the participants what they have learnt from this exercise/ activity.
- Ask if they have any questions related to what they have talked about so far.
- Close the discussion by summarizing the importance of computer and internet for entrepreneurs.

Practical

- Conduct a practical session.
- Ask the participants to assemble in the computer lab.
- Give some hands on practice exercises.

Do

- Group the participants for the activity depending on the batch size and the number of computer systems available in the lab.
- Explain the purpose and duration of the activity.
- Ensure the participants complete the practical exercises assigned.

UNIT 9.2.2: MS Office and Email: About MS Office

Unit Objectives

At the end of this unit, participants will be able to:

- Discuss the main applications of MS Office
- Discuss the benefits of Microsoft Outlook

Resources to be Used

- Participant Handbook
- Computer Systems with MS Office

Ask

- What is the most frequent activity that you do on the computer?
- Do you know how to make presentations on the computer?

Say

- Give a brief introduction of MS Office as given in the Participant Handbook.
- Discuss the most popular office products. Explain in brief their application, benefits and working.
- **Microsoft Word** is a word processing program that allows for the creation of documents. The program is equipped with templates for quick formatting. There are also features that allow you to add graphics, tables, etc.
- **Microsoft Excel** is a tool for accounting and managing large sets of data. It can also simplify analysing data. It is also used to create charts based from data, and perform complex calculations. A Cell is an individual data box which will have a corresponding Column and Row heading. This gives the cell a name, referred to as the Cell Reference. There can be multiple pages in each workbook. Each page, or sheet, is called a Worksheet. When you open a new Excel file, it automatically starts you with three worksheets, but you can add more.

Explain

- Explain the working and frequently used features of Office on a real system.

Ask

- What do you know about e-mails?
- Do you have an email id?
- How often do you check your e-mails?

Say

- Communication is vital for every business. The fastest and the safest way to communicate these days are through emails. MS Outlook helps to manage your emails in a better way and also offers a host of other benefits.
- Discuss “Why Choose Microsoft Outlook?” with the participants as given in the Participant Handbook.

Do 

- Ask the participants to assemble in the computer lab.
- Explain the working of Outlook on a real system..

Demonstrate 

- Demonstrate how to create email id.
- Demonstrate how to write new mails, send mails.
- Demonstrate how to use MS Office application to create a letter and send it as attachment in an email.
- Demonstrate how to use other MS Office applications.

Practical 

- Give some hands on practice exercises
- Group the participants for the activity depending on the batch size and the number of computer systems available in the lab.
- Explain the purpose and duration of the activity.

Summarize 

- Ask the participants what they have learnt from this exercise/ activity.
- Ask if they have any questions related to what they have talked about so far.

UNIT 9.2.3: E-Commerce

Unit Objectives

At the end of this unit, participants will be able to:

- Identify different types of e-commerce
- List the benefits of e-commerce for retailers and customers
- Discuss Digital India campaign will help boost e-commerce in India
- Describe how you will sell a product or service on an e-commerce platform

Resources to be Used

- Computer System with internet connection
- Participant Handbook

Ask

- How many of you have done shopping online?
- Can you name at least five shopping websites?
- What is the product that you most frequently buy online?
- Why do you do shopping online instead of going to the market?

Say

- Give a brief introduction of “What is E-commerce”. Refer to the Participant Handbook.
- E-commerce emerged in the early 1990s, and its use has increased at a rapid rate. Today, many companies sell their products online. Everything from food, clothes, entertainment, furniture and many other items can be purchased online.

Ask

- What other types of transactions have you performed on the internet other than buying products?

Say

- Give examples of e-commerce activities from Participant Handbook.

Team Activity

E-commerce examples

- Instruct the participants to list some of the payment gateways that they have used for e-commerce activities.
- Give them 5 minutes to make this list.
- Discuss payment gateways and transaction through payment gateways.
- Conclude the discussion by mentioning how important e-commerce has become in our day to day transactions.

Say

- E-commerce activities can be classified based on the types of participants in the transaction.
- Discuss “Types of E-commerce” from the Participant Handbook.

Do

- Discuss all types of E-commerce by giving examples and names of some popular websites which use them.
- Make the discussion interactive by asking the class to share some popular e-commerce sites of each type.

Say

- E-commerce activities bring a host of benefits for both, retailers and customers.
- Discuss benefits of E-commerce from the Participant Handbook.

Explain

- The majority of the population that uses E-commerce activities lives in tier-1 and tier-2 cities. To encourage the use of digital money in tier-3 and 4 areas, PM Mr. Modi launched the “Digital India Campaign”.
- Discuss “Digital India Campaign” from the Participant Handbook.
- By Digital India project the government will deliver services via mobile connectivity and in doing so, is expected to bring the internet and broadband to remote corners of the country. This connectivity will in turn enhance e-commerce activities also. Furthermore, the Indian Government is also modernizing India Post and aims to develop it as a distribution channel for e-commerce related services.

Say

- Now let us discuss how to sell a product using E-commerce.
- Every product has to be sold on a platform on the internet. Think of it as a shop that you have to sell your product. Now this shop can be your own or shared or rented. If the shop is your own or rented there will be only your products in that shop. If the shop is shared, there will be products of multiple sellers in that shop. A common example is a departmental store which has products from multiple brands in the shop.
- Similarly, in E-commerce the shop is the website where your products are displayed. If it is your own website it will exclusively showcase your products. In this case the cost that you will incur will be:
 - Developing the website
 - Hosting the website
 - Maintenance of the website
- If you rent a website it will also showcase your own products but the development, hosting and maintenance parts goes to the owner. This saves time and the cost to manage these activities.
- Smaller companies usually go for renting a website and the bigger ones develop their own website.
- The concept of shared platforms has become very popular in recent times. In this platform the sellers have to register and then they can sell their goods on a common platform. Among the most popular of these are Amazon, Myntra, Flipkart, etc.

Role Play

- Tell the participants to choose a product or service that they want to sell online.
- Tell them to write a brief note explaining how they will use existing e-commerce platforms, or create a new e-commerce platform to sell their product or service.

Ask 

- How much money are you carrying in your wallet?
- Do you have a credit/debit card?
- How do you make payments while doing online shopping?

Say 

- Demonetization has made carrying cash in the wallet very difficult. People either shop through cards or some other form of digital money.
- So what do you think is digital money?
- In this form the money is both paid and received digitally. There is no hard cash involved. It is an instant and convenient way to make payments.
- There are various types of digital payments. Let us discuss some of them in brief here.
- The first one is the most commonly used system i.e. the cards. Debit card, credit card, prepaid card, all fall under this category.
- Then is the e-wallet or the mobile wallet. This has become the most used form of digital money after demonetization. Examples are Paytm, state bank buddy, Freecharge, etc.
- Many other forms of digital money are also coming up in market like mobile apps, Aadhar card based payment, etc.

Do 

- Demonstrate how to make and receive payments through digital models like Paytm and state bank buddy.

Ask 

- Why do you think people have started using digital money instead of hard cash? Is demonetization the only reason?

Say 

- Digital money gives a lot of advantages over the conventional hard cash. Some of them are:
 - ♦ Digital payments are easy and convenient. You do not need to take loads of cash with you, a mobile phone or a card will suffice.
 - ♦ With digital payment modes, you can pay from anywhere anytime.
 - ♦ Digital payments have less risk.

Summarize 

- Ask the participants what they have learnt from this exercise/ activity.
- Ask if they have any questions related to what they have talked about so far.
- Close the discussion by summarizing the importance of e-commerce and digital money.

UNIT 9.3: Money Matters

Key Learning Outcomes



At the end of this unit, participants will be able to:

1. Discuss the importance of saving money
2. Discuss the benefits of saving money
3. Discuss the main types of bank accounts
4. Describe the process of opening a bank account
5. Differentiate between fixed and variable costs
6. Describe the main types of investment options
7. Describe the different types of insurance products
8. Describe the different types of taxes
9. Discuss the uses of online banking
10. Discuss the main types of electronic funds transfer

UNIT 9.3.1: Personal Finance – Why to Save?

Unit Objectives

At the end of this unit, participants will be able to:

- Discuss the importance of saving money
- Discuss the benefits of saving money

Resources to be Used

- Participant Handbook

Ask

- How many of you save money?
- Why do you feel the need to save it?
- Do you plan your savings?
- Where do you keep the money you save?
- How do you use the money that you have saved?

Example

- Let's look at these two examples:

Example 1:

Suhani works in a good company and earns Rs.30,000 month. She always saves 5000 per month and keeps it aside as a personal saving. She keeps the money at home and has saved quite a lot. One day her mother has a medical emergency and has to be taken to the hospital. Her family is worried about the amount they have to spend for the treatment. It will cost them atleast 40,000.

Suhani says tells her family not to worry and that she has about 50,000, which she has saved over the months.

Example 2:

Jasmeet works in the same company and earns the same as Suhani. She is very fond of shopping and spends most of her money on buying new clothes. At the end of the month, she is always asking her father for money as her pay is finished.

Ask

- Who do you identify with –Suhani or Jasmeet ?
- How do you think Suhani manages to save money which Jasmeet is unable to do?

Say

- We should always set aside some and save some money from our monthly pay. The future is unpredictable. Saving money not only gives you a sense of financial security but it can be used in case of emergencies.
- Discuss “Importance of Saving” with the participants as given in the Participant Handbook.

Ask

- What are the benefits of saving money?
- What does being financially independent mean to you?

Say

- Discuss “Benefits of Saving” with the participants as given in the Participant Handbook.
- Now let us continue with Suhani's story. Suhani has told her family not to worry and that she has about 50,000, which she has saved over the months. The family is happy about Suhani's decision of saving money, which will be of great help for them now.

Suhani is going to the hospital today to pay the first instalment for the treatment. Suddenly finds only 35,000 in her cash box when she counts and does not remember using it. She has not kept any record and now she is upset.

Ask

- Was it a good decision by Suhani to save a part of her earnings every month?
- Was it a wise decision to keep all her savings as cash in a cash box?
- Could she have managed to save money in a better and more effective manner?
- Do you want to learn how to save money and use it effectively?

Say

- Let's learn personal saving with the help of a group activity.

Team Activity

Personal Finance- Why to save

- This activity has two parts:

PART 1

WAYS TO SAVE MONEY

- You are earning 30,000/- per month. You have recently changed your job and have to move to a metropolitan city. You are now living as a paying guest paying 10,000/- per month. Your other estimated expenditures like travel, food, recreation would be around Rs. 17, 000 per month.
- Make a list of different ways to save money.

PART 2

HOW WILL YOU USE THE MONEY

- After a year how much have you been able to save?
- How will you use the money that you have saved?

Do

- Divide the class into groups of four.
- Instruct the participants to think and prepare a list of the various ways they can save money.
- Give the participants 10 minutes to prepare the list.
- Once done, instruct them to think of how they could use the money they have saved.
- Give the participants 10 minutes to prepare the list.
- Keep a check on time. Tell the group to wind up quickly if they go beyond the given time limit.

Activity De-brief

- What were the different ways you could save money?
- How much money were you able to save?
- How will you use the money you have saved in one year?

Say 

- Discuss the importance of personal finance and why it is important to save money.

Summarize 

You can summarize the session by discussing:

- The importance of saving money.
- Ways to save money.
- How the money saved can be used for different purposes.

UNIT 9.3.2: Types of Bank Accounts, Opening a Bank Account

Unit Objectives

At the end of this unit, participants will be able to:

- Discuss the main types of bank accounts
- Describe the process of opening a bank account

Resources to be Used

- Account opening sample forms
- Participant Handbook

Ask

- How many of you save money?
- Where do you keep the money you save?
- How many of you have a bank account?
- What type of account do you have?

Example

- Let's look at the given example:

Reena is in the third year of college but in the evening she gives tuitions for children living in her colony. She earns 15,000/- per month. As her students stay in different parts of the city, she has to walk a lot.

To save time, she decides to buy a second hand scooter for herself. But she has to save money for it. Her class mate advises her to open a recurring deposit account in the bank.

She goes to the bank close to her home. The personal manager gives her some forms to fill. She is confused as she has never done this before. Her elder sister has an account in the same bank. She asks for help from her sister. She goes to the bank the next day with her sister. The personal banker gives her a list of documents that she will need to submit with the form for opening an account. The banker advises her to open a 6 months recurring deposit.

Ask

- Do you try to save money monthly but have to spend it on unforeseen expenditure?
- Have you ever thought of depositing your savings in a bank?

Say

- Before opening a bank account, you need to know the types of accounts we have in India.
- Discuss "Types of Bank Accounts" with the participants as given in the Participant Handbook.

Ask

- Can someone say what are the different types of bank accounts?

Say 

- Let's learn about the different types of bank accounts through an activity.

Team Activity 

- Divide the class in four groups.
- Label the groups as savings account, current account, recurring account and fixed deposit.
- On a chart paper, ask them to write the key points of their account.

Activity De-brief

- Ask each group to present the key points of their account.

Say 

- Now that you know about the four different types of accounts, let's learn how to open a bank account.
- Discuss "Opening a Bank Account" with the participants as given in the Participant Handbook.
- Discuss "Tips" that the participants should keep in mind while opening a bank account as given in the Participant Handbook.

Ask 

- What are the main documents required for opening a bank account?
- What are some important points to ask the bank personnel while opening an account?

Say 

- Mention officially valid KYC documents (refer to the Participant Handbook)
- Now, let's understand the procedure of opening a bank account through an activity.

Team Activity **Opening a Bank Account**

- This activity is done in groups.
- Divide the class in groups of four or six.

PART 1**FILLING A BANK ACCOUNT OPENING FORM**

- You have to fill a bank opening form.
- You can refer to the section "Opening a Bank Account" of your Handbook for reference.
- List all the steps that you will be required to fill in the form.
- List the documents that you needs for filling the form.
- Now fill in the form.

Activity De-brief**How did you design the form?**

- What all details did you fill in the form?
- What were your KYC documents?
- How would this activity help you in future?

Do 

- Instruct the participants to read the section "Opening a Bank Account" of the Participant Handbook.
- Give each group one sample account opening form.
- Give the participants 5 minutes to read the form.
- Give them 15 minutes to fill it.
- Assist them by explaining each category and how to fill it.
- Keep a check on time.
- Tell the group to wind up quickly if they go beyond the given time limit.

Summarize **Note:**

- You can summarize the unit through a role play.
 - ♦ A person wanting to open an account in the bank.
 - ♦ What is the procedure that he will go through?
 - ♦ Discuss the key points of different types of bank accounts.
 - ♦ How to select the type of account
 - ♦ How to fill the account opening form.
- A sample account opening form is given in the following page for reference. Use it for the activity in the class.

Sample Bank Account Opening form.

Photograph	XXX Bank																																																												
SAVING BANK ACCOUNT OPENING FORM																																																													
Account No.: _____	Date: _____																																																												
<table border="1" style="width: 100%; border-collapse: collapse;"> <tr><td colspan="2">Name of the Branch</td></tr> <tr><td colspan="2">Village/Town</td></tr> <tr><td colspan="2">Sub District / Block Name</td></tr> <tr><td colspan="2">District</td></tr> <tr><td colspan="2">State</td></tr> <tr><td colspan="2">SSA Code / Ward No.</td></tr> <tr> <td>Village Code / Town Code</td> <td>Name of Village / Town</td> </tr> </table>		Name of the Branch		Village/Town		Sub District / Block Name		District		State		SSA Code / Ward No.		Village Code / Town Code	Name of Village / Town																																														
Name of the Branch																																																													
Village/Town																																																													
Sub District / Block Name																																																													
District																																																													
State																																																													
SSA Code / Ward No.																																																													
Village Code / Town Code	Name of Village / Town																																																												
Applicant Details:																																																													
<table border="1" style="width: 100%; border-collapse: collapse;"> <tr> <td style="width: 15%;">Full Name</td> <td style="width: 15%;">Mr./Mrs./Ms.</td> <td style="width: 30%;">First</td> <td style="width: 30%;">Middle</td> <td style="width: 10%;">Last Name</td> </tr> <tr><td colspan="5">Marital Status</td></tr> <tr><td colspan="5">Name of Spouse/Father</td></tr> <tr><td colspan="5">Name of Mother</td></tr> <tr><td colspan="5">Address</td></tr> <tr><td colspan="5">Pin Code</td></tr> <tr> <td colspan="3">Tel No. Mobile</td> <td colspan="2">Date of Birth</td> </tr> <tr> <td colspan="3">Aadhaar No.</td> <td colspan="2">Pan No.</td> </tr> <tr><td colspan="5">MNREGA Job Card No.</td></tr> <tr><td colspan="5">Occupation/Profession</td></tr> <tr><td colspan="5">Annual Income</td></tr> <tr><td colspan="5">No. of Dependents</td></tr> </table>		Full Name	Mr./Mrs./Ms.	First	Middle	Last Name	Marital Status					Name of Spouse/Father					Name of Mother					Address					Pin Code					Tel No. Mobile			Date of Birth		Aadhaar No.			Pan No.		MNREGA Job Card No.					Occupation/Profession					Annual Income					No. of Dependents				
Full Name	Mr./Mrs./Ms.	First	Middle	Last Name																																																									
Marital Status																																																													
Name of Spouse/Father																																																													
Name of Mother																																																													
Address																																																													
Pin Code																																																													
Tel No. Mobile			Date of Birth																																																										
Aadhaar No.			Pan No.																																																										
MNREGA Job Card No.																																																													
Occupation/Profession																																																													
Annual Income																																																													
No. of Dependents																																																													

Detail of Assets	Owning House : Y/N	Owning Farm :
	Y/N	
	No. of Animals :	Any other :
Existing Bank A/c. of family members / household	Y / N	If yes, No. of A/cs. _____
Kisan Credit Card	Whether Eligible Y / N	

I request you to issue me a **Rupay Card**.

I also understand that I am eligible for an Overdraft after satisfactory operation of my account after 6 months of opening my account for meeting my emergency/ family needs subject to the condition that only one member from the household will be eligible for overdraft facility. I shall abide by the terms and conditions stipulated by the Bank in this regard.

Declaration:

I hereby apply for opening of a Bank Account. I declare that the information provided by me in this application form is true and correct. The terms and conditions applicable have been read over and explained to me and have understood the same. I shall abide by all the terms and conditions as may be in force from time to time. I declare that I have not availed any Overdraft or Credit facility from any other bank.

Place:

Date:

Signature / LTI of Applicant

Nomination:

I want to nominate as under				
Name of Nominee	Relationship	Age	Date of Birth in case of minor	Person authorised in case to receive the amount of deposit on behalf of the nominee in the event of my /minor(s) death.

Place:

Date:

Signature / LTI of Applicant

Witness(es)*

1. _____

2. _____

*Witness is requires only for thumb impression and not for signature

UNIT 9.3.3: Costs: Fixed vs. Variables: What are Fixed and Variable Costs?

Unit Objectives

At the end of this unit, participants will be able to:

- Differentiate between fixed and variable costs

Resources to be Used

- Participant Handbook
- Blank sheets of paper
- Pens

Ask

- What is cost?
- Will a telephone bill fall under the category of a fixed or variable cost?

Say

- Discuss: Fixed and Variable cost with examples. Let us do a small activity.

Team Activity

Identify the type of cost

1. Rent
2. Telephone bill
3. Electricity bill
4. Machinery
5. Insurance
6. Office supplies/ Raw materials
7. Employee salaries
8. Commission percentage given to sales person for every unit sold
9. Credit card fees
10. Vendor bills

Do

- Divide the class into two groups. Read out the list of costs given in the activity.
- Read out each item from the cost list and ask the groups in turns to identify whether it is a fixed or variable cost.

Say

- We saw that your utility bills like rent, electricity, telephone etc. are all fixed costs because you have to pay it every month.
- Variable costs is an expense which varies with production output or volume. For example commission, raw material etc.
- Discuss “Cost: Fixed vs. variables” with the participants as given in the Participant Handbook.
- Illustrate the relation between the costs with a graph.

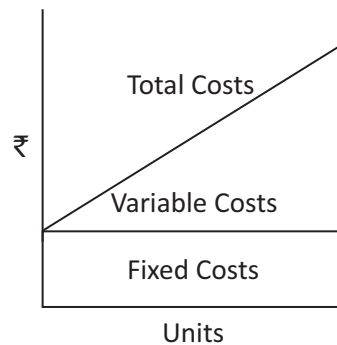

- Let's learn the difference between fixed and variable cost with the help of an activity.

Team Activity

Fixed vs. Variable Costs

- This is a group activity.

- You want to start your own entrepreneur business.
- State the type of business you want to start.
- List down all the cost or requirements for your business.
- How will you differentiate between the fixed and variable cost.

Activity De-brief

- What is the total cost of your business?
- What are the fixed costs?
- What are the variable costs?
- How did you differentiate between the fixed and variable costs?

Do

- Instruct the participants that this is group work.
- Divide the class into small groups of 4 or 6.
- Give each group a sheet of paper.
- Tell the participants that they have to start their own entrepreneur business.
- Ask them the type of business they want to start.
- Instruct them to differentiate between the fixed and the variable costs of the business they want to start.
- Give the participants 15 minutes to discuss and write.
- Keep a check on time. Tell the group to wind up quickly if they go beyond the given time limit.

Summarize

- Note: You can summarize the unit either by having a role play between a consultant and a budding entrepreneur explaining the differences between fixed and variable costs or by discussing the key points of the unit.

Notes for Facilitation

- Answers for the activity - Identify the type of cost
- | | |
|--|------------|
| 1. Rent | (Fixed) |
| 2. Telephone bill | (Fixed) |
| 3. Electricity bill | (Fixed) |
| 4. Machinery | (Fixed) |
| 5. Insurance | (Fixed) |
| 6. Office supplies/ Raw materials | (Variable) |
| 7. Employee salaries | (Fixed) |
| 8. Commission percentage given to sales person for every unit sold | (Variable) |
| 9. Credit card fees | (Variable) |
| 10. Vendor bills | (Variable) |

UNIT 9.3.4: Investments, Insurance and Taxes

Unit Objectives

At the end of this unit, participants will be able to:

- Describe the main types of investment options
- Describe the different types of insurance products
- Describe the different types of taxes

Resources to be Used

- Participant Handbook

Ask

- Ask the participants- “What do you see first thing in when you get your mobile bill? Apart from the amount and due date do you have a look at the taxes you are being billed for?”
- Why do you think people get their cars insured or have a medical insurance?
- You have saved money and want to invest it, how would you decide what is the best investment for your money?

Example

- Let's have a look at a few scenarios.

Ranbir has sold his house and deposited the money in his bank. His Chartered Accountant tells him that he will have to re-invest the money otherwise he will have to pay capital tax. What is capital tax and how is it different from income tax?

Jasmeet and Anup are blessed with a baby girl. They decide to have an insurance policy that will mature when their daughter is ready to higher education.

Shivani is working in a corporate office and getting good pay. She will have to pay income tax so she decides to invest her money in tax saving schemes. She goes to the bank manager to discuss the best products in which she can invest.

Say

- Discuss the Investment, Insurance and Taxes as given in the Participant Handbook.

Ask

- How do investments, insurances and taxes differ from each other?

Say

- Let's learn the differences between the three by having an activity.

Say

- We will have a quiz today.

Team Activity

- The activity is a quiz.

Do

- Divide the class into groups of three and give a name to each group
- Explain the rules of the quiz. For each correct answer the group gets 1 mark. If the group is unable to answer the question is rolled over to the next group.
- Explain the purpose and duration of the activity.
- On the blackboard write the names of the groups.
- Ask the questions of the quiz.
- Keep a score for the groups.
- Set guidelines pertaining to discipline and expected tasks.

Summarize

- Summarize the unit by discussing the key points and answering question

Notes for Facilitation

Questions for the quiz

1. What are bonds?
Bonds are instruments used by public and private companies to raise large sums of money.
2. Who issues the bonds?
Private and public companies issue the bonds.
3. Why are bonds issued?
To raise large amount of money as it cannot be borrowed from the bank.
4. Who is the buyer of stocks and equities?
The general public is the buyer.
5. What types of scheme is the Sukanya Samridhi Scheme?
Small Saving Scheme
6. What is the difference between mutual and hedge funds?
Mutual funds are professionally managed financial instruments that invest the money in different securities on behalf of investors. Hedge funds invest in both financial derivatives and/or publicly traded securities.
7. Why is a loan taken from the bank to purchase real estate?
To lease or sell to make profit on appreciated property price.
8. Name the two types of insurances?
Life Insurance and Non-life or general insurance
9. Which insurance product offers financial protection for 15-20 years?
Term Insurance
10. What is the benefit of taking an endowment policy?
It offers the dual benefit of investment and insurance.
11. Mr. Das gets monthly return on one of his insurance policies. Name the policy?
Money Back Life Insurance

12. What are the two benefits of a Whole Life Insurance?

It offers the dual benefit of investment and insurance

13. Which policy covers loss or damage of goods during transit?

Marine Insurance

14. After what duration is the income tax levied?

One financial year

15. What is long term capital gain tax?

It is the tax payable for investments held for more than 36 months.

16. Name the tax that is added while buying shares?

Securities Transaction Tax

17. What is the source of corporate tax?

The revenue earned by a company.

18. Name the tax whose amount is decided by the state?

VAT or Value Added Tax

19. You have bought a T.V. What tax will you pay?

Sales Tax

20. What is the difference between custom duty and OCTROI?

Custom duty is the charges payable when importing or purchasing goods from another country. OCTROI is levied on goods that cross borders within India.

UNIT 9.3.5: Online Banking, NEFT, RTGS, etc.

Unit Objectives

At the end of this unit, participants will be able to:

- Discuss the uses of online banking
- Discuss the main types of electronic funds transfer

Resources to be Used

- Participant Handbook
- Computer System with internet connection
- Debit card

Ask

- When was the last time you visited a bank?
- How do you pay your bill for electricity and telephone?
- Have you ever tried to transfer money from one bank account to another bank account using the online banking facility?

Say

- Most of us lead a busy life. Time has become more important than money. In this busy schedule no one has time to stand in bank queues. That's where Online Banking comes in. Online banking or internet banking means accessing your bank account and carrying out financial transactions through the internet.
- Discuss "What is online banking?" from the Participant Handbook.
- There are various advantages of online banking:
 - ♦ It saves time, as you need to visit the branch. .
 - ♦ You can conduct your banking transactions safely and securely without leaving the comfort of your home.
 - ♦ Online Banking also gives you round the clock access.
 - ♦ Online Banking makes it possible for you to pay your bills electronically.

Do

- Show them how they can use the internet banking.
- Use the computer system and show the demo videos on how to use internet banking provided on most banking sites. the computer system.
- Tell the class the various features of online banking:
 - ♦ Through their website set-up your online account.
 - ♦ Choose a secure username and password.
 - ♦ Set-up your contact information.
 - ♦ Once your information is verified, you are good to go.
 - ♦ Once you enter the portal explore all the features and learn your way through the portal.
- Discuss about maintaining the security of the online account.

Say



- One of the biggest advantage that online banking offers, as discussed earlier, is transferring money from one account to another. This transaction is called electronic funds transfer. Electronic transfers are processed immediately with the transferred amount being deducted from one account and credited to the other in real time, thus saving time and effort involved in physically transferring a sum of money.
- Discuss “Electronic Funds Transfer” from the Participant Handbook.

Do



- Discuss how to transfer money from one account to another using online banking (NEFT/ RTGS, etc.).
- Illustrate with an example.

Summarize



- Close the discussion by summarizing the about online banking.
- Ask the participants if they have any questions related to what they have talked about so far.

UNIT 9.4: Preparing for Employment & Self Employment

Key Learning Outcomes

At the end of this unit, participants will be able to:

1. Discuss the steps to follow to prepare for an interview
2. Discuss the steps to create an effective Resume
3. Discuss the most frequently asked interview questions
4. Discuss how to answer the most frequently asked interview questions
5. Identify basic workplace terminology

UNIT 9.4.1: Interview Preparation: How to Prepare for an Interview?

Unit Objectives

At the end of this unit, participants will be able to:

- Discuss the steps to follow to prepare for an interview

Resources to be Used

- Participant Handbook

Ask

- Have you ever attended an interview?
- How did you prepare before going for an interview?

Say

- An interview is a conversation between two or more people (the interviewer(s) and interviewee) where questions are asked by the interviewer to obtain information from the interviewee.
- It provides the employer with an opportunity to gather sufficient information about a candidate and help them select the ideal candidate.
- It also provides the interviewee with an opportunity to present their true potential to the employer, build confidence and help make a decision about the job by asking questions regarding designation, salary, perks, benefits, promotions, transfers, etc.
- Let's do an activity to understand how to prepare for interviews better.

Activity 1

- Introducing Yourself

Do

- Select a participant and ask him/her to answer the following questions: "What can you tell me about yourself?"
- Give the participant at least one minute to speak.
- Once he/she is done, ask the rest of the participant what they gathered about the participant who was providing information.
- Now repeat the exercise with five other participants.

Ask

- What information you should include when you are describing or introducing yourself in an interview?
- What information you should not include when you are describing or introducing yourself in an interview?

Say

- Tell the participants that when an interviewer asks you to say something about yourself, he/she is not asking you to present your life history.
- Introduction should be short and crisp, and should present you in a positive light. It should include the following points:
 - ♦ Any work experience that you might have
 - ♦ A brief summary of your educational qualifications
 - ♦ Your strengths and achievements
 - ♦ Any special projects that you might have been part of
- The following topics should be avoided during an introduction:
 - ♦ Detailed description of your family (unless you are specifically asked to do so)
 - ♦ Too much information about your weaknesses
 - ♦ Information that is not true

Do

- Congratulate each participant for sharing their points.
- Ask the audience to applaud for them.
- Ask de-brief questions to cull out the information from each group.
- Keep a check on time.

Activity 2

- Planning the right attire

Do

- Describe 2 individuals to the participants. One is wearing a casual t-shirt, jeans, and slippers. He has not combed his hair and neither has he trimmed or shaved his beard. The other individual is dressed formally with a shirt and pant, and is well-groomed. He has also worn formal shoes and a belt. Ask the participants which person would they prefer to hire in their organization and why?

Summarize

- Close the discussion by discussing 'how to prepare for an interview' as discussed in the Participant Handbook.
- You can add the following points to it:
 - ♦ Tell the participants to create a positive and good impression in an interview. It is important for them to prepare for an interview beforehand.
 - ♦ The interviewer analyses not only your technical knowledge in relation to the job, but also whether or not you are a fit for the organization.
 - ♦ Every employer looks at the whole package and not just one or two things in isolation. Therefore, the way you dress and the way you present yourself is also important along with your skills and talents.
 - ♦ The participants will get only one chance to create a good first impression.

UNIT 9.4.2: Preparing an Effective Resume: How to Create an Effective Resume?

Unit Objectives

At the end of this unit, participants will be able to:

- Discuss the steps to create an effective Resume

Resources to be Used

- Participant Handbook
- Blank papers
- Pens

Ask

- When preparing for an interview, what are the most important things that you need to do?
- What documents do you carry with you, when you go for an interview?
- What is a resume?
- Why do you need a resume?

Say

- Resume is not just a sheet of paper with your qualifications printed on it.
- It is a selling tool that will help the employer to see how and what you can contribute for company.
- Talk about the steps involved in creating an effective/attractive resumes discussed in the Participant Handbook.
- Now let's prepare a resume to understand the process in a better way.

Do

- This is an individual activity.
- Give the details of the activity.
- Instruct them to read the activity carefully.
- The participant is expected to make an attractive resume based on the information provided.
- Give the class 25-30 minutes to study the case and create a resume.
- At the end of 30 minutes, the participants should exchange the resume with the person sitting next to him or her.
- Every participant will evaluate the resume prepared with their fellow participants.

Say

- Do you think the candidate should apply for the job posting described in the advertisement?
- We have already discussed the steps involved in creating an effective/attractive resumes.
- Now let's prepare a resume for the candidate details given in the activity.

Activity

Case Study Analysis

- In the first section of the activity, you are being given the information about a candidate who is applying for a particular job.
- In the second section, you are being given the detailed description of the job posting. Create a resume for the candidate to apply for the job posting.
- Use the information that has been provided about the candidate to create this resume.

Candidate Details

Nipesh Singla was born on 20th April, 1988 in Chandigarh, India. He currently resides at 1XX7, Sector XX D, Chandigarh –160018. His mobile number is 988XXXXX01, and e-mail address is nxxxxxxxla@gmail.com. Nipesh attended middle and senior school at Government Boys Senior Secondary School, Sector 15, Chandigarh. He has been a very talented boy since school. He was fond of painting and watching old Hindi movies. As part of a school charity program, he volunteered at the children's hospital during his senior years.

In July 2007, he joined Westwood School of Hotel Management, Zirakpur to pursue a diploma course in Hotel Management and Catering. After completing this course, he joined XYZ Group of Hotels as a Housekeeping intern in June 2010 for six months. In this role, he was responsible for cleanliness and maintenance of one floor in the hotel. Taking advantage of his strong interpersonal skills, he also got opportunities to make housekeeping arrangements for corporate meetings. While pursuing education, he gained working knowledge of Microsoft Word, Excel, Access and PowerPoint.

Nipesh is detail-oriented, flexible and adaptable. He has successfully worked with a diverse work force. He gelled well with his peers, both in college and during his internship. After completing the internship, his objective has been to find a job opportunity where he can use his skills and experience. Backed by experience, he is confident about his skills as housekeeping assistant.

Job Posting

* Do you see yourself as a HOUSEKEEPING SUPERVISOR?

What's your passion? Whether you're into cricket, reading or hiking, at IHG we are interested in YOU. At IHG, we employ people who apply the same amount of care and passion to their jobs as they do in their hobbies - people who put our guests at the heart of everything they do. And we're looking for more people like this to join our friendly and professional team.

THE LOCATION:

At the moment, we are looking for HOUSEKEEPING SUPERVISOR to join our youthful and dynamic team at Holiday Inn Amritsar, Ranjit Avenue in Amritsar, Punjab (India). Holiday Inn Amritsar is ideally located in Amritsar's commercial district on Ranjit Avenue with the world famous Golden Temple located only a short distance away. Sparkling chandeliers mark an incomparable arrival experience as you escape to the welcoming environment that is, Holiday Inn Amritsar. The fresh international brand to celebrate and explore Amritsar.

Salary: Negotiable

Industry: Travel / Hotels / Restaurants / Airlines / Railways

Functional Area: Hotels, Restaurants

Role Category: Housekeeping

Role: Housekeeping Executive/Assistant.

Desired Candidate Profile

Friendly, pleasant personality, Service - oriented.

You should ideally be Graduate/ Diploma holder in HM and at least 2 years of experience as a supervisor in good brand with good communication skills, English is a must.

In return we'll give you a competitive financial and benefits package. Hotel discounts worldwide are available as well as access to wide variety of discount schemes and the chance to work with a great team of people. Most importantly, we'll give you the room to be yourself.

*Please get in touch and tell us how you could bring your individual skills to IHG.

Education-

UG: Any Graduate/ Diploma holder

PG: Post Graduation Not Required

Say

- Now, let's share the resume with the fellow participant sitting next to you and evaluate each other's effort.

Do

- Congratulate each participant for making their first attempt towards creating an effective resume.
- As a follow up activity, you can suggest them to prepare their own resume and show it to you the next day.

Summarize

- Close the discussion by showing some effective resume samples to the candidates.
- Ask the participants what they have learnt from this activity.
- Ask if they have any questions related to what they have talked about so far.

Notes for Facilitation

- Keep printed copies of the activity ready for the session.
- Put down the suggested format of the resume on the board while explaining the steps in preparing a resume.
- Do check the participants' resume and suggest necessary changes.
- Suggested example for the case presented:

Nipesh Singla

#1XX7, Sector XX-D

Chandigarh-160018

Mobile No: 91-988XXXXX01

E-mail: nxxxxxxxxla@gmail.com

Objective: Seeking an opportunity to use my interpersonal skills and experience to contribute to your company's growth, profitability and objectives.

Professional strengths:

- Proficient in housekeeping
- Experienced in and capable of working with a diverse work force
- Team player and friendly in nature
- Successful working in a multi-cultural environment

- Detail oriented, flexible, and adaptable
- Knowledge of Microsoft Word, Excel, Access and PowerPoint

Educational background:

- Diploma in Hotel Management and Catering, Westwood School of Hotel Management, Zirakpur
- High School, Government Boys Senior Secondary School, Sector 15, Chandigarh

Professional internships:

- Housekeeping Intern, XYZ Group of Hotels, New Delhi (June 2010 – August 2010)
 - ♦ Responsible for cleanliness and maintenance of one floor in the hotel.
 - ♦ Got opportunities to make housekeeping arrangements for corporate meetings.

Volunteer Work:

- Student volunteer at children's hospital in Chandigarh.

Nipesh Singla

UNIT 9.4.3: Interview FAQs

Unit Objectives

At the end of this unit, participants will be able to:

- Discuss the most frequently asked interview questions
- Discuss how to answer the most frequently asked interview questions

Resources to be Used

- Participant Handbook

Say

- Tell the participants you will provide them with interview situation and questions and they have to try to answer them.
- Tell them you will also explain the different ways to approach these questions.

Do

- Divide the class in pairs and ask the participants to perform a role play.
- One partner will play the role of the interviewer while the other will play the role of the interviewee.
- Tell them the interviewer can start the interview by asking the interviewee to introduce himself/herself.
- Call all the pairs one by one in front of the class to enact the role play.
- Follow the same pattern for all other situations.
- Time allotted for each situation is 8-10 minutes.
- Congratulate each participant for giving their input.
- Ask the class to applaud each time a team has completed their role play.
- Keep a check on time.

Role Play

Conduct a role play for the situation given.

Situation 1

- The interviewer will start by asking the interviewee a few generic questions such as:
 - ♦ What is your name?
 - ♦ Tell me something about yourself?
 - ♦ Can you tell me something about your family?
- Then, the interviewer will bluntly ask the following questions:
 - ♦ How do you explain this huge time gap in your resume?
 - ♦ What is the reason for this?
 - ♦ Weren't you looking for a job or is it that no one selected you?

Say

De-brief:

- When you put information on your resume, you should be prepared to answer any questions about it.
- Be present and focused on the questions being asked to you.
- One way of tackling the blunt questions is to tell the interviewer you did not come across an opportunity where you were sufficiently satisfied with both the remuneration offered as well as the profile. Therefore, you waited for the right opportunity to come along while looking for an ideal job.

Role Play

Conduct a role play for the situation given.

Role Play – Situation 2

- The interviewer will start by asking the interviewee a few generic questions such as:
 - ♦ What is your name?
 - ♦ Tell me something about yourself?
 - ♦ Can you tell me something about your family?
- Then, at the end of the interview, ask the interviewee:
 - ♦ There are over 200 people who have applied for this job, some with excellent work experience. Why should I hire you?

Say

De-brief:

- There is nothing wrong with stating your strengths and achievements. However, do not come across as arrogant or too boastful.
- You need show the interviewee that you have unique skills or talents to contribute to the company. The interviewer needs to know how you stand apart from the rest of the crowd.
- Tell the interviewer you are looking forward to working with the company and that you are a hard-working individual.

Role Play

Conduct a role play for the situation given.

Role Play – Situation 3

- The interviewer will start by asking the interviewee a few generic questions such as:
 - ♦ What is your name?
 - ♦ Tell me something about yourself?
 - ♦ Can you tell me something about your family?
- Then, lean forward, clasp your hands on the table and in a soft voice ask the interviewee:
 - ♦ Did you ever experience any neglect or disregard from your previous office? In other words, did you ever suffer because your office or team displayed favouritism?

Say

De-brief:

- Keep this in mind: Do not criticize anyone during an interview.
- You are free to express your opinion, however, your language, answers, body language, and the tone of your voice should remain constructive and neutral.
- Since criticism will show you in negative light, you should keep your answers honest yet diplomatic.
- You can tackle such questions by saying, “I got along well with most of my faculty and peers.”

Role Play

Conduct a role play for the situation given.

Role Play – Situation 4

- The interviewer will start by asking the interviewee a few generic questions such as:
 - ♦ What is your name?
 - ♦ Tell me something about yourself?
 - ♦ Can you tell me something about your family?
- Then very bluntly ask the interviewee:
 - ♦ How long do you plan to stay with this company if you are selected?
- After the candidate responds, ask sarcastically:
 - ♦ Do you seriously mean that?

Say

De-brief:

- Don't provide unreal and idealistic answers.
- Your answers should be honest yet diplomatic. In a situation like this, the interviewer does not expect you to provide a specific timeline.
- You can say something like, “I would like to stay with the company as long as I can contribute constructively and develop as an employee, within the organization, professionally and financially.”

Role Play

Conduct a role play for the situation given.

Role Play – Situation 5

- The interviewer will start by asking the interviewee a few generic questions such as:
 - ♦ What is your name?
 - ♦ Tell me something about yourself?
 - ♦ Can you tell me something about your family?
- Ask him/her how important he/she thinks it is to be punctual in the corporate world.
- After he/she answers, look up sternly at the interviewee and in a crisp voice, say:
 - ♦ You were late for this interview by 10 minutes. That surely does not seem to be in line with what you just said?

Say

De-brief:

- Politely apologize for being late.
- You can add something such as, “I assure you this is not a habit”. All your future actions should be in line with this statement.
- Avoid giving any excuses.
- You might feel obligated to provide a justification for your tardiness, but the interviewer is not interested in that.
- Do not over apologize. Once this response is out of the way, turn your focus back to the interview.

Role Play

Conduct a role play for the situation given.

Role Play – Situation 6

- The interviewer will start by asking the interviewee a few generic questions such as:
 - ♦ What is your name?
 - ♦ Tell me something about yourself?
 - ♦ Can you tell me something about your family?
- After asking a few academic or job-related questions, ask the interviewee:
 - ♦ If you get this job, what salary package do you expect us to give you?

Say

De-brief:

- If there is no way for you to avoid this question, respond to the interviewer by providing a reasonable and well-thought out salary range.

Role Play

Conduct a role play for the situation given.

Role Play – Situation 7

- The interviewer will start by asking the interviewee a few generic questions such as:
 - ♦ What is your name?
 - ♦ Tell me something about yourself?
 - ♦ Can you tell me something about your family?
- Then, bringing the interview to a close, ask the interviewee:
 - ♦ Do you have any questions for me?

Say

De-brief:

- Ask relevant questions.
- Don't bombard the interviewer with questions.
- If you have questions about the result of the interview, you can limit your questions to 1 or 2. Keep them short and relevant like:
 - ♦ When will I be informed about the results of the interview?
 - ♦ What are the working hours?
 - ♦ Will the job require me to travel?

Explain

- Tell the participants to be prepared for answering different types of questions in an interview.
- Stay calm and focused, and take a moment to think about how you should respond. Always maintain a confident tone.
- Even if you don't intend to, your body language conveys your level of discomfort with a particular question. Try to keep your actions, tone, and gestures neutral.
- Maintain your composure while answering personal question.

Do

- Tell all the participants to form pairs again.
- Tell them to use the following list of frequently asked interview questions to conduct mock interviews.
- They will use all or some of these questions to conduct mock interviews with their partners.
- One partner will play the role of the interviewer while the other will play the role of the interviewee.
- After they are through asking and answering the questions, the roles will be reversed.
- The same list of questions will be used again.
- After each mock interview ask the interviewer to provide feedback and clear any doubts that may arise.
- Time allotted for each situation is 30-35 minutes.

Activity

Mock Interview Questions

Mock Interview Questions
Tell me something about your family.
What qualities would you look for in a Manager or a Supervisor?
Why did you apply for this job?
What do you know about this company?
How do you deal with criticism?
How do you plan to strike a good work-life balance?
Where do you see yourself five years from now?
Have you applied for jobs in other companies?
What kind of salary do you expect from this job?
Do you have any questions for me?

Summarize

- Close the discussion by discussing the questions in the both activities.
- Ask the participants what they have learned from this activity.
- Ask if they have any questions related to what they have talked about so far.

UNIT 9.4.4: Work Readiness – Terms and Terminology

Unit Objectives

At the end of this unit, participants will be able to:

- Identify basic workplace terminology

Resources to be Used

- Participant Handbook
- Chart papers
- Blank sheets of paper
- Pens

Ask

- What do you understand by workplace terminology?
- Are offer letter and contract of employment the same?

Say

- Let's start this unit with an activity.

Team Activity

Workplace terminology

- This is a group activity conducted in three parts.

Part 1

Sheila received a call from the recruiter of MND Company. Before she is recruited by the company, think of the recruitment process she will have to go through. Start from the telephone call to signing her letter of acceptance. Write down all the words that come to your mind.

Activity De-brief

- Have the participants read out the words they have written
- Encourage all the participants to participate in the activity

Do

- Divide the class into small groups of 4 or 6.
- Instruct the participants that they will be doing a brainstorming activity.
- Give them one chart paper each. Tell them to divide the chart in two parts.
- Instruct them that they have to use one half of the chart paper now. The other half will be used later.
- The participants have to write all the words that come to their mind related to the recruitment process.
- Give them 10 minutes to do the activity.
- Tell them that there are no right or wrong answers.
- Keep a track of the time.

Say 

- You all know quite a few words related to the terms used in the office.
- Let us talk about some new terms that have been missed out.
- Discuss “Work Readiness – Terms and Terminology” with the participants as given in the Participant Handbook.

Ask 

- Why is it important to know the workplace terms?
- How do they help?
- Can the words be categorised further?

Say 

- Let's now continue the activity.

Team Activity 

Terms and Terminology

- This is again a group activity. The members of the group remain the same as in Activity 1.

Part 2

With the help of the new terms you have learned, make a flow chart of the hiring process of MND Company.

Activity De-brief

- Ask the groups to share the flow charts and the new terms they added while preparing the flow chart.

Do 

- Instruct the participants that they have to use the 2nd half of the same chart they had used before.
- Using the new terminology and the terms they had previously written on the chart, they have to make a flow chart of the hiring process of the MND Company.
- Give them 10 minutes for this activity.
- Keep a check on time. Tell the group to wind up quickly if they go beyond the given time limit.

Say 

- Let's go ahead with the activity.

Team Activity 

Terms and Terminology

- The activity continues with the same group members.

Part 3

Sheila now works for the MND Company. She is not aware of the company culture and policies. She goes to the HR Department to get her doubts clarified. Can you think of the terms for which she wants clarity? Make a list of those words.

Activity De-brief

- Ask the groups to share their list of words. Some of the words are benefits, comp. time, deduction, employee training, holidays, lay-off, leave, maternity leave, mentor, notice, paternity leave, and time sheet.

Do 

- Instruct the participants to identify the key terms an employee of a company should know. They can use the same chart paper for this activity.
- Give them 5 minutes for this activity.
- Keep a check on time. Tell the group to wind up quickly if they go beyond the given time limit.

Summarize 

- Note: You can either summarize the key points of the unit or have a role play where an employee has just joined a company and the HR Manager explains the terms of employment.

UNIT 9.5: Understanding Entrepreneurship

Key Learning Outcomes



At the end of this unit, participants will be able to:

1. Discuss the concept of entrepreneurship
2. Discuss the importance of entrepreneurship
3. Describe the characteristics of an entrepreneur
4. Describe the different types of enterprises
5. List the qualities of an effective leader
6. Discuss the benefits of effective leadership
7. List the traits of an effective team
8. Discuss the importance of listening effectively
9. Discuss how to listen effectively
10. Discuss the importance of speaking effectively
11. Discuss how to speak effectively
12. Discuss how to solve problems
13. List important problem solving traits
14. Discuss ways to assess problem solving skills
15. Discuss the importance of negotiation
16. Discuss how to negotiate
17. Discuss how to identify new business opportunities
18. Discuss how to identify business opportunities within your business
19. Explain the meaning of entrepreneur
20. Describe the different types of entrepreneurs
21. List the characteristics of entrepreneurs
22. Recall entrepreneur success stories
23. Discuss the entrepreneurial process
24. Describe the entrepreneurship ecosystem
25. Discuss the purpose of the Make in India campaign
26. Discuss key schemes to promote entrepreneurs
27. Discuss the relationship between entrepreneurship and risk appetite
28. Discuss the relationship between entrepreneurship and resilience
29. Describe the characteristics of a resilient entrepreneur
30. Discuss how to deal with failure

UNIT 9.5.1: Concept Introduction (Characteristic of an Entrepreneur, types of firms/ types of enterprises)

Unit Objectives

At the end of this unit, participants will be able to:

- Discuss the concept of entrepreneurship
- Discuss the importance of entrepreneurship
- Discuss the characteristics of an entrepreneur
- Describe the different types of enterprises

Resources to be Used

- Participant Handbook

Say

- Let's start this session with some interesting questions about Indian entrepreneurs.

Team Activity

Quiz Questions

1. Who is the founder of Reliance Industries?
Dhirubhai Ambani
2. Who is the Chairman of Wipro Limited?
Azim Premji
3. Who launched e-commerce website Flipkart?
Sachin Bansal and Binny Bansal
4. Who is the founder of Paytm?
Vijay Shekhar Sharma
5. Who is CEO of OLA Cabs?
Bhavish Aggarwal
6. Who is the founder of Jugnoo?
Samar Singla (autorickshaw aggregator)
7. Who is the founder of OYO Rooms?
Bhavish Aggarwal

Do

- Tell them that you will ask them few questions about a few entrepreneurs.
- Divide the class in to two groups.
- In turns ask the quiz questions to the groups.
- If the answer is incorrect pass the question to the other group.
- Share the answer if the groups are not able to answer.
- Congratulate the participants who answered correctly.

Ask



- What do you understand by entrepreneurs?
- What is the importance of entrepreneurship in today's scenario?
- What do you think are the characteristics of successful entrepreneurs?
- What are different types of enterprises that an entrepreneur in India can own and run?

Say



- Talk about entrepreneurs, importance of entrepreneurship, characteristics of successful entrepreneurs, and different types of enterprises in India as discussed in the Participant Handbook.
- Tell the participants, stories of successful Indian entrepreneurs- their struggles, the moments of heartbreak, the perseverance and triumph.
- Ask them if they know of any such entrepreneur.

Summarize



- Close the discussion by summarizing about the opportunities for entrepreneurs in India.

Notes for Facilitation



- Check out different Government schemes for small entrepreneurs. Share the information with the participants.
- You can tell them about the government websites like Start Up India, mudra.org.in etc.
- Discuss about various schemes and policies by the Government of India for entrepreneurs.

UNIT 9.5.2: Leadership and Teamwork

Unit Objectives

At the end of this unit, participants will be able to:

- List the qualities of an effective leader
- Discuss the benefits of effective leadership
- List the traits of an effective team

Resources to be Used

- Participant Handbook
- Blank sheets of paper
- Pens

Do

- Show the picture given below to the class.
- Ask them to quickly write on a piece of paper what comes to their mind after seeing the picture.
- Now ask them, “What do you understand from this picture?”
- Encourage participants to share their thoughts.

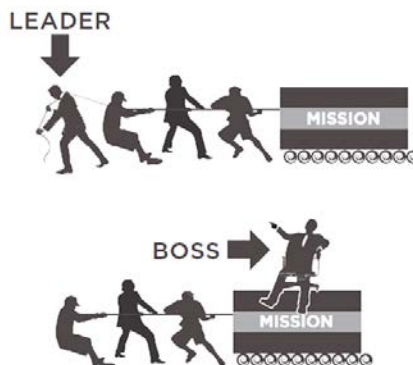

Say

- This picture depicts the qualities of a leader and the difference between a leader and a boss.
- A boss focuses on structure and inspires fear whereas a leader follows vision and generates enthusiasm.
- A boss blames employees for the breakdown whereas a leader fixes breakdowns.
- A boss depends on authority whereas a leader depends on goodwill.
- A boss says “I” and a leader says “We.”
- A boss drives employees whereas a leader coaches them.
- A boss takes credit whereas a leader gives credit.

Say

- Talk about leadership and leadership qualities for an entrepreneur as discussed in the Participant Handbook.

Ask

- Why is it important for a leader to be effective? How does it help the organization?

Say 

- Let us discuss benefits of effective leadership as discussed in the Participant Handbook.
- “Out-of-the-box thinking” is one of the new leadership styles. It means thinking differently and from a new perspective.

Ask 

- Do you consider yourself a team player?

Team Activity **Long Chain**

- This is a group activity.

Do 

- Divide the class into 2 teams.
- Ask each team to create a chain using materials they have in class such as shoe laces, belts, paper, handkerchief, ribbons, etc.
- The team that creates the longest chain wins the game.
- Observe if the participants are interacting with their team or working in isolation.
- Share your observations with the class.

Say **De-brief:**

- What did the winning team do differently?
- Who was responsible for the winning team's success?
- How does this activity explain the role of teamwork in entrepreneurial success?

Say 

- Tell the class that both the teams performed well.
- Discuss that the objective of this activity was to open communication channels and how this has been achieved.
- The participants should aim to keep the communication channels open when interacting with their peers and team members.
- It will set the pace and enthusiasm required for all the ensuing teamwork activities.
- Talk about teamwork and importance of teamwork in entrepreneurial success as discussed in the Participant Handbook.

Summarize 

- Close the discussion by summarizing about the importance of teamwork for employees.
 - ♦ Teamwork helps in reducing stress for the employees.
 - ♦ Teamwork helps employers in generating more number of solutions to a problem and developing improved communication amongst employees.
- Ask the participants what they have learned from these exercises.
- Ask if they have any questions related to what they have talked about so far.

UNIT 9.5.3: Communication Skills: Listening & Speaking: The Importance of Listening Effectively

Unit Objectives

At the end of this unit, participants will be able to:

- Discuss the importance of listening effectively
- Discuss how to listen effectively
- Discuss the importance of speaking effectively
- Discuss how to speak effectively

Resources to be Used

- Participant Handbook

Activity 1

Activity – Chinese Whisper

Step 1: Form a circle.

Step 2: Start a whisper chain. Any one participant will whisper a message into his/her neighbour's ear. No one else must hear the message. The message can be serious or downright silly.

Step 3: The next person who first heard the message should whisper the message very quickly to the person sitting next to them.

Step 4: The game goes on until the last person says whatever they heard out loud and the first person reveals the real message.

Compare them and have a great laugh!

Ask

De-brief questions:

- Was the original message the same as the message that is communicated at the end of the game?
- Why do you think there was a difference in the messages?

Say

- No, the original message was not same at the end of game.
- The barriers to communication like language, disturbance and noise, poor listening skills, boredom, poor speaking skills, etc. are the potential reasons this happens.
- There are various aspects to communication. Speaking skills and listening skills are two major components to any communication. There is always some room for improvement in the way we communicate.
- It is important to accept the reality of miscommunication and work to minimise its negative impacts.

Say 

- Communication is a two-way process where people exchange information or express their thoughts and feelings
- It involves effective speaking and effective listening.
- If I go to the store to get bread, I exchange money for the bread. I give something and get something in return. Communication takes place in the same manner. You have to provide and receive information for communication to take place.

Ask 

- How often do you hear these statements?
 - ♦ “You're not listening to me!”
 - ♦ “Why don't you let me finish what I'm saying?”
 - ♦ “You just don't understand!”
- What do you think the other person is trying to convey to you through these sentences?
- We will not talk about the importance of listening effectively as discussed in the Participant Handbook.

Say 

- Let's play a game to understand effective listening process better.

Do 

- This is a class activity.
- The participants need to answer the questions they hear.
- Instruct them to listen carefully.
- You will read it at a stretch and if need be repeat it once more.
- Tell the participants to raise their hand if they know the answer to the question asked.
- Keep a check on time.

Activity 2 

Riddles:

Is there any law against a man marrying his widow's sister?
If you went to bed at eight o'clock at night and set the clock's alarm to ring at nine o'clock, how many hours of sleep would you get?
Do they have a 26th of January in England?
If you had only one match and entered a dark room that had a kerosene lamp, oil heater, and a wood stove, what would you light first?
The Delhi Daredevils and the Chennai Super Kings play five IPL matches. Each wins three matches. No match was a tie or dispute. How is this possible?
There was an airplane crash. Every single person died, but two people survived. How is this possible?
If an airplane crashes on the border of two countries, would unidentified survivors be buried in the country they were travelling to or the country they were travelling from?
A man builds an ordinary house with four sides except that each side has a southern exposure. A bear comes to the door and rings the doorbell. What is the colour of the bear?

Answers:

There's no law against a man marrying his widow's sister, but it would be the neatest trick in the book since to have a widow, the man would have to be dead.

You'd get one hour's sleep since alarm clocks do not know the difference between morning and night.

Oh, yes. They have a 26th of January in England. They also have a 27th, a 28th, and so on.

First of all, you would light the match.

Who said the Delhi Daredevils and the Chennai Super Kings were playing against each other in those games?

Every SINGLE person died, but those two were married.

You can't bury survivors under any law especially if they still have enough strength to object.

The bear that rang the doorbell would have to be a white bear. The only place you could build a house with four southern exposures is at the North Pole where every direction is in South.

Ask **De-brief question:**

- What were the barriers that came into your way of listening?
- How can you overcome barriers to listening?

Say 

- There is a difference between hearing and listening.
- If you don't listen properly, the message may be misunderstood.
- Be open-minded while listening to someone.
- It is important to listen effectively and carefully without making assumptions.

Activity 3 **Elevator Pitch:**

You are in the lift of a hotel and you bumped into your former client who is a famous businessman. He has financed a lot of small business ventures and can finance your new start-up too. After exchanging pleasantries, he asks you what your new company does. You open your mouth, and then pause. Where do you even begin?

Then, as you try to organize your thoughts, his meeting is called, and he is on his way. If you would have been better prepared, you're sure that he would have stayed long enough to schedule a meeting with you too.

If you were given another chance, what would you have said to this person?

Do 

- Start off the task by providing a beginning sentence to get the story started, and then go around the classroom getting each one to add a new sentence to keep the story going.
- This task should be done spontaneously allowing only a little time to think (30 seconds).
- For example: **There was once a student who was looking for a job after graduation.**

Notes for Facilitation

- Tell the participants to follow these steps to create a great pitch, but bear in mind that you'll need to vary your approach depending on what your pitch is about.
 1. **Identify Your Goal:** Start by thinking about the objective of your pitch. For instance, do you want to tell the potential clients about your organization? Do you have a great new product idea that you want to pitch to an executive or do you want a simple and engaging speech to explain what you do for a living?
 2. **Explain What You Do:** Start your pitch by describing what your organization does. Focus on the problems that you solve and how you help people. Ask yourself this question as you start writing: what do you want your audience to remember most about you? Keep in mind that your pitch should excite you first. After all, if you don't get excited about what you're saying neither will your audience. People may not remember everything that you say, but they will likely remember your enthusiasm.
 3. **Communicate Your USP:** Your elevator pitch also needs to communicate your unique selling proposition or USP. Identify what makes you, your organization or your idea unique. You'll want to communicate your USP after you've talked about what you do.
 4. **Engage with a Question:** After you communicate your USP, you need to engage your audience. To do this, prepare open-ended questions (questions that can't be answered with a "yes" or "no" answer) to involve them in the conversation. Make sure that you're able to answer any questions that he or she may have.
 5. **Put it all Together:** When you've completed each section of your pitch, put it all together. Then, read it aloud and use a stopwatch to time how long it takes. It should be no longer than 20-30 seconds. Remember, the shorter it is, the better!

Example:

Here's how your pitch could come together:

"My company deals with cloth retail online business and we use various e-commerce platforms to sell our products. This means that you can do shopping with ease and spend time on other important tasks. Unlike other similar companies, we have a strong feedback mechanism to find out exactly what people need. This means that, on average, 95 percent of our clients are happy with our products. So, how can you help us in creating our own web portal?"

6. **Practice:** Like anything else, practice makes perfect. Remember, how you say it is just as important as what you say. If you don't practice, it's likely that you'll talk too fast, sound unnatural or forget important elements of your pitch. Set a goal to practice your pitch regularly. The more you practice, the more natural your pitch will become. Practice in front of a mirror or in front of colleagues until the pitch feels natural.

Summarize

- Close the discussion by summarizing how to speak effectively as discussed in the Participant Handbook.

UNIT 9.5.4: Problem Solving & Negotiation Skills

Unit Objectives

At the end of this unit, participants will be able to:

- Discuss how to solve problems
- List the important problem solving traits
- Discuss ways to assess problem solving skills
- Discuss the importance of negotiation
- Discuss how to negotiate

Resources to be Used

- Participant Handbook

Ask

- What is a 'problem'?
- What do you think are the problems you may face in the process of becoming a successful entrepreneur?

Say

- Discuss the definition of problem as given in the Participant Handbook.
- In a hurdle race the hurdles are the obstacles on the way to reach your goal.
- Similarly, obstacles are the hurdles you may face while reaching your goal i.e. to set-up your own business. Your goal will be to reach the finishing line after crossing these hurdles.

Ask

- What do you do when you face a problem?
- How do you resolve it? You can pick examples from the question asked previously 'the problems they are likely to face in the process of becoming a successful entrepreneur'.

Say

- Discuss how to solve problems as given in the Participant Handbook.

Team Activity

- This is a group activity.
 - The groups will solve the problem and come up with the best solution in each case.
1. Unable to arrange for some extra finance for setting up a beauty parlour. The loan sanctioned and disbursed is not enough. You have tried all your contacts, friends and relatives. But unable to manage the extra amount. Bank will not sanction more amount as you have used up the complete sanction limit.
 2. You have rented a space for your business and all arrangements are done. You will be operating from the office space rented in two days. Now the owner comes up to you and says he wants to sell the place and wants you to vacate in 15 days.
 3. You have just set up your business and need extra human resource. You have tried inviting a few also tied up with an agency for getting the right candidate. But you are unable to get the right candidate. If the candidate is good, you cannot offer the salary demanded. If the candidate agrees to the salary, he/she has other demands like working hours to be reduced, leaves etc. which may not work for your set up.

Do 

- Divide the class into three groups. Give one scenario to each group.
- Explain the purpose and duration of the activity.
- Ask the groups to build on the scenario and present their solution as a role play.

Say **De-brief questions:**

1. What was the problem?
2. Is there any other alternative solution?
3. Is this the best solution presented?

Ask 

- Try to think of some people around you who are able to solve problems very easily. Even you or your friends might be approaching them when there is a problem. What qualities do they have? What personality traits do such people possess?

Say 

- Discuss the important traits for problem- solving as given in the Participant Handbook.

Ask 

- In order to build a successful organization, you need to hire people who possess good problem solving skills. How would you assess the level of problem solving skills of potential candidates before hiring them?

Say 

- Discuss how to assess for problem- solving skills as given in the Participant Handbook.

Summarize 

- Ask the participants the things that they have learnt so far.
- Ask if they have any questions related to what they have talked about so far.
- Summarize the discussion on problem solving.

Activity 

- The activity is to organise an election event. Select three volunteers from the group. They have to give a speech on their election manifesto to the class. They have to negotiate with the fellow participants and convince them to vote for them. The best negotiator will win the election.

Do 

- Ask three participants to volunteer for the activity.
- Explain the purpose and duration of the activity.
- Set guidelines pertaining to discipline and expected tasks.

Ask 

- Out of the three contestants, whom would you support? Why? What did they say or do which convinced you to make your decision?
- Have you ever tried to negotiate in your personal or professional life?
- Ask the class to share some of their experiences where they have been able to strike a deal by negotiating.

Say 

- Discuss “What is Negotiation?” as given in the Participant Handbook.

Ask 

- Why is it important to negotiate? As an entrepreneur, where do you think that negotiation skills will be needed?

Say 

- Discuss the importance of negotiation while starting a business as given in the Participant Handbook.

Say 

- Discuss the important steps to negotiate as given in the Participant Handbook.

Role Play 

- Conduct a role play activity.
- Ask the participants to assemble together.
- Explain the purpose and duration of the activity.
- Set guidelines pertaining to discipline and expected tasks.

Do 

- Divide them into groups of four (4) (depending on the batch size).
- Give them the hand-outs for role play scenarios.
- Two groups to be given scenarios on problem solving.
- Other two groups to be given scenarios on negotiation.
- The groups will build on the scenarios and prepare for the role play.
- Give the groups atleast 5 mins to discuss and be ready with the role play.
- Invite each group one by one to come and present their role play.

Problem solving Scenario 1

Avinash has a Mobile Repair Store in Allahabad. His outlet is one of the most popular one in the vicinity and he has great rapport with his customers. He is always well-dressed, jovial and full of energy.

It's around 11 AM, when a customer barges in to the shop and starts shouting at Avinash for giving her back the instrument which is still not working. The screen of her mobile is also cracked from one side. Avinash remembered thoroughly checking the handset before handing it over to the customer. The customer threatens to sue the company and to go to Consumer Court for cheating her.

Problem solving Scenario 2

You are running a successful small scale business, Shreeji Aggarbattis,. Your staff members do door to door selling and organise marketing campaigns in local markets. Your brand has established it's name in last few years.

Recently, lot of customers have been coming to you and lodging complaints that your staff members indulge in malpractices. Few of them informed you that a staff member engaged them in a friendly conversation. In the meanwhile, the other gave them lesser packets of aggarbattis than they paid for.

Another set of customers lodged complaint about the misconduct and rude behaviour of a particular staff member.

You often hear from your customers that the orders don't get delivered on time or wrong products get delivered.

You have already been struggling with shortage of staff and such complaints are a serious concern as it is hampering your brand image. What strategies will you adopt to solve this problem?

Negotiation Scenario 1

You have interviewed a prospective new employee who could be a key member of your new entrepreneurial venture. The new person is demanding a salary that is 20% higher than you thought based on your business plan. Finances are tight, yet you believe this person could make a significant impact on future profits. If you paid the required salary for the new person, then you would have to restructure your entire business plan. You've been searching for an individual with this skill level for three months. to the candidate is waiting for your response. Now you have to call him in to make the final negotiations.

Negotiation Scenario 2

You are a young entrepreneur who has just registered his start up project and applied for a bank loan accordingly. You receive a letter saying that your loan application has been rejected as your start up idea did not appeal to the bank and they think that it is not a revenue generating model. You have taken an appointment to meet the manager and show your negotiation skills to get your loan approved.

Notes for Facilitation

**Facilitating Role Plays****Preparing for the activity**

1. Carefully review the details of the scenario and the character descriptions.
2. Become familiar with the key issues being addressed in the scenario.
3. Study the provided material so that you are ready to address issues related to the situations depicted in the role-plays.
4. Anticipate and know how to address issues participants might raise during the activity.

Conducting the activity

1. Introduce the activity. Emphasize that role-playing provides participants with an opportunity to apply their new knowledge, skills, and tools in situations that simulate actual interactions with customers.
2. Ask participants to form pairs. Direct the members of each group to choose who will play the roles. Remind the groups that each participant should be given the opportunity to play/practice the different roles.
3. Conduct a demonstration so that participants become familiar with the expectations related to the roles and support materials.
4. Give the pairs/ groups 10 to 15 minutes to conduct the role-play (depending on the duration of the session).
5. After all the groups have finished with the role-play, conduct a debriefing session on each role-play.
6. Ask the groups to take five minutes to talk about what happened during the role-play. The groups should discuss the questions given in the debriefing for each role-play. Encourage participants to provide constructive criticism during their discussions.

Summarize



- Wrap the unit up after summarizing the key points and answering questions.

UNIT 9.5.5: Business Opportunity Identification: Entrepreneurs and Opportunities

Unit Objectives

At the end of this unit, participants will be able to:

- Discuss how to identify new business opportunities
- Discuss how to identify business opportunities within their business

Resources to be Used

- Participant Handbook
- Blank sheets of paper
- Pens

Ask

- How does an entrepreneur identify an opportunity?
- What do you think are the common queries or concerns faced by entrepreneurs?
- How can you identify new business opportunity?

Say

- Let's talk about opportunity, common queries or concerns faced by entrepreneurs, idea as an opportunity, factors to consider when looking for opportunities, ways to identify new business, and opportunity analysis as discussed in Participant Handbook.
- Let's do an activity to understand ways to identify business opportunities within your business.

Do

- Tell the class that this is an individual activity.
- Tell the participants to create a matrix on their notebooks.
- There will be four boxes in your matrix.
- Strength, Weakness, Opportunity and Threats will be the four headings of the matrix. This is called the SWOT matrix.
- Read out the questions to them and tell the participants they need to answer the questions asked in each matrix.
- Tell them they can also use their own understanding of themselves to fill the SWOT matrix.

Activity

Do your SWOT analysis

Strength

What are your strengths?
What unique capabilities do you possess?
What do you do better than others?
What do others perceive as your strengths?

Weakness

What are your weaknesses?
What do your competitors do better than you?

Opportunity

What trends may positively impact you?
What opportunities are available to you?

Threat

Do you have solid financial support?
What trends may negatively impact you?

Do



- Congratulate everyone for the class activity.
- Ask the audience to applaud for themselves.
- Allot the participants sufficient time to complete this activity, but do keep a check on time.
- Ask de-brief questions to cull out information from the participants.

Ask



De-brief questions:

- What are your weaknesses according to your SWOT analysis?
- Do you think you can change your weakness into strength? How?
- Do you think you can work on your threats? How?

Summarize



- Close the discussion by summarizing ways to identify business opportunities within your business.
- Ask the participants what they have learned from this exercise.
- Ask if they have any questions related to what they have talked about so far.

UNIT 9.5.6: Entrepreneurship Support Eco-System

Unit Objectives

At the end of this unit, participants will be able to:

- Explain the meaning of entrepreneur
- Describe the different types of entrepreneurs
- List the characteristics of entrepreneurs
- Recall entrepreneur success stories
- Discuss the entrepreneurial process
- Describe the entrepreneurship ecosystem
- Discuss the purpose of the 'Make in India' campaign
- Discuss the key schemes to promote entrepreneurs

Resources to be Used

- Participant Handbook
- Chart papers
- Marker pens
- Pencils
- Colour pencils
- Scale
- Eraser
- Other requisite stationery material

Ask

- Do you think that entrepreneurs need support?
- What do you think is an eco-system?
- What do you think 'entrepreneurship support eco-system' means?

Say

- Let's learn what entrepreneurship support eco-system means.
- Discuss 'Entrepreneurship Support Eco-System' as given in the Participant Handbook.

Ask

- Can you define entrepreneurship support eco-system?
- What are the key domains of the support eco-system?

Say

- Let's learn more about these domains by conducting an activity.
- You have to make a poster showing the components of the six main domains of entrepreneurship support eco-system.

Team Activity

- Making a poster showing the entrepreneurship support eco-system.

Do 

- Divide the class into groups of four or six.
- Hand out chart paper and coloured pens.
- Explain the purpose and duration of the activity.
- Go around checking the progress of each group.
- Set guidelines pertaining to discipline and expected tasks.

Activity De-brief

Ask each group to display their poster and explain the key domains of entrepreneurship support eco-system.

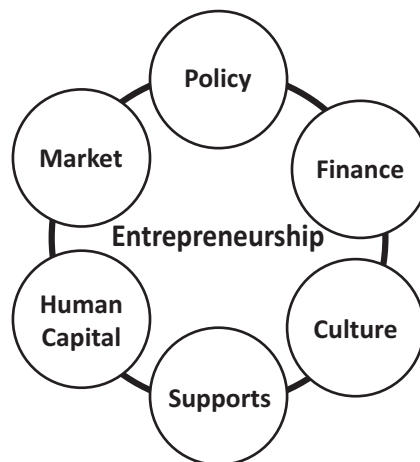
Ask 

- What kind of government support eco-system is available for entrepreneurs in India?

Say 

- Discuss 'Make in India' campaign as given in the Participant Handbook.

Team Activity 

- Presentation on key schemes to promote entrepreneurs

Do 

- Divide the class into pairs.
- Number each pair from 1-15.
- Assign a scheme, same as their group number, to each group.
- Ask them to read the scheme carefully and present it to the class.
- Explain the purpose and duration of the activity.
- Go around checking the progress of each group.
- Set guidelines pertaining to discipline and expected tasks.

Activity De-brief

- Ask each group to explain the scheme offered by government to promote entrepreneurs.

Summarize 

- Summarize the unit by discussing the key points and answering questions the participants may have.

UNIT 9.5.7: Risk Appetite & Resilience

Unit Objectives

At the end of this unit, participants will be able to:

- Discuss the relationship between entrepreneurship and risk appetite
- Discuss the relationship between entrepreneurship and resilience
- Describe the characteristics of a resilient entrepreneur

Resources to be Used

- Participant Handbook
- Chart papers
- Blank sheets of paper
- Pens
- Marker pens

Ask

- Can you define risk or explain what constitutes a risk?
- What do you people mean when they say, “This may be a risky proposition”?
- What risks are they talking about?

Example

- Let's have a look at these two examples:

Rohit and his family were travelling by car from Delhi to Nainital. It was their second trip there. Rohit was familiar with the road. His friends told him that the highway after Rampur was in a bad condition. They advised him to take a shortcut and turn left from Moradabad and take the Kaladhungi road. This road is in a better condition.

Since he was going with his family, and did not want to take the risk of getting lost, he left early. He took the Kaladhungi road and reached Nainital well in time.

Suresh and his family too were travelling by car from Delhi to Nainital. It was their second trip there. His friends too advised him to take a shortcut and turn left from Moradabad and take the Kaladhungi road as this road was in a better condition.

Suresh too decided to take the Kaladhungi road but he left Delhi in the afternoon. It was dark by the time he reached Kaladhungi, and he was sure that he was taking the correct turn. As it was late, he could not find anyone to give him directions. He ended up being in an unknown place that was scarcely inhabited.

Say

- Let's see what type of risks Rohit and Suresh took.
- Discuss 'Risk Appetite and Resilience' with the participants as given in the Participant Handbook.

Say

- Let's learn more about risk appetite and resilience with the help of an activity.

Team Activity

Risk Appetite

- This is a group activity.

- In the previous unit, you read success stories of Mr Dhirubhai Ambani and Dr Karsanbhai Patel.
- Mr Ambani left his job and started his company Reliance with just Rs. 50,000/-.
- Dr Patel kept his job, went door-to-door to sell Nirma, and only when the brand started gaining popularity did he start his own company.
- What types of risk did both of them take?
- What risk factors, do you think, did they keep in mind before launching their company?
- Write the Risk Appetite Statement of both the companies.

Activity De-brief

- Who took a greater risk?
- What are the differences between the Risk Appetite Statement of both the companies?

Do

- Instruct the participants that this is group work.
- Divide the class into small groups of 4.
- Give each group a chart paper.
- Tell the participants that they have to evaluate the risks taken by Mr Dhirubhai Ambani and Dr Karsanbhai Patel.
- Give the participants 15 minutes to discuss and write.
- Keep a check on time. Tell the group to wind up quickly if they go beyond the given time limit.

Ask

- Do you think all entrepreneurial ventures are successful?
- What happens if the first venture is not successful?
- Should the entrepreneur stop when faced with challenges or face them?

Example

- Let's have a look at the following example:

Vijay Shekhar Sharma is the founder of Paytm, which is a giant Indian e-commerce. He was born in a middle-class family in Uttar Pradesh. He started his first job at an MNC. He quit after six months and built a company One97 with his friends. As One97 grew bigger, it needed more money because it was running more servers, bigger teams, and had to pay royalty. At that time, the tech bubble popped and technology companies were running in losses. Finally, money ran out. So One97 took loans and then more loans at higher rates of interest, as high as 24 per cent, and became caught in a vicious cycle.

In 2014, Paytm was launched with online wallet services after which, the company enabled online payment transactions. The company got licenses from RBI in 2016 to launch India's first ever payment bank. Moreover, the main motive of Paytm was to transform India into a cashless economy.

After demonetization came into effect, Vijay Shekhar Sharma started promoting online and digital transactions to deal with the cash crunch. In fact, the service of the company's mobile wallet is accepted across India. The logo of Paytm is now popular almost everywhere from tea stalls to major companies.

Say

- Let's see what qualities made Vijay Shekhar Sharma a resilient entrepreneur.
- Discuss Entrepreneurship and Resilience with the participants as given in the Participant Handbook.

Say

- Let's learn more about entrepreneurship and resilience with the help of an activity.

Team Activity

Entrepreneurship and Resilience

- This is a group activity.
- Think of some entrepreneurship ventures that faced challenging times, but later resulted in success stories.
 - Who is the founder of that company?
 - What challenging times did it face?
 - How did it overcome those challenges?
 - List the resilient characteristics of the entrepreneur.

Activity De-brief

- Each group to give their presentation.
- Why did you choose this company?
- What is the success story of the company?

Do

- Instruct the participants that this is group work.
- Divide the class into small groups of 4.
- Give each group a chart paper.
- Tell the participants that they have to think of an entrepreneur who faced challenging times, but eventually succeeded.
- Give the participants 15 minutes to discuss and write.
- Keep a check on time. Tell the group to wind up quickly if they go beyond the given time limit.

Summarize

- You can summarize the key points of the unit.
- Ask the participants what they learned from the activities.
- Clarify any questions or doubts they might have.

UNIT 9.5.8: Success and Failures

Unit Objectives

At the end of this unit, participants will be able to:

- Discuss how to deal with failure

Resources to be Used

- Participant Handbook

Ask

- Have you heard the quote 'nothing is impossible'?
- What do you think it means?
- Do you think that all successful entrepreneurs became famous overnight or did they have to struggle or face failure before succeeding?

Example

- Let's have a look at this example.

Shah Rukh Khan, also known as, SRK or King Khan is a force to reckon with. Did he achieve stardom overnight? Shah Rukh Khan, who has seen many struggles in his life – he has slept on streets, struggled to support himself and his sister at a very young age, and lost his parents very early in life, which led to his sister seeking mental health support. Amidst all the chaos and challenges, he kept pushing himself, and today he stands tall as the 'Badshah of Bollywood'. Certainly those years were not easy for him.

When he was young, he stood at Marine Drive and said, "I will rule this city one day". Failure was not just his companion during or before his stardom, it is still a substantial part of his life. Success does not come easy. What made him a star was his acceptance of failure and the urge to improve.

Say

- How do you define success and failure?
- What is fear?
- Discuss "success and failure" with the participants as given in the Participant Handbook.

Ask

- Have you felt or experienced fear?
- What led you to feel that emotion?
- How did you handle it?

Say

- Let's learn the about success and failure with the help of an activity.

Team Activity

- Divide the class into groups of four.
- Instruct them to think of one scenario where they have to interview a successful entrepreneur.
- Explain the purpose and duration of the activity.
- Set guidelines pertaining to discipline and expected tasks.
- They have to choose one person from the group as the interviewee and one as the interviewer.
- Go around and make sure they have understood what is to be done and are discussing the roles properly.
- Check that everyone understands their role. Give clarifications if needed. Give the participants about 5 minutes to discuss and decide their roles.
- Ask the groups to stop the discussion as soon as the time is over.
- Invite each group one by one to come and present their interview as a role play.

Notes for Facilitation

Facilitating Role Plays

Preparing for the activity

1. Carefully review the details of the scenario and the character descriptions.
2. Become familiar with the key issues being addressed in the scenario.
3. Study the provided material so that you are ready to address issues related to the situations depicted in the role plays.
4. Anticipate potential questions that might be raised by the participants and be ready to address them.

Conducting the activity

1. Introduce the activity. Emphasize that role playing provides participants with an opportunity to apply their new knowledge, skills, and tools in situations that simulate actual interactions with customers.
2. Ask participants to form pairs. Direct the members of each group to choose who will play the roles. Remind the groups that each participant should be given the opportunity to play/practice the different roles.
3. Conduct a demonstration so that participants become familiar with the expectations related to the roles and support materials.
4. To maintain spontaneity of the interactions during the role play, ask the participants not to discuss the details of their roles prior to the role play.
5. Give the pairs 15-20 minutes to conduct the role play.
6. Circulate among the groups to answer any questions that may arise and provide guidance as needed.
7. After all the pairs have finished with the role play, conduct a de-briefing session on each role play.
8. Ask the groups to take five minutes to talk about what happened during the role play. The groups should discuss the questions given in the de-briefing for each role play. Encourage participants to provide constructive criticism during their discussions.
9. Conclude the activity by asking participants to think about whether and how they might use scripted role plays in their real life.

Summarize

- Wrap the unit up after summarizing the key points and answering questions.

UNIT 9.6: Preparing to be an Entrepreneur

Key Learning Outcomes



At the end of this unit, participants will be able to:

1. Discuss how market research is carried out
2. Describe the 4 Ps of marketing
3. Discuss the importance of idea generation
4. Recall basic business terminology
5. Discuss the need for CRM
6. Discuss the benefits of CRM
7. Discuss the need for networking
8. Discuss the benefits of networking
9. Discuss the importance of setting goals
10. Differentiate between short-term, medium-term and long-term goals
11. Discuss how to write a business plan
12. Explain the financial planning process
13. Discuss ways to manage your risk
14. Describe the procedure and formalities for applying for bank finance
15. Discuss how to manage their own enterprise
16. List the important questions that every entrepreneur should ask before starting an enterprise

UNIT 9.6.1: Market Study/ The 4Ps of Marketing/ Importance of an IDEA: Understanding Market Research

Unit Objectives

At the end of this unit, participants will be able to:

- Discuss how market research is carried out
- Describe the 4 Ps of marketing
- Discuss the importance of idea generation

Resources to be Used

- Participant Handbook
- Chart papers
- Markers pens
- Blank sheets of paper

Ask

- Suppose, you want to open a restaurant, what are the factors you will consider?
- How will you promote your restaurant?

Example

- Let's have a look at this example.

Arjun was an MBA working in a company. But he wanted to start a low cost budget hostel for foreign tourists coming to India. He did a lot of market research before starting the project. Based on the information he gathered, he made his business plan. His hostel is now flourishing and he is thinking of expanding to other tourist destinations.

Say

- Discuss “Market Study” with the participants. Refer to the Participant Handbook.
- Let's learn about market study and research with the help of an activity.

Team Activity

Market Study

- This is a group activity.
- You want to start your own tuition centre.
- What type of research will you do?

Activity De-brief

- Ask each group to come forward and give a brief presentation.
- Encourage other groups to be interactive and ask questions.
- What factors did you keep in mind while doing your research?
- Based on our research would you go ahead and open a tuition centre?

Do 

- Instruct the participants that this is group work.
- Divide the class into small groups of 4 or 6.
- Give each group a chart paper.
- Tell the participants that they have to start their own tuition centre.
- Give the participants 10 minutes to discuss and write the research work they need to do.
- Keep a check on time. Tell the group to wind up quickly if they go beyond the given time limit.

Say 

- By opening a tuition centre you are offering a service.

Ask 

- What factors will you keep in mind before opening it?

Say 

- Discuss “The 4Ps of Marketing” with the participants as given in the Participant Handbook.

Say 

- Let's learn about the 4Ps of Marketing with the help of an activity.

Team Activity **4 Ps of Marketing**

- This is a group activity.
- You have to sell a pen to four different segments:
 1. Rural villagers
 2. Rural middle class
 3. Urban middle class
 4. Upper end rich people (Niche market)

Keeping the 4Ps of Marketing in mind, what marketing strategy will you design to sell the pen?

Activity De-brief

- Ask each group to present their strategy.
- Encourage other groups to be interactive and ask questions.

Do 

- Instruct the participants that this is group work.
- Divide the class into four groups.
- Give each group a chart paper.
- Assign each group a target audience for selling the pens:
 1. Rural villagers
 2. Rural middle class
 3. Urban middle class

4. Upper end rich people

- Tell the participants that they have to design a marketing strategy keeping the 4Ps of Marketing in mind.
- Give the participants 20 minutes to discuss and come up with their strategy.
- Keep a check on time. Tell the group to wind up quickly if they go beyond the given time limit

Activity De-brief

- Ask each group to come forward and give a brief presentation.
- Ask each group what they kept in mind while designing their marketing strategy.
- Encourage other groups to be interactive and ask questions.

Say

- Each entrepreneur has an idea of wants he wants to sell. It may be a service or a product.
- Discuss “Importance of an IDEA” as given in the Participant Handbook.

Summarize

- Summarize the key points of the unit.
- Ask the participants what they learnt from the activities.
- Encourage them to ask if they have any doubts.

UNIT 9.6.2: Business Entity Concepts

Unit Objectives

At the end of this unit, participants will be able to:

- Recall basic business terminology

Resources to be Used

- Participant Handbook

Say

- Let's recall some basic business terminology.
- Discuss the Business Entity Concepts as given in the Participant Handbook.
- Let's learn some basic business terminology by having an activity.
- We will have a quiz today.

Activity

- The activity is a quiz.

Do

- Divide the class in two groups and give a name to each group.
- Explain the rules of the quiz. For each correct answer the group gets 1 mark.
- If the group is unable to answer the question is passed to the next group.
- Explain the purpose and duration of the activity.
- Ask the questions of the quiz.
- Keep a score of the groups.
- Set guidelines pertaining to discipline and expected tasks.

Summarize

- Summarize the unit by discussing the key points.

Notes for Facilitation

QUESTIONS FOR THE QUIZ

1. What does B2B mean?
Business to business
2. What is a financial report?
A comprehensive account of a business' transactions and expenses
3. Who is a sales prospect?
A potential customer
4. How is working capital calculated?
Current assets minus current liabilities

5. What is an estimation of the overall worth of a business called?
Valuation
6. You are buying a house. What type of transaction is it?
Complex transaction
7. How will you calculate the net income?
Revenue minus expenses
8. How is Return on Investment expressed?
As percentage
9. How will you calculate the cost of goods sold?
Cost of materials minus cost of outputs
10. What is revenue?
Total amount of income before expenses are subtracted.
11. What is a Break-Even Point?
This is the point at which the company will not make a profit or a loss. The total cost and total revenues are equal.
12. What is the formula used to calculate simple interest?
 $A = P(1 + rt); R = r * 100$
13. What are the three types of business transactions?
Simple, Complex and Ongoing Transactions
14. The degrading value of an asset over time is known as
Depreciation
15. What are the two main types of capital?
Debt and Equity

UNIT 9.6.3: CRM & Networking

Unit Objectives

At the end of this unit, participants will be able to:

- Discuss the need for CRM
- Discuss the benefits of CRM
- Discuss the need for networking
- Discuss the benefits of networking

Resources to be Used

- Participant Handbook

Ask

- Can your business run without customers/buyers?
- Who is the most important entity in any business?

Say

- The key to every success business lies on understanding the customer's expectations and providing excellent customer service.
- Discuss about CRM and its benefits. Refer to the Participant Handbook.
- Providing excellent customer service entails:
 - ♦ Treating your customers with respect.
 - ♦ Be available as per their need/ schedule.
 - ♦ Handling complaints effectively.
 - ♦ Building long lasting relationships.
 - ♦ Collecting regular feedback.
- Handle customer complaints proactively. Ask “what happened”, “why it happened”, “how can it be avoided next time”, etc.
- Collecting feedback from the customers regularly will enable you to improve your good/service.
- “Let's understand it better with the help of some case scenarios. You will be given some cases within your groups. You have to analyse the case scenario that has been given to you and then find an appropriate solution to the problem.”

Do

- Divide the class into four groups of maximum six participants depending on the batch size.
- Give one case study to each group.
- Instruct them to read the case carefully.
- The group is expected to analyse and discuss the case amongst them and find a solution to the given problem.
- Put down the discussion points (de-brief questions) on the board. Give the class 5-10 minutes to discuss the case and note down their solutions.
- At the end of 10 minutes, the team should present their case solution to the class.

Team Activity

Case Study Analysis

Raju runs a business of wooden furniture. He has a huge list of customers on Facebook and WhatsApp who give him orders regularly. Ankita is one of his old and regular customers. She placed an order for a new chester and TV cabinet via WhatsApp and requested Raju to send them as soon as possible. When the parcel reached Ankita through courier she found that chester was broken and the TV unit was chipped from the bottom. Ankita was heartbroken. It was a complete waste of money. She sent a message to Raju on WhatsApp, expressing her anger and disappointment. Raju might lose an old customer forever if he doesn't satisfy the customer. What should Raju do to retain his customer?

Scenario 2

Rajni runs a boutique shop. She sells suits and sarees. She is one of the most successful designer in her city. Rajni swears that all the clothes in her boutique have unique designs. Smita has to attend her cousin's wedding; she goes to Rajni's boutique to buy a saree. Smita wanted a unique designer saree. Rajni customized a saree for her and sent it over the courier. When Smita had a look at the saree she realised her two friends had the same design sarees. She sent a message to Rajni on WhatsApp, expressing her anger and disappointment. Did Rajni make a false promise? Were her designs copied? What could happen to Rajni's image after this incident? What would you do if you were in Rajni's place?

Scenario 3

Shama is a beautician who offers parlour services to ladies by making home visits. Recently, Shama got her name registered on an e-commerce website. Two days earlier, she got a message from Mrs Sushma. The appointment was fixed for next day, 11:00 am and the remuneration for the services was decided beforehand. When Shama reached there at 10:50 am, Mrs Sushma was not at home. When Shama called her, she asked her to wait for a while. Mrs Sushma reached home at 11:45 am. Meanwhile, Shama had to reschedule her next appointment. After availing Shama's services, Mrs Sushma refused to pay the requisite amount and started finding faults in the services provided by her. Who was at fault in this scenario? What should you do in case the customer behaves unreasonably? What would you do if you were in Shama's place?

Scenario 4

Shailender is the manager of a car showroom. He proactively takes part in all the transactions that happen in his showroom. Vinita wants to buy a new car. She has chosen a car from Shailender's showroom. The salesperson has given her a very good discount and has also promised free service for one year. Vinita goes to the showroom and asks to complete all the formalities to purchase the car. When she sees the final bill she realize that she has not received the promised discount neither was there any mention of the free services. She immediately demands to see the Shailender. When Shailender's head asks how much discount Vinita was promised, he realised the discount will make the sale in loss. The car showroom owner might lose a customer and deal due to false commitments made by his manager. Besides, the customer might tell this to other people, creating a bad name and image for the showroom. If you owned that showroom, how would you have convinced your customer?

Say

- Now, let's discuss the problem and solution with the class.
- The group will first briefly describe the case to the class.
- Then discuss the issue identified and the proposed solution.
- Present the solution as a role play.
- Post presentation, the other groups may ask questions from the group that has presented.

Do 

- Congratulate each group for the presentation/ role play.
- Ask the audience to applaud for them.
- Keep a check on time. Tell the group to wind up the discussion quickly if they go beyond the given time limit.

Say 

- If your customers are happy with you they will give referrals which will help to grow your business.
- One more way of growing business is 'Networking'.
- Discuss Networking and its benefits. Refer to the Participant Handbook.

Activity 

Group Discussion

- Conduct a group discussion in the class on how they can do networking for their business.

Summarize 

- Ask the participants what they have learnt from this exercise/ activity.
- Ask if they have any questions related to what they have talked about so far.
- Close the discussion by summarizing the importance of CRM and Networking for entrepreneurs.
- Close the discussion by summarizing the importance of CRM and Networking for entrepreneurs.

UNIT 9.6.4: Business Plan: Why Set Goals?

Unit Objectives

At the end of this unit, participants will be able to:

- Discuss the importance of setting goals
- Differentiate between short-term, medium-term and long-term goals
- Discuss how to write a business plan
- Explain the financial planning process
- Discuss ways to manage your risk

Resources to be Used

- Participant Handbook
- Chart papers
- Blank papers
- Marker pens
- Ruler

Ask

- Remember we had written SMART Goals in a previous session? Let's try and recall why it is important to set goals?
- While framing SMART goals, we talked about 'T' in SMART, which was 'Time Bound'? What do we mean by time bound goals?
- What time limit did you set for your goal- 3 weeks, 3 years, 10 years?

Say

- Talk about short term, long term and medium term goals, as discussed in the Participant Handbook.

Ask

- As you are planning to become an entrepreneur, you must have thought of an idea for a start-up. What is your business idea?

Do

- Ask few participants to share their business ideas.

Ask

- Have you created a business plan for your business idea?
- Do you think it is important to have a business plan in place? Why/ why not?

Say

- Talk about 'Why Create a Business Plan' as discussed in the Participant Handbook.
- Let's understand it better with the help of an activity.

Team Activity

Writing a business Plan

- This is a group activity.
- Give the groups the required resources such as chart paper and markers.
- This activity is divided into two parts:
 1. Create a business idea
 2. Develop a business plan
- The group will discuss and come up with a new business idea and present their idea to the class.
- In the second part of the activity the group will develop a business plan for the business idea.
- The business plan prepared will be presented by the groups to the class.

MY BUSINESS PLAN
Executive Summary: What is your Mission Statement?
Business Description: What is the nature of your business?
Market Analysis: What is your target market?
Organization and Management: What is your company's organizational structure?
Service or Product Line: What is the lifecycle of your product/ service?
Marketing and Sales: How will you advertise and sell your products?
Funding Request: How much fund is required and from where?

Say

- Teams will need to brainstorm for this part of the activity.
- Use the blank papers for the second part of this activity
- Make your business plan on a chart paper based on the following parameters:
 1. Executive Summary
 2. Business Description
 3. Market Analysis
 4. Organization and Management
 5. Service or Product Line
 6. Marketing and Sales
- Explain each parameter in detail as done in the Participant Handbook.
- Discuss each parameter with the business idea examples of the groups.
- Groups will discuss and develop the business plan for their business idea.

Say 

- Now, let's share our plan with the class.
- Each group will briefly describe the plan to the class.
- Post presentation, the other groups may ask questions to the group who have presented their plan.

Do 

- Congratulate each group for sharing their points.
- Ask the audience to applaud for them.
- Keep a check on time. Tell group to wind up the discussion quickly if they go beyond the given time limit.

Say 

- Along with a business plan, you need to create a financial plan and evaluate the risk involved with your start up.
- Discuss 'Financial Planning' and 'Risk Management' in detail as given in the Participant Handbook.

Summarize 

- Ask the participants what they have learnt from this exercise/ activity.
- Ask if they have any questions related to what they have talked about so far.

Notes for Facilitation 

- Keep the business plan format ready in a flipchart to display it during the activity.

UNIT 9.6.5: Procedures and Formalities for Bank Finance

Unit Objectives

At the end of this unit, participants will be able to:

- Describe the procedure and formalities for applying for bank finance

Resources to be Used

- Participant Handbook
- Bank loan/finance form sample

Ask

- While preparing a business plan in the last session, we discussed financial planning to arrange financial resources for your start-up. Therefore, how will you collect funds to start your business?

Say

- While most entrepreneurs think 'product' is the most difficult thing to decide for a business, start-up capital poses an even a bigger obstacle. Though there are various ways of funding the business, to convince investors to invest money is the most challenging.
- Some of the funding options available in India are:
 - ♦ **Bootstrapping:** Also called self-financing is the easiest way of financing
 - ♦ **Crowd funding:** Funds are collected by consumers pre-ordering or donating for starting the business.
 - ♦ **Angel investors:** Individual or group of investors investing in the company
 - ♦ **Venture capitalists:** Venture capitals are professionally managed funds who invest in companies that have huge potential. They usually invest in a business against equity.
 - ♦ **Bank loans:** The most popular method in India.
 - ♦ **Microfinance Providers or NBFCs**
 - ♦ **Government programmes**
- Let us know discuss the most popular method i.e. bank finance in detail here.

Do

- Discuss the list of documents that are required to apply for a loan like letter of introduction, business brochure, references of other banks, and financial statements.
- Explain the details to be filled in a loan application form.
- Divide the class into groups. Give each group a loan application form.
- Ask the groups to discuss and fill the form.

Summarize

- Close the discussion by summarizing the important documents needed for bank loan.
- Ask the participants if they have any questions related to what they have talked about so far.

Notes for Facilitation

- Checklist of documents is provided as resources for the session.
- You can make some copies and distribute it during the group activity.
- Download sample loan application forms from any nationalised bank's website. Print sufficient copies to circulate it amongst the groups.

CHECKLIST OF DOCUMENTS TO BE SUBMITTED ALONG WITH LOAN APPLICATION (Common for all banks)
1. Audited financial statements of the business concern for the last three years
2. Provisional financial statements for the half – year ended on _____
3. Audited financial statements of associate concern/s for the last three years
4. Copy of QIS II for the previous quarter ended on _____
5. Operational details in Annexure I
6. CMA data for the last three years, estimates for current year and projection for the next year
7. Term loan/DPG requirements in Annexure II
8. List of machinery in respect of machinery offered as security in Annexure III
9. Additional details for export advances furnished in Annexure IV
10. Property statements of all directors/partners/proprietor/guarantors
11. Copies of ITAO of the company for the last three years
12. Copies of ITAOs/WTAOs of the directors/partners/proprietor and guarantors
13. Copies of certificate from banks and financial institutions certifying the latest liability with them
14. Copy of board resolution authorizing the company to apply to your bank for the credit facilities mentioned in application
15. Copy of memorandum and article of association (in case of limited company)/partnership deed (in case of partnership firm)
16. Cash budget for the current year and next year in case of contractors and seasonal industries

UNIT 9.6.6: Enterprise Management – An Overview: How to Manage Your Enterprise?

Unit Objectives

At the end of this unit, participants will be able to:

- Discuss how to manage their own enterprise

Resources to be Used

- Participant Handbook

Ask

- Having set-up a business, do you think it is possible to do everything on your own?
- Does one require trained persons for help?
- What does management mean?

Say

- Let's have a look at this example:

Kapil had a small business that was beginning to pick up pace. He wanted to expand his business, and therefore employed few more people. One day, as he was walking past Ramesh, one of his new employees, he overheard Ramesh talking rudely to a customer on the phone. This set him thinking. Kapil realised that he should have regular team meetings to motivate his employees and speak with them about any problems they might be facing during work. He should also conduct training sessions on new practices, soft skills, and technology, and develop work ethics manual for managing his enterprise.

Say

- Was Kapil correct in his approach or he should have scolded Ramesh instantly in front of his other employees?
- Discuss “Enterprise Management – An Overview” with the participants as given in the Participant Handbook.

Say

- Let's learn how to effectively manage an enterprise or business through an activity.

Team Activity

Enterprise Management

- This is a group activity.
- Design a matrix listing the topics and key words that are needed to run an enterprise effectively and smoothly.

Activity De-brief

- Have each group present their matrix.
- Encourage participants of the other groups to ask question about each other's presentation.

Do

- Instruct the participants that this is group work.
- Divide the class into small groups of 4.
- Give each group a chart paper and coloured pen.
- Tell the participants that they have make a matrix they need to fill.
- They have to write the main topics and key words that will them effectively manage their enterprise.
- Give the participants 15 minutes to discuss and write.
- Keep a check on time. Tell the group to wind up quickly if they go beyond the given time limit.

Summarize

- Ask the participants what they have learned from this exercise/activity.
- Ask if they have any questions related to what they have talked about so far.
- Close the discussion by summarizing the importance of effective management to run an enterprise as given in the Participant Handbook.

UNIT 9.6.7: 20 Questions to Ask Yourself before Considering Entrepreneurship

Unit Objectives

At the end of this unit, participants will be able to:

- List the important questions that every entrepreneur should ask before starting an enterprise

Resources to be Used

- Participant Handbook
- Blank sheets of paper
- Pens

Ask

- Why do you want to become an entrepreneur?

Say

- It is very important to know why you want to become an entrepreneur. Your personal goals for becoming an entrepreneur play a key role in the success of your business. Your goals should be clear well before you start your business.
- Apart from the goals, the other aspects of business that you need to bear in mind are the potential problems that you may face to set-up, your areas of interest, and all the other dimensions of the business.
- Let's understand it better with the help of some questions that every entrepreneur should ask before starting their own business.
- Open the Participant Handbook section named '20 Questions to Ask Yourself Before Considering Entrepreneurship'. You have to answer the questions individually.
- Then, we will have a class discussion on all the questions.

Do

- Read out the questions one by one in front of all the participants.
- Participants have to answer all the one by one questions.
- Give the class 10-15 minutes to note down their answers.
- At the end of 15 minutes, open the discussion for all the questions.
- Moderate the discussion by focusing on the relevant points.
- Keep a check on time and don't let the discussion get sabotaged or lose track of time. Ensure all the questions are covered and discussed.

Summarize

- Ask the participants what they have learned from this exercise/activity.
- Ask if they have any questions related to what they have talked about so far.



Skill India
शिक्षणं मरणं - कृषणं मरणं



GOVERNMENT OF INDIA
MINISTRY OF SKILL DEVELOPMENT
& ENTREPRENEURSHIP



N S D C
National
Skill Development
Corporation

Transforming the skill landscape



10. Annexures

Annexure I: Training Delivery Plan

Annexure II: Assessment Criteria



Annexure I

Training Delivery Plan

Training Delivery Plan			
Program Name:	Self Employed Tailor		
Qualification Pack Name & Ref. ID	AMH/Q1947		
Version No.	1.0	Version Update Date	21/03/18
Pre-requisites to Training	NA		
Training Outcomes	<p>By the end of this program, the participants will be able to:</p> <ol style="list-style-type: none"> 1. Draft and cut the fabric 2. Carry out the process of sewing for dress materials and common household items of textiles 3. Carry out inspections and alterations to adjust corrections for fittings 4. Maintain health, safety and security in the tailoring shop 5. Maintain work area, tools and machines 6. Comply with industry, regulatory and organizational requirements 		

Sl. No.	Module Name	Session Name	Session Objectives	NOS Reference	Methodology	Training Tools/Aids	Duration
1.	Orientation and Introduction	Apparel Industry	Theory 1. Overview of Apparel Industry	Bridge Module	<ul style="list-style-type: none"> Facilitator-led – Discussion 	PPT, Participant Handbooks, Audio Visual Clips	1:00 hrs.
		Roles and responsibilities of a Tailor	Theory 1. Job Description of a Tailor 2. Roles and responsibilities of Tailor	Bridge Module	<ul style="list-style-type: none"> Power-point presentation Facilitator-led - discussion Audio-visuals Images 	PPT, Handbooks, Audio Visual Clips	1:00 hrs.
2.	Drafting & Cutting the Fabric	Tools & Equipment required for Tailoring	Theory 1. Orient towards the different types of material and tools used in stitching 2. Create an understanding of various stitching terms	AMH/N1947	<ul style="list-style-type: none"> Power-point presentation Facilitator-led - discussion Audio-visuals clips 	Participant Handbook, Notebook, Various tools & material in stitching, pen, duster, white board, marker, Computer, Projector, etc.	2:00 hrs.
			Practical <ul style="list-style-type: none"> Identification of material & tools required for stitching 	AMH/N1947	<ul style="list-style-type: none"> Practical Lab 	Note Pad, Pen, Various tools & material in stitching	4:00 hrs.
		Types of Fabric	Theory 1. Familiarize with different types of fabric 2. Familiarize with fabric-needle-thread compatibility	AMH/N1947	<ul style="list-style-type: none"> Power-point presentation Facilitator-led – discussion Audio-visual Clips 	Participant Handbook, Notebook, Fabric swatch file, different gauge needles, different gauge thread, pen, duster, white board, marker, Computer, Projector, etc.	3:00 hrs.
			Practical <ul style="list-style-type: none"> Identification of different fabrics 	AMH/N1947	<ul style="list-style-type: none"> Facilitator led question answer session 	Fabric swatch file, Notebook, Pen, Participant Handbook	4:00 hrs.
		Trims and Accessories	Theory 1. Familiarize with trims and accessories 2. Create an understanding of importance and usage of various trims and accessories	AMH/N1947	<ul style="list-style-type: none"> Power-point presentation Facilitator-led – discussion Audio-visual Clips 	Participant Handbook, Trims file, Notebook, Pen, Duster, White board, marker, Computer, Projector, etc.	3:00 hrs.
			Practical <ul style="list-style-type: none"> Method of sewing different trims and accessories 	AMH/N1947	<ul style="list-style-type: none"> Demonstration in the practical lab 	Trims file, Sewing Machine, Thread, Bobbin, Bobbin Case, Hand Needles, scissors, Notebook, Pen, Participant Handbook	6:00 hrs.
		Size Chart	Theory 1. Orient towards different size chart comparison tables 2. Orient towards different terms used in size charts	AMH/N1947	<ul style="list-style-type: none"> Power-point presentation Facilitator-led – discussion Audio-visual Clips 	Participant Handbook, Notebook, Various Size charts, pen, duster, white board, marker, Computer, Projector, etc.	3:00 hrs.
			Practical <ul style="list-style-type: none"> Create an understanding of using the measuring tape 	AMH/N1947	<ul style="list-style-type: none"> Demonstration in Practical Lab Facilitator led question answer 	Note Pad, Pen, measuring tape, Participant Handbook/ Facilitator Guide	4:00 hrs.

		Taking Measurements	<p>Theory</p> <p>1. Measurements associated with different garments</p>	AMH/N1947	<ul style="list-style-type: none"> • Power-point presentation • Facilitator-led – discussion • Audio-visual Clips 	Participant Handbook, Notebook, Various Garments , pen, duster, white board, marker, Computer, Projector, etc.	3:00 hrs.
			<p>Practical</p> <ul style="list-style-type: none"> • Taking measurements for different garments 	AMH/N1947	<ul style="list-style-type: none"> • Demonstration in Practical Lab 	Note Pad, Pen, measuring tape, mannequin, dress form, various garments	10:00 hrs.
		Drafting & Cutting	<p>Theory</p> <p>1. Create an understanding of different drafting techniques</p>	AMH/N1947	<ul style="list-style-type: none"> • Power-point presentation • Facilitator-led – discussion • Audio-visual Clips 	Participant Handbook, Notebook, Drafting tools, Pattern paper, Measuring Tape, Dress form, pen, duster, Fabric, white board, marker, Computer, Projector, etc.	3:00 hrs.
			<p>Practical</p> <ul style="list-style-type: none"> • Learn drafting & cutting of Saree Blouse 	AMH/N1947	<ul style="list-style-type: none"> • Facilitator led demonstration • Show different techniques • Prepare test fits to demonstrate factors affecting fits 	Participant Handbook, Notebook, Drafting tools, Pattern paper, Measuring Tape, Dress form, pen, duster, white board, marker, Computer, Projector, etc.	10:00 hrs.
			<p>Practical</p> <ul style="list-style-type: none"> • Practice drafting and cutting of Saree Blouse to achieve desired speed and quality 	AMH/N1947	<ul style="list-style-type: none"> • Practice sessions to remember and perfect the techniques and achieve desired fit 	Participant Handbook, Notebook, Drafting tools, Pattern paper, Measuring Tape, Dress form, pen, duster, Fabric, white board, marker, Computer, Projector, etc.	10:00 hrs
			<p>Practical</p> <ul style="list-style-type: none"> • Drafting & Cutting of Kurta/ Kameez 	AMH/N1947	<ul style="list-style-type: none"> • Facilitator led demonstration • Show different techniques • Prepare test fits to demonstrate factors affecting fits 	Participant Handbook, Notebook, Drafting tools, Pattern paper, Measuring Tape, Dress form, pen, duster, white board, Fabric, marker, Computer, Projector, etc.	10:00 hrs.
			<p>Practical</p> <ul style="list-style-type: none"> • Practice drafting and cutting of Kurta/Kameez to achieve desired speed and quality 	AMH/N1947	<ul style="list-style-type: none"> • Practice sessions to remember and perfect the techniques and achieve desired fit 	Participant Handbook, Notebook, Drafting tools, Pattern paper, Measuring Tape, Dress form, pen, duster, white board, marker, Computer, Projector, etc.	10:00 hrs
			<p>Practical</p> <ul style="list-style-type: none"> • Drafting & Cutting of Pant 	AMH/N1947	<ul style="list-style-type: none"> • Facilitator led demonstration • Show different techniques • Prepare test fits to demonstrate factors affecting fits 	Participant Handbook, Notebook, Drafting tools, Pattern paper, Measuring Tape, Dress form, pen, duster, white board, marker, Computer, Projector, etc.	10:00 hrs.
			<p>Practical</p> <ul style="list-style-type: none"> • Practice drafting and cutting of Pant to achieve desired speed and quality 	AMH/N1947	<ul style="list-style-type: none"> • Practice sessions to remember and perfect the techniques and achieve desired fit 	Participant Handbook, Notebook, Drafting tools, Pattern paper, Measuring Tape, Dress form, pen, duster, white board, marker, Computer, Projector, etc.	10:00 hrs

		Types of Fabric Defects	<p>Theory</p> <ol style="list-style-type: none"> 1. Familiarize with the concept of quality 2. Familiarize with different categories of defects 	AMH/N1947	<ul style="list-style-type: none"> • Power-point presentation • Facilitator-led – discussion 	Fabric defect swatch file, Notebook, Pen, Participant Handbook duster, white board, marker, Computer, Projector, etc.	3:00 hrs.
			<p>Practical</p> <ul style="list-style-type: none"> • Identification of various defects 	AMH/N1947	<ul style="list-style-type: none"> • Practical Lab 	Fabric defect swatch file	6:00 hrs.
			<p>Practical</p> <ul style="list-style-type: none"> • Rectification of Sewing Defects 	AMH/N1947	<ul style="list-style-type: none"> • Practical Lab 	Fabric defect swatch file	6:00 hrs.
		Establishing Learner's Understanding	<ul style="list-style-type: none"> • Ensure learning confirmation 	Bridge Module	<ul style="list-style-type: none"> • Facilitator led question-answer session • Gauge the learner for their understanding & proficiency of the module • Process based gauging to map learning curve 	Notepad, Fabric, Garment Patterns, Pencil, Pen, Participant Handbook/Facilitator Guide	-
3.	The Sewing Process	The Sewing Process	<p>Theory</p> <ol style="list-style-type: none"> 1. Parts of a Sewing Machine and its importance 	AMH/N1948	<ul style="list-style-type: none"> • Facilitator-led – Discussion • Use images and description given in the Participant's Handbook 	PPT, Participant Handbook, Audio Visual Clips, Sewing Machine	3:00 hrs.
			<p>Theory</p> <ol style="list-style-type: none"> 1. Different types of Sewing Machine and their features 	AMH/N1948	<ul style="list-style-type: none"> • Facilitator-led – Discussion • Use images and description given in the Participant's Handbook 	PPT, Participant Handbook, Audio Visual Clips, Sewing Machine	3:00 hrs.
			<p>Practical</p> <ul style="list-style-type: none"> • Identification of Different Machine Parts • Precautions to be taken while setting and using a sewing machine 	AMH/N1948	<ul style="list-style-type: none"> • Facilitator-led questions answer sessions • Demonstration using a sewing machine 	PPT, Participant Handbook, Audio Visual Clips, Sewing Machine	1:00 hrs.
			<p>Practical</p> <ul style="list-style-type: none"> • Threading a sewing machine 	AMH/N1948	<ul style="list-style-type: none"> • Facilitator-led questions answer sessions • Demonstration using a sewing machine 	PPT, Participant Handbook, Audio Visual Clips, Sewing Machine, Thread, Bobbin, Bobbin case, needle, Notebook, Pen	4:00 hrs.
			<p>Practical</p> <ul style="list-style-type: none"> • Understand and learn different hand sewing methods 	AMH/N1948	<ul style="list-style-type: none"> • Demonstration • Orient towards which needle to use for a desired effect/fabric 	PPT, Participant Handbook, Audio Visual Clips, Sewing Kit, Thread, Hand needle, Notebook, Pen, Fabric	4:00 hrs.
			<p>Practical</p> <ul style="list-style-type: none"> • Sequence of sewing a basic apron with pocket 	AMH/N1948	<ul style="list-style-type: none"> • Demonstration in Practical Lab 	Participant Handbook, Sewing Machine, Thread, Bobbin, Bobbin case, needle, Fabric, Notebook, Pen	8:00 hrs.
		Stitching	<p>Theory</p> <ol style="list-style-type: none"> 1. Recognize the different parts of basic garments (Trouser & Shirt) 	AMH/N1948	<ul style="list-style-type: none"> • Trainer led discussion • Identification of garment parts using a garment 	PPT, Participant Handbook, Audio Visual Clips, Various Garments (Trouser, shirt etc)	3:00 hrs.

			<p>Theory</p> <p>1. Different seams and stitches in garments</p>	AMH/N1948	<ul style="list-style-type: none"> Power-point presentation Facilitator-led - discussion Audio-visuals Clips 	PPT, Computer, Projector, Seam swatch file, Notebook, Pen	3:00 hrs.
			<p>Theory</p> <p>1. Trims and accessories used in different garments</p>	AMH/N1948	<ul style="list-style-type: none"> Power-point presentation Facilitator-led - discussion Audio-visuals Clips 	PPT, Computer, Projector, Trim & accessory specimen, Notebook, Pen	3:00 hrs.
			<p>Theory</p> <p>1. Stitching sequence of a Trouser</p>	AMH/N1948	<ul style="list-style-type: none"> Power-point presentation Facilitator-led - discussion 	Participant Handbook, Trouser, Trouser Pattern, Notebook, Pen, PPT, Projector, Computer, etc.	3:00 hrs.
			<p>Practical</p> <ul style="list-style-type: none"> Learn & Practice to stitch a Trouser 	AMH/N1948	<ul style="list-style-type: none"> Demonstration in Practical Lab 	Participant Handbook, Sewing Machine, Thread, Bobbin, Bobbin case, needle, Fabric, Notebook, Pen	8:00 hrs.
			<p>Theory</p> <p>1. Stitching sequence of a Shirt</p>	AMH/N1948	<ul style="list-style-type: none"> Power-point presentation Facilitator-led - discussion 	Participant Handbook, Shirt, Shirt Pattern, Notebook, Pen, PPT, Projector, Computer, etc.	3:00 hrs.
			<p>Practical</p> <ul style="list-style-type: none"> Learn & Practice to stitch a Shirt 	AMH/N1948	<ul style="list-style-type: none"> Demonstration in Practical Lab 	Participant Handbook, Sewing Machine, Thread, Bobbin, Bobbin case, needle, Fabric, Notebook, Pen	8:00 hrs.
			<p>Theory</p> <p>1. Stitching sequence of a Saree Blouse</p>	AMH/N1948	<ul style="list-style-type: none"> Power-point presentation Facilitator-led - discussion 	Participant Handbook, Blouse, Blouse Pattern, Notebook, Pen, PPT, Projector, Computer, etc.	3:00 hrs.
			<p>Practical</p> <ul style="list-style-type: none"> Learn & Practice to stitch a Saree Blouse 	AMH/N1948	<ul style="list-style-type: none"> Demonstration in Practical Lab 	Participant Handbook, Sewing Machine, Thread, Bobbin, Bobbin case, needle, Fabric, Notebook, Pen	8:00 hrs.
			<p>Theory</p> <p>1. Stitching sequence of a Kurta/Kameez</p>	AMH/N1948	<ul style="list-style-type: none"> Power-point presentation Facilitator-led - discussion 	Participant Handbook, Kurta/Kameez, Kurta/Kameez Pattern, Notebook, Pen, PPT, Projector, Computer, etc.	3:00 hrs.
			<p>Practical</p> <ul style="list-style-type: none"> Learn & Practice to stitch a Kurta/Kameez 	AMH/N1948	<ul style="list-style-type: none"> Demonstration in Practical Lab 	Participant Handbook, Sewing Machine, Thread, Bobbin, Bobbin case, needle, Fabric, Notebook, Pen	8:00 hrs.
			<p>Practical</p> <ul style="list-style-type: none"> Stitching button and button holes 	AMH/N1948	<ul style="list-style-type: none"> Demonstration in Practical Lab 	Participant Handbook, Sewing Machine, Thread, Bobbin, Bobbin case, needle, Fabric, Buttons, Notebook, Pen	4:00 hrs.
			<p>Practical</p> <ul style="list-style-type: none"> Practice stitching to achieve desired speed and quality 	AMH/N1948	<ul style="list-style-type: none"> Practice Session 	Participant Handbook, Sewing Machine, Thread, Bobbin, Bobbin case, needle, Fabric, Notebook, Pen	10:00 hrs.

		Knowledge of basic Embroidery Stitches	<p>Theory</p> <p>1. Orient towards various hand embroidery stitches (Flat, loops and knotted)</p>	AMH/N1948	<ul style="list-style-type: none"> Power-point presentation Facilitator-led - discussion Audio-visual Clips 	Participant Handbook, Notepad, pen, duster, white board, marker, Computer, Projector, etc.	3:00 hrs.
			<p>Practical</p> <ul style="list-style-type: none"> Learn and practice running stitch, back stitch, stem stitch 	AMH/N1948	<ul style="list-style-type: none"> Facilitator-led – discussion Demonstration in the lab 	Embroidery Hoop, Fabric, Embroidery Needles, Embroidery Thread, Thimble, Tracing Paper, Notepad, Pen, Participant Handbook/ Facilitator Guide	3:00 hrs.
			<p>Practical</p> <ul style="list-style-type: none"> Learn and practice satin stitch, couching stitch, cross stitch 	AMH/N1948	<ul style="list-style-type: none"> Facilitator-led – discussion Demonstration in the lab 	Embroidery Hoop, Fabric, Embroidery Needles, Embroidery Thread, Thimble, Tracing Paper, Notepad, Pen, Participant Handbook/ Facilitator Guide	4:00 hrs.
			<p>Practical</p> <ul style="list-style-type: none"> Learn and practice herringbone stitch & chain stitch 	AMH/N1948	<ul style="list-style-type: none"> Facilitator-led – discussion Demonstration in the lab 	Embroidery Hoop, Fabric, Embroidery Needles, Embroidery Thread, Thimble, Tracing Paper, Notepad, Pen, Participant Handbook/ Facilitator Guide	4:00 hrs.
			<p>Practical</p> <ul style="list-style-type: none"> Learn and practice buttonhole stitch & blanket stitch 	AMH/N1948	<ul style="list-style-type: none"> Facilitator-led – discussion Demonstration in the lab 	Embroidery Hoop, Fabric, Embroidery Needles, Embroidery Thread, Thimble, Tracing Paper, Notepad, Pen, Participant Handbook/ Facilitator Guide	4:00 hrs.
			<p>Practical</p> <ul style="list-style-type: none"> Learn and practice fishbone stitch & feather stitch 	AMH/N1948	<ul style="list-style-type: none"> Facilitator-led – discussion Demonstration in the lab 	Embroidery Hoop, Fabric, Embroidery Needles, Embroidery Thread, Thimble, Tracing Paper, Notepad, Pen, Participant Handbook/ Facilitator Guide	4:00 hrs.
			<p>Practical</p> <ul style="list-style-type: none"> Learn and practice fly stitch & French knot stitch 	AMH/N1948	<ul style="list-style-type: none"> Facilitator-led – discussion Demonstration in the lab 	Embroidery Hoop, Fabric, Embroidery Needles, Embroidery Thread, Thimble, Tracing Paper, Notepad, Pen, Participant Handbook/ Facilitator Guide	4:00 hrs.
			<p>Practical</p> <ul style="list-style-type: none"> Learn and practice double knot & bullion knot 	AMH/N1948	<ul style="list-style-type: none"> Facilitator-led – discussion Demonstration in the lab 	Embroidery Hoop, Fabric, Embroidery Needles, Embroidery Thread, Thimble, Tracing Paper, Notepad, Pen, Participant Handbook/ Facilitator Guide	4:00 hrs.
			<p>Practical</p> <ul style="list-style-type: none"> Practice hand embroidery to achieve desired speed and quality 	AMH/N1948	<ul style="list-style-type: none"> Facilitator-led – discussion Demonstration in the lab 	Embroidery Hoop, Fabric, Embroidery Needles, Embroidery Thread, Thimble, Tracing Paper, Notepad, Pen, Participant Handbook/ Facilitator Guide	10:00 hrs.

		Establishing Learner's Understanding	<ul style="list-style-type: none"> Ensure learning confirmation 	Bridge Module	<ul style="list-style-type: none"> Facilitator led question-answer session Gauge the learner for their understanding & proficiency of the module Process based gauging to map learning curve 	Notepad, Fabric, Pencil, Pen, sewing machine, thread, needle, bobbin, bobbin case, Embroidery Hoop, Fabric, Embroidery Needles, Embroidery Thread, Thimble, Tracing Paper, Participant Handbook/ Facilitator Guide	-
4.	Inspections & Alterations for Fittings	Inspections & Alterations for fittings	<p>Theory</p> <ol style="list-style-type: none"> Orient towards the importance of garment fitting 	AMH/N1949	<ul style="list-style-type: none"> Power-point presentation Facilitator-led – discussion Audio-visual Clips 	Participant Handbook, Notepad, pen, duster, white board, marker, Computer, Projector, etc.	2:00 hrs.
			<p>Theory</p> <ol style="list-style-type: none"> Orient towards the procedure of carrying out fitting inspection 	AMH/N1949	<ul style="list-style-type: none"> Power-point presentation Facilitator-led – discussion Audio-visual Clips 	Participant Handbook, Notepad, pen, duster, white board, marker, Computer, Projector, etc.	2:00 hrs.
			<p>Theory</p> <ol style="list-style-type: none"> Familiarize with the common fitting errors and their solutions 	AMH/N1949	<ul style="list-style-type: none"> Power-point presentation Facilitator-led – discussion Audio-visual Clips 	Participant Handbook, Notepad, pen, duster, white board, marker, Computer, Projector, etc.	3:00 hrs.
			<p>Theory</p> <ol style="list-style-type: none"> Orient towards expected quality levels in garments 	AMH/N1949	<ul style="list-style-type: none"> Power-point presentation Facilitator-led – discussion Audio-visual Clips 	Participant Handbook, Notepad, pen, duster, white board, marker, Computer, Projector, etc.	3:00 hrs.
			<p>Practical</p> <ul style="list-style-type: none"> Learn and practice garment fitting procedure 	AMH/N1949	<ul style="list-style-type: none"> Demonstration using dress forms 	Note Pad, Pen, measuring tape, Fabric, Garment Pattern, Pins, etc.	6:00 hrs.
			<p>Practical</p> <ul style="list-style-type: none"> Learn and practice different methods of garment fitting 	AMH/N1949	<ul style="list-style-type: none"> Demonstration using dress forms 	Note Pad, Pen, measuring tape, Fabric, Garment Pattern, Pins, etc.	8:00 hrs.
			<p>Practical</p> <ul style="list-style-type: none"> Learn and practice bust alterations 	AMH/N1949	<ul style="list-style-type: none"> Demonstration using dress forms 	Note Pad, Pen, measuring tape, Fabric, Garment Pattern, Pins, etc.	8:00 hrs.
			<p>Practical</p> <ul style="list-style-type: none"> Identify and rectify fitting errors 	AMH/N1949	<ul style="list-style-type: none"> Demonstration using dress forms 	Note Pad, Pen, measuring tape, Fabric, Garment Pattern, Pins, etc.	8:00 hrs.
		Establishing Learner's Understanding	<ul style="list-style-type: none"> Ensure learning confirmation 	Bridge Module	<ul style="list-style-type: none"> Facilitator led question-answer session Gauge the learner for their understanding & proficiency of the module Process based gauging to map learning curve 	Notepad, Fabric, Garment Patterns, Pencil, Pen, sewing machine, thread, needle, bobbin, bobbin case, Participant Handbook/Facilitator Guide	-

5.	Maintain Health, Safety & Security in Tailoring Shop	Maintain Health, Safety and Security in Tailoring Shop	<p>Theory</p> <ol style="list-style-type: none"> 1. Health & Safety related instructions at the workplace 2. Identification and usage of Personal Protective Equipments 	AMH/N1950	<ul style="list-style-type: none"> • Facilitator-led - discussion 	Charts of good personal health practices, Chart for PPE note pad, pen, audio-visual clips	2:00 hr.
			<p>Theory</p> <ol style="list-style-type: none"> 1. Probable hazards at the workplace and handling them 	AMH/N1950	<ul style="list-style-type: none"> • Facilitator-led - discussion 	Note pad, pen, Computer, Projector audio-visual clips	2:00 hr.
			<p>Theory</p> <ol style="list-style-type: none"> 1. Probable machine/ equipment malfunctions 	AMH/N1950	<ul style="list-style-type: none"> • Facilitator-led - discussion 	Note pad, pen, Computer, Projector audio	1:00 hr.
			<p>Practical</p> <ul style="list-style-type: none"> • Wearing and taking off PPE 	AMH/N1950	<ul style="list-style-type: none"> • Practical Lab 	Note Pad, Pen, Various PPEs	2:00 hrs.
			<p>Practical</p> <ul style="list-style-type: none"> • Periodic walkthrough for hazard identification 	AMH/N1950	<ul style="list-style-type: none"> • Practical Lab 	Note Pad, Pen	2:00 hrs.
			<p>Practical</p> <ul style="list-style-type: none"> • Emergency Preparedness & Response • Safety Signs at workplace 	AMH/N1950	<ul style="list-style-type: none"> • Practical Lab 	Note Pad, Pen	6:00 hrs.
		Establishing Learner's Understanding	<ul style="list-style-type: none"> • Ensure learning confirmation 	AMH/N1950	<ul style="list-style-type: none"> • Facilitator led question-answer session • Gauge the learner for their understanding & proficiency of the module • Process based gauging to map learning curve 	Notepad, Fabric, Pencil, Pen, PPEs, Good health practices charts, Participant Handbook/ Facilitator Guide	-
6.	Comply with Industry, Regulatory and Organizational Requirements	Maintain Work Area, Tools and Machines	<p>Theory</p> <ol style="list-style-type: none"> 1. Importance of machine cleanliness and maintenance 	AMH/N0102	<ul style="list-style-type: none"> • Facilitator-led - discussion 	Handbook/Facilitator Guide	1:00 hr.
			<p>Theory</p> <ol style="list-style-type: none"> 1. Importance of Preventive & Running maintenance of machine & tools 	AMH/N0102	<ul style="list-style-type: none"> • Facilitator-led - discussion 	Handbook/Facilitator Guide	2:00 hrs.
			<p>Theory</p> <ol style="list-style-type: none"> 1. Minimization of waste 2. Safe waste disposal in the designated location 	AMH/N0102	<ul style="list-style-type: none"> • Facilitator-led - discussion 	Handbook/Facilitator Guide	1:00 hr.

			<p>Theory</p> <p>1. Work in a comfortable position with the correct posture and maintain personal health safety measures</p>	AMH/N0102	<ul style="list-style-type: none"> Facilitator-led - discussion 	Handbook/Facilitator Guide	1:00 hr.
			<p>Practical</p> <ul style="list-style-type: none"> Steps of cleaning the bobbin area Steps of cleaning the tension assembly Cleaning the feed dog assembly 	AMH/N0102	<ul style="list-style-type: none"> Practical Lab 	Note Pad, Pen, sewing machine	2:00 hrs.
			<p>Practical</p> <ul style="list-style-type: none"> Change needle guard Maintain machine after work is done 	AMH/N0102	<ul style="list-style-type: none"> Practical Lab 	Note Pad, Pen, sewing machine	2:00 hrs.
			<p>Practical</p> <ul style="list-style-type: none"> Maintain machine after work is done 	AMH/N0102	<ul style="list-style-type: none"> Practical Lab 	Note Pad, Pen, sewing machine	2:00 hrs.
			<p>Practical</p> <ul style="list-style-type: none"> Steps in lubricating Machine 	AMH/N0102	<ul style="list-style-type: none"> Practical Lab 	Note Pad, Pen, sewing machine, Oil	2:00 hrs.
			<p>Practical</p> <ul style="list-style-type: none"> Machine guards Sewing machine safety tips 	AMH/N0102	<ul style="list-style-type: none"> Practical Lab 	Note Pad, Pen, sewing machine	2:00 hrs.
		Establishing Learner's Understanding	<ul style="list-style-type: none"> Ensure learning confirmation 	AMH/N0104	<ul style="list-style-type: none"> Facilitator led question-answer session Gauge the learner for their understanding & proficiency of the module Process based gauging to map learning curve 	Note pad, Fabric, Pencil, Pen, Sewing Kit, Embroidery Kit, Participant Handbook/ Facilitator Guide	-
7.	Comply with Industry, Regulatory and Organizational Requirements	Comply with Industry and Organizational Requirements	<p>Theory</p> <p>1. General policies and regulations in the Apparel Industry</p> <p>2. Providing support to supervisors and team members</p>	AMH/N0104	<ul style="list-style-type: none"> Power-point presentation Facilitator-led – discussion Audio-visuals Clips 	Available Objects such as a book, pen, duster, white board, marker, Computer, Projector, etc.	3:00 hrs.
			<p>Theory</p> <p>1. Providing support to supervisors and team members</p>	AMH/N0104	<ul style="list-style-type: none"> Power-point presentation Facilitator-led – discussion Audio-visuals Clips 	Available Objects such as a book, pen, duster, white board, marker, Computer, Projector, etc.	2:00 hrs.
			<p>Practical</p> <ul style="list-style-type: none"> Identification and reporting of any policy deviation Working in a team 	AMH/N0104	<ul style="list-style-type: none"> Role Plays/team Work 	Note Pad, Pen	3:00 hrs.

			<p>Practical</p> <ul style="list-style-type: none"> • Role of APEC in Indian Garment Industry • Significance of compliance in Indian Garment Industry 	AMH/N0104	<ul style="list-style-type: none"> • Facilitator-led – discussion 	Note Pad, Pen	2:00 hrs.
		Establishing Learner's Understanding	<ul style="list-style-type: none"> • Ensure learning confirmation 	AMH/N0104	<ul style="list-style-type: none"> • Facilitator led question-answer session • Gauge the learner for their understanding & proficiency of the module • Process based gauging to map learning curve 	Note pad, Fabric, Pencil, Pen, Sewing Kit, Embroidery Kit, Participant Handbook/ Facilitator Guide	-
8.	Soft Skills	Professional Skills	<p>Theory</p> <ol style="list-style-type: none"> 1. Orientation towards managing job related stress effectively 2. Create an understanding about work ethics 	Bridge Module	<ul style="list-style-type: none"> • Power-point presentation • Facilitator-led - discussion • Audio-visuals Clips 	Presentation, Audio-visual clips, Participant Handbooks, Note Pad, Pen	1:00 hr.
			<p>Theory</p> <ol style="list-style-type: none"> 1. Awareness towards AIDS 2. Importance of health and hygiene 3. Awareness about ill effects of alcohol and tobacco. 	Bridge Module	<ul style="list-style-type: none"> • Power-point presentation • Facilitator-led - discussion • Audio-visuals Clips 	Presentation, Audio-visual clips, Participant Handbooks, Note Pad, Pen	1:00 hr.
			<p>Practical</p> <ul style="list-style-type: none"> • Creating a Resume 	Bridge Module	<ul style="list-style-type: none"> • Facilitator-led - discussion 	Note Pad, Pen	2:00 hrs.
		Establishing Learner's Understanding	<ul style="list-style-type: none"> • Ensure learning confirmation 	Bridge Module	<ul style="list-style-type: none"> • Facilitator led question-answer session • Gauge the learner for their understanding & proficiency of the module • Process based gauging to map learning curve 	Note pad, Fabric, Pencil, Pen, Sewing Kit, Embroidery Kit, Participant Handbook/ Facilitator Guide	-
9.	First Aid & CPR	First Aid & CPR	<p>Theory</p> <ol style="list-style-type: none"> 1. Create an understanding of CPR 2. First Aid & its application 	Bridge Module	<ul style="list-style-type: none"> • Power-point presentation • Facilitator-led – discussion • Audio-visual Clips 		1:00 hr.
			<p>Practical</p> <ul style="list-style-type: none"> • Use of First Aid • Performing CPR for an adult 	Bridge Module	<ul style="list-style-type: none"> • Practical Lab 	Note Pad, Pen	3:00 hrs.

		Establishing Learner's Understanding	<ul style="list-style-type: none"> Ensure learning confirmation 	Bridge Module	<ul style="list-style-type: none"> Facilitator led question-answer session Gauge the learner for their understanding & proficiency of the module Process based gauging to map learning curve 	Notepad, Fabric, Pencil, Pen, sewing machine, thread, needle, bobbin, bobbin case, Participant Handbook/ Facilitator Guide	-
10.	Employability and Entrepreneurship skills	Personal Strengths & Value Systems	<p>Theory</p> <ol style="list-style-type: none"> Awareness towards maintain health & hygiene Familiarise with life skills Self analysis & self motivation Stress & Anger Management Qualities of a successful Entrepreneur Conducting self in workplace Work ethics 	Bridge Module	<ul style="list-style-type: none"> Power-point presentation Facilitator-led – discussion Audio-visuals Clips 	Available Objects such as Participant Handbook /Facilitator's Guide, pen, duster, white board, marker, Computer, Projector, etc.	-
		Digital Literacy: A Recap	<p>Theory</p> <ol style="list-style-type: none"> Basic parts of computer & computer peripherals Basic computer terminology Basic computer application (MS office, Outlook, Internet) Basic features of using e-commerce 	Bridge Module	<ul style="list-style-type: none"> Power-point presentation Facilitator-led – discussion Audio-visuals Clips 	Available Objects such as Participant Handbook /Facilitator's Guide, pen, duster, white board, marker, Computer, Projector, etc.	-
		Money Matters	<p>Theory</p> <ol style="list-style-type: none"> Opening and operating a bank account Importance and methods of savings Investment options Insurance products Cost of Operations Types of Fund Transfer 	Bridge Module	<ul style="list-style-type: none"> Power-point presentation Facilitator-led – discussion Audio-visuals Clips 	Available Objects such as Participant Handbook /Facilitator's Guide, pen, duster, white board, marker, Computer, Projector, etc.	-
		Preparing for Employment and Self Employment	<p>Theory</p> <ol style="list-style-type: none"> Discuss the steps to prepare for an interview Discuss the steps to create an effective Resume Discuss the most frequently asked interview questions Discuss how to answer the most frequently asked interview questions Discuss basic workplace terminology 	Bridge Module	<ul style="list-style-type: none"> Power-point presentation Facilitator-led – discussion Audio-visuals Clips 	Available Objects such as Participant Handbook /Facilitator's Guide, pen, duster, white board, marker, Computer, Projector, etc.	-

		Understanding Entrepreneurship	<p>Theory</p> <ol style="list-style-type: none"> 1. Discuss the concept and characteristics of entrepreneurship 2. Describe the different types of enterprises 3. Establishing effective leadership 4. Team Work 5. Importance of effective communication 6. Discuss about Negotiation Skills and Conflict Resolution 7. Entrepreneurship ecosystem in India 	Bridge Module	<ul style="list-style-type: none"> • Power-point presentation • Facilitator-led – discussion • Audio-visuals Clips 	Available Objects such as Participant Handbook /Facilitator’s Guide, pen, duster, white board, marker, Computer, Projector, etc.	-
		Preparing to be an Entrepreneur	<p>Theory</p> <ol style="list-style-type: none"> 1. Basic Marketing Skills 2. Recall basic business terminology 3. CRM and its importance 4. Setting and achieving goals 5. Making a Business Plan 6. Carrying out a market research 7. CRM and its importance 8. Business & Financial Planning Process 9. Managing a enterprise 	Bridge Module	<ul style="list-style-type: none"> • Power-point presentation • Facilitator-led – discussion • Audio-visuals Clips 	Available Objects such as Participant Handbook /Facilitator’s Guide, pen, duster, white board, marker, Computer, Projector, etc.	-
		Establishing Learner’s Understanding	<ul style="list-style-type: none"> • Ensure learning confirmation 	Bridge Module	<ul style="list-style-type: none"> • Facilitator led question-answer session • Gauge the learner for their understanding & proficiency of the module • Process based gauging to map learning curve 	Notepad, Fabric, Pencil, Pen, sewing machine, thread, needle, bobbin, bobbin case, Participant Handbook/ Facilitator Guide	-

Annexure II

Assessment Criteria

CRITERIA FOR ASSESSMENT OF TRAINEES

Assessment Criteria for Hand Embroiderer	
Job Role	Self Employed Tailor
Qualification Pack	AMH/Q1947
Sector Skill Council	APPAREL, MADE-UP'S AND HOME FURNISHING
Sr. No.	Guidelines for Assessment
1	Criteria for assessment for each Qualification Pack will be created by the Sector Skill Council. Each Performance Criteria (PC) will be assigned mark
2	Each NOS will assessed both for theoretical knowledge and practical
3	The assessment will be based on knowledge bank of questions created by the SSC.
4	Individual assessment agencies will create unique question papers for theory and skill practical part for each candidate at each examination/training center
5	To pass the Qualification Pack, every trainee should score a minimum of 70% in every NOS
6	In case of successfully passing only certain number of NOS's, the trainee is eligible to take subsequent assessment on the balance NOS's to pass the Qualification Pack.

NOS	Performance Criteria	Total Marks	Out Of	Marks Allocation		
				Theory	Skills Practical	Viva
1. AMH/N1947 (Drafting and cutting the fabric)	PC1. Take body measurement of the customer or the product	85	9	3	5	1
	PC2. Select the appropriate tools and materials for drafting		8	2	5	1
	PC3. Mark the measurements of a garment on a piece of paper with the help of the tools and make the standard patterns for reference		10	3	7	0
	PC4. Cut the paper pattern as per the measurement		12	2	10	0
	PC5. Place the cut components of paper for cutting the cloth		7	1	5	1
	PC6. Select the appropriate tools and materials for cutting		10	2	7	1
	PC7. Measure the length and width of the material/fabric before starting to cut		8	1	7	0
	PC8. Ensure there are no defects on the material		4	1	3	0

	PC9. Lay the fabric on the table in accordance with fabric grain line, designs, checks or plaids, etc.		4	0	3	1
	PC10. Cut the various garment components with precision		6	0	5	1
	PC11. Avoid fabric/material wastage while cutting		3	0	3	0
	PC12. Organise cut components in a suitable bundle tied together		4	1	3	0
			85	16	63	6
2. AMH/N1948 (Carry out the process of sewing for dress materials and common household items of textiles)	PC1. Set machines according to manufacturers' instructions and sewing requirements	110	18	7	10	1
	PC2. Set machine controls for the materials being stitched		17	5	10	2
	PC3. Perform a test run to ensure machine is operating correctly		21	5	15	1
	PC4. Join cut components by stitching		22	5	14	3
	PC5. Carry out hand sewing (kaj making, button fixing, hemming, basic embroidery etc.)		20	6	12	2
	PC6. Make a final cost sheet		12	7	4	1
			Total	110	35	65
3. AMH/N1949 (Carry out inspections and alterations to adjust corrections for fittings)	PC1. Check fitting of the dress materials onto the customers	50	17	3	13	1
	PC2. Record required alteration needs and instructions on tags or labels and attach them to garments		15	9	5	1
	PC3. Carry out alterations as per records		18	6	12	0
			50	18	30	2
4. AMH/N1950 (Maintain health, safety and security in the tailoring shop)	PC1. Keep vigilance for potential risks and threats associated with shop and its equipments like fire, theft, etc.	30	6	2	3	1

	PC2. Handle tools and equipments like sewing machines, scissors, shears, etc. safely and securely		5	2	2	1
	PC3. Keep alert in the shop and during work processes to avoid potential risks and threats		7	3	3	1
	PC4. Install basic safety signage in the shop for customer knowledge as well		6	2	3	1
	PC5. Undertake first-aid, fire-fighting and emergency response training		6	2	3	1
			30	11	14	5
5. AMH/N0102 (Maintain workarea, tools and machines)	PC1. Handle materials, machinery, equipment and tools safely and correctly	40	3	0	2	1
	PC2. Use correct lifting and handling procedures		3	1	2	0
	PC3. Use materials to minimize waste		3	1	1	1
	PC4. Maintain a clean and hazard free working area		3	0	2	1
	PC5. Maintain tools and equipments		2	0	2	0
	PC6. Carry out running maintenance within agreed schedules		4	1	2	1
	PC7. Carry out maintenance and/or cleaning within one's responsibility		2	0	2	0
	PC8. Report unsafe equipment and other dangerous occurrences		3	2	1	0
	PC9. Ensure that the correct machine guards are in place		3	0	2	1
	PC10. Work in a comfortable position with the correct posture		2	0	2	0
	PC11. Use cleaning equipment and methods appropriate for the work to be carried out		4	1	2	1
	PC12. Dispose of waste safely in the designated location		2	0	2	0

	tasks when the instructions you have are unclear					
	PC6. Use the correct tools and materials		5	1	3	1
	PC7. Select the correct component parts/fabric/material for embroidery		7	1	4	2
	PC8. Check that the materials to be used are free from faults		5	1	3	1
	PC9. Ensure the materials used meet the specification matching a. Embroidery Artwork b. Design sample of the embroidered product		8	3	3	2
	PC10. Report faults in the materials		4	1	2	1
	PC11. Conform to company quality standards		5	1	3	1
	PC12. Report any damaged work to the responsible person		5	1	3	1
	PC13. Make Satin, chain, button hole stitches & different types of edges (hem stitch, scallops, lace & rolled hem)		4	1	2	1
	PC14. Make Long & short, shade work, satin & French knot stitches		5	1	3	1
	PC15. Carry out Applique work as per design details		5	1	3	1
	PC16. Use & combine different hand embroidery techniques to create decorative designs such as:§ Cross Stitch § Tapestry Stitch § Shadow work § Mirror work § English Smocking § Cut work § Sindhi Work		5	1	3	1
	PC17. Ensure the embroidered design conforms to the artwork specifications		5	1	3	1
	PC18. Inspect embroidered products against specifications		8	2	3	3
	PC19. Perform all embroidery operations with precision & accuracy		4	1	2	1
		Total	100	26	50	24
3. AMH/N1003 (Contribute to achieve quality in embroidery work)	PC1. Identify and use materials required based on the specifications	90	8	4	2	2
	PC2. Take the necessary action when materials do not conform to quality standards		5	3	1	1
	PC3. Report and replace identified faulty materials and component parts which do not meet		6	1	4	1

	PC13. Store cleaning equipment safely after use		2	0	2	0	
	PC14. Carry out cleaning according to schedules and limits of responsibility		4	1	2	1	
			40	7	26	7	
6. AMH/N0104 (Comply with industry, regulatory and organizational requirements)	PC1. Carry out work functions in accordance with legislation and regulations, organizational guidelines and procedures	35	7	4	2	1	
	PC2. Seek and obtain clarifications on policies and procedures, from your supervisor or other authorized personnel		5	3	1	1	
	PC3. Apply and follow these policies and procedures within your work practices		7	3	3	1	
	PC4. Provide support to your supervisor and team members in enforcing these considerations		8	3	4	1	
	PC5. Identify and report any possible deviation to these requirements		8	5	2	1	
	Total Marks		350	35	18	12	5
	Total Marks		350	350	105	210	35

Do

- Explain each Guideline for Assessment in detail
- Explain the score that each trainee needs to obtain
- Recapitulate each NOS one-by-one and take participants through the allocation of marks for Theory and Skills Practical.
- Explain the Allocation of Marks. Explain that they will be assessed on Theory and Skills Practical.





Skill India
विद्यया ऽमृतमश्नुते - अज्ञानं मृतमश्नुते



**APPAREL MADE-UPS HOME FURNISHING
SECTOR SKILL COUNCIL**

Apparel Made-ups & Home Furnishing Sector Skill Council
Indian Buildings Congress, 1st Floor, Sector-6, R K Puram
Kama Koti marg, New Delhi - 110022
E-mail : info@sscamh.com
Website : www.sscamh.com

Price: ₹